

# **Using semantic profiling to characterize pedagogical practices and student learning: A case study in two introductory physics courses**

Christiana Honjiswa Conana

A thesis submitted to the Faculty of Science at the University of the Western Cape in fulfillment of the requirements for the degree of Doctor of Philosophy



October 2015

## Abstract

Framed by the South African imperative of widening epistemological access to undergraduate science studies, this research takes the form of a case study to investigate the educational affordances of an extended introductory physics course. Using theoretical tools from Legitimation Code Theory (LCT) (Maton, 2014a) – in particular, semantic gravity and semantic density – the study characterizes the pedagogical practices and student learning in this Extended course, in relation to a Mainstream course in the same Physics Department.

Data was collected through classroom observations, observations of student groups working on Mechanics physics tasks, and interviews with students. Two external languages of description were developed in order to translate between the LCT concepts of semantic gravity and semantic density and the empirical data from the physics context. The first language of description was used to characterize the semantic shifts in pedagogical practices, using a Concrete-Linking-Abstract continuum. The second language of description drew on physics education research on representations (Knight, 2007; Van Heuvelen, 1991a) tasks. Semantic profiles (Maton, 2013) were then constructed to show the semantic shifts in the pedagogical practices and in lecturers' and students' approaches to physics tasks.

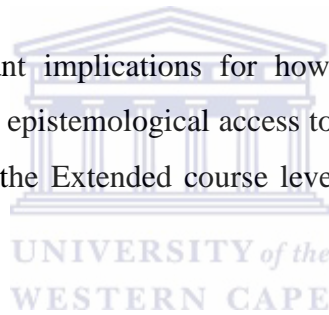
The study has shown that the extra curriculum time enabled different *pedagogical practices*. The Extended course showed a steady progression in pacing, initially with a less compressed semantic profile, while the Mainstream course showed a consistent compression. The Extended course showed a greater prevalence of the Linking level, with more time spent at the Concrete level and greater semantic flow. The courses also exhibited different communicative approaches, with students in the Extended course more engaged in making the semantic shifts together with the lecturer. The Extended course used more real-life illustrations as a starting point, whereas the Mainstream course tended to use verbal problem statements.

Looking particularly at how *problem tasks* were dealt with, the study suggested that the lecturers' pedagogical practices in dealing with physics tasks influenced the way

in which the students tackled these tasks. The semantic profiles showed a more rapid shift up the semantic continuum in the Mainstream pedagogy and student work, while in the Extended pedagogy and student work, the semantic profiles indicated that more time was spent initially unpacking the concrete problem situation and explicitly shifting up and down the semantic continuum.

In terms of methodological contribution, this study has demonstrated the usefulness of LCT tools for characterizing pedagogical practices and student learning in a physics context. Furthermore, the study has linked LCT to physics education literature and to research on epistemological access and academic literacies in a novel way. It has modified Maton's form of semantic profiling, through introducing the following: a more detailed time scale, gradations of semantic strength on the semantic continuum, and coding for interactive engagement in pedagogical practices.

The study thus has important implications for how curriculum and pedagogical practices might better support epistemological access to disciplinary knowledge in the field of physics, not only at the Extended course level but for introductory physics courses more generally.



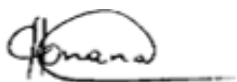
## Declaration

I declare that “Using semantic profiling to characterize pedagogical practices and student learning: A case study in two introductory physics courses” is my own work, that it has not been submitted for any degree or examination in any other university, and that all the sources I have used or quoted have been indicated and acknowledged by complete references.

Christiana Honjiswa Conana

Date: 16 March 2016

Signed:



## Acknowledgements

I would not have been able to complete this thesis without Almighty God and His everlasting grace. I therefore extend my sincere gratitude to Him.

This thesis is the product of the support of a number of people. These people have groomed me, developed me and engraved in me a passion for research. I treasure the contribution of these individuals, which has helped me to shape and reshape this thesis.

Even though the credit for a thesis is attached solely to one person, I could not have completed such a challenging scholarly venture on my own. This thesis would never have come into this form, if it had not been for my supervisors – Prof Delia Marshall, Prof Jenni Case and Prof Lorna Holtman. You believed in my ideas from the beginning and you were confident that I could execute them. You offered deep insights and challenged me more than anyone else. Thank you most of all for believing in me. Delia, the encouragement and tireless support you have given me throughout this whole venture went beyond limits – your door was always open and you were always considerate and helpful when things were going wrong on my side. Jenni and Lorna, I greatly appreciate the valuable and significant intellectual contributions, guidance, and useful recommendations that you have given me, as well as your steadfast commitment and support; without you, none of these pages would have been written.

Equally, I also hold dear in my heart Prof Cedric Linder, who generously accepted my request to be a critical reader for this thesis. You shared your passion for physics education, challenged my thinking, and helped me to communicate my ideas clearly. You managed the seemingly impossible task of providing both critical guidance and personal kindness.

To the Sasol Inzalo Fellowship and CREE, I consider myself exceptionally fortunate to be counted as a member of these outstanding research groups. I am indescribably

thankful for the input and suggestions my research group members have offered. It is the spirit of encouraging one another in these research groups that kept me going.

Thank you to all my dear friends for your help. You were my pillar of strength, supporting and encouraging me in good and bad times. Without you I would not have made it.

Thank you to the Physics Department at the University of the Western Cape, which made it possible for me to take time off so that I could concentrate on this PhD study. My deepest appreciation goes to all the students in the department who were willing to be participants in this study. These students gladly welcomed me into their space so that I could study how they experienced physics. Also, I thank the lecturers who allowed me to observe their lectures. I cannot name them for ethical reasons but I am deeply indebted to these individuals. Also, I thank all my colleagues in the Physics Department for their kind words of encouragement and support, and I would like to thank the ECP staff for accepting additional responsibilities while I was on leave.

To my family: I am forever grateful to my grandparents and my parents Vusumzi and Mputseng Conana: without them, I would not be where I am today, and I would not be who I am today. Your constant support of my educational curiosity is really the true meaning of everlasting love. I also thank my sister, my sister in law, my brothers, my nieces and nephews for their endless love and support, and for their tolerance during the taxing times of my research. Last, but not least, I especially thank my beloved daughter – Okuhle – for her understanding and for allowing me to neglect my maternal duties at times. Thanks, my baby, had it not been for your patience, I would not have been able to complete this thesis.

I would like to acknowledge my appreciation for the PhD funding from a Sasol Inzalo Fellowship grant, and the excellent proofreading of my thesis by Ms. Regine Lord.

# Table of Contents

|  |             |
|--|-------------|
| <b>Abstract</b> .....  | <b>i</b>    |
| <b>Declaration</b> .....   | <b>iii</b>  |
| <b>Acknowledgements</b> .....  | <b>iv</b>   |
| <b>Table of Contents</b> .....   | <b>vi</b>   |
| <b>List of Tables</b> .....  | <b>xii</b>  |
| <b>List of Figures</b> .....   | <b>xiii</b> |
| <b>List of Acronyms</b> .....  | <b>xv</b>   |
| <b>Chapter 1: Introduction</b> .....   | <b>1</b>    |
| 1.1 Access and success in university science education .....                                 | 1           |
| 1.2 Epistemological access and academic literacies .....                                     | 2           |
| 1.3 Context of the study .....   | 5           |
| 1.4 Introducing the theoretical framework.....   | 8           |
| 1.5 Research questions.....  | 9           |
| 1.6 Overview of the thesis structure: Chapter outline.....                                   | 9           |
| <b>Chapter 2: Review of Physics Education Research Literature</b> .....                      | <b>11</b>   |
| 2.1 Introduction.....  | 11          |
| 2.2 Science learning and conceptual change.....  | 11          |
| 2.3 The social context of learning.....  | 14          |
| 2.4 Research on university science teaching.....   | 16          |
| 2.5 Representations in the teaching and learning of physics .....                            | 18          |
| 2.5.1 Students' difficulties with representations.....                                       | 20          |
| 2.5.2 Representations in tackling physics problems .....                                     | 23          |
| 2.6 Concluding remarks .....   | 25          |
| <b>Chapter 3: Theoretical Framework</b> .....  | <b>26</b>   |
| 3.1 Introduction.....  | 26          |
| 3.2 Knowledge structures.....  | 27          |
| 3.3 The 'pedagogic device': Fields of production, recontextualisation and reproduction ..... | 29          |

|  |   |           |
|--|---|-----------|
| 3.4  | Classification and framing .....  | 30        |
| 3.5  | Cumulative and segmented learning.....  | 31        |
| 3.6  | Legitimation Code Theory .....  | 31        |
| 3.6.1  | Semantics in LCT .....  | 32        |
| 3.6.2  | Semantic gravity .....  | 33        |
| 3.6.3  | Semantic density .....  | 34        |
| 3.6.4  | Semantic profiles .....   | 35        |
| 3.7  | Conclusion .....  | 37        |
| <b>Chapter 4: Research Methods and Design .....</b>            |   | <b>39</b> |
| 4.1  | Introduction.....   | 39        |
| 4.2  | Case study methodology .....  | 39        |
| 4.3  | A case study of two undergraduate physics courses.....  | 40        |
| 4.4  | Research methods .....  | 41        |
| 4.5  | Data gathering.....   | 43        |
| 4.5.1  | Observation of pedagogical practices .....  | 43        |
| 4.5.2  | Observation of student groups tackling a Newton 2 <sup>nd</sup> Law physics task .....                                    | 45        |
| 4.6  | Data analysis .....   | 46        |
| 4.6.1  | Data reduction.....   | 46        |
| 4.6.2  | Developing an external language of description (LoD) to carry out the semantic gravity and semantic density analysis..... | 47        |
| 4.6.3  | Creating a semantic profile in terms of semantic gravity and semantic density .....                                       | 55        |
| 4.7  | Validity and reliability .....  | 56        |
| 4.8  | Ethical issues.....   | 59        |
| 4.9  | Conclusion .....  | 59        |
| <b>Chapter 5: The Introductory Physics Context at UWC.....</b> |   | <b>60</b> |
| 5.1  | Introduction.....   | 60        |
| 5.2  | The curriculum structure.....   | 60        |
| 5.3  | The classroom setting .....   | 63        |
| 5.4  | Use of course materials.....  | 64        |
| 5.5  | Concluding remarks .....  | 65        |



**Chapter 6: Pedagogical practices: The semantic profiles of Mainstream and Extended Courses – Lecture Sequence 1..... 67**

|       |  |    |
|-------|--|----|
| 6.1   | Introduction.....  | 67 |
| 6.2   | Detailed analysis of lecture sequences from the Mainstream and Extended courses..... | 68 |
| 6.2.1 | How to interpret the data tables and semantic profiles below .....                   | 68 |
| 6.2.2 | Mainstream course: Lecture sequence 1 .....  | 69 |
| 6.2.3 | Extended course: Lecture sequence 1 .....  | 80 |
| 6.3   | Summary of analysis of semantic profiles of pedagogical practice.....                | 90 |
| 6.4   | Conclusion to Chapter 6.....   | 93 |

**Chapter 7: Pedagogical practices: The semantic profiles of Mainstream and Extended courses – lecture sequence 2 ..... 94**

|       |  |     |
|-------|--|-----|
| 7.1   | Introduction.....  | 94  |
| 7.2   | Detailed analysis of lecture sequences from Mainstream and Extended courses .....                        | 94  |
| 7.2.1 | Mainstream course: Lecture sequence 2 .....  | 95  |
| 7.2.2 | Extended course: Lecture sequence 2 .....  | 99  |
| 7.3   | Summary of analysis of semantic profiles of the Mainstream and Extended courses lecture sequence 2 ..... | 105 |
| 7.4   | Conclusion to Chapter 7.....   | 111 |

**Chapter 8: How Physics Problems are dealt with in Class..... 112**

|       |   |     |
|-------|---|-----|
| 8.1   | Introduction.....   | 112 |
| 8.2   | Detailed analysis of physics tasks involving Newton’s 2 <sup>nd</sup> Law from Mainstream and Extended course lectures..... | 113 |
| 8.2.1 | How to interpret the data tables and semantic profiles below .....  | 113 |
| 8.2.2 | Mainstream course lecture sequence 3 – Newton’s 2 <sup>nd</sup> Law physics task .....                                      | 115 |
| 8.2.3 | Extended course lecture sequence 3 – Newton’s 2 <sup>nd</sup> Law physics task .....  | 122 |
| 8.3   | Summary of analysis of semantic profiles of pedagogical practice.....   | 135 |
| 8.3.1 | The semantic profiles of pedagogical practices at a glance.....   | 135 |
| 8.3.2 | The semantic profiles in terms of ‘communicative approaches’ used in the lectures .....                                     | 136 |

|   |            |
|---|------------|
| 8.3.3. Similarities and differences in the use of representations in tackling a physics task .....  | 138        |
| 8.4 Conclusion to Chapter 8.....  | 144        |
| <b>Chapter 9: How the Pedagogy Influences Students' Work .....</b>  | <b>147</b> |
| 9.1 Introduction.....   | 147        |
| 9.2 Analyses of students tackling Newton's 2 <sup>nd</sup> Law physics tasks in the Mainstream and the Extended courses.....  | 147        |
| 9.3 The Mainstream course students (Group 1) tackling a physics task.....   | 150        |
| 9.3.1 Overview of Mainstream course Group 1 tackling a Newton's 2 <sup>nd</sup> Law physics task.....   | 153        |
| 9.3.2 Overview of Mainstream course Group 2 tackling a Newton's 2 <sup>nd</sup> Law physics task.....   | 155        |
| 9.4 The Extended course students tackling a physics task.....   | 156        |
| 9.4.1 Overview of Extended course Group 1 tackling a Newton's 2 <sup>nd</sup> Law physics task .....  | 159        |
| 9.4.2 Overview of Extended course Group 2 tackling a Newton's 2 <sup>nd</sup> Law physics task .....  | 162        |
| 9.5 Summary of analysis of the semantic profiles for the student groups tackling a physics task in the Mainstream and the Extended courses .....  | 163        |
| 9.5.1 How the problem is introduced and set up (read and unpack).....   | 165        |
| 9.5.2 From the verbal representation to a FBD (model the situation) .....   | 167        |
| 9.5.3 Constructing the physical representation – the FBD (visualise).....   | 168        |
| 9.5.4 Mathematical representation (set up mathematical form of Newton's 2 <sup>nd</sup> Law and solve).....   | 172        |
| 9.5.5 Assessing and evaluating the solution .....   | 175        |
| 9.6 Conclusion to Chapter 9.....  | 175        |
| <b>Chapter 10: Discussion .....</b>   | <b>178</b> |
| 10.1 Introduction.....  | 178        |
| 10.2 Research question 1: What is the nature of the Mainstream and Extended courses' pedagogical practices in terms of their semantic profiles (i.e. semantic gravity and semantic density)?..... | 179        |

|   |  |            |
|---|--|------------|
| 10.3  | Research question 2: What is the correspondence between the pedagogical practices and the ways in which the students approach physics tasks in the Mainstream and Extended Physics courses?..... | 183        |
| 10.4  | Educational affordances of the Extended Physics course’s pedagogical practices .....   | 186        |
| 10.4.1  | Linking to familiar concepts .....   | 187        |
| 10.4.2  | Use of examples .....  | 189        |
| 10.4.3  | Making the tacit explicit .....  | 190        |
| 10.4.4  | The explicit use of representations .....  | 190        |
| 10.4.5  | Semantic flow .....  | 191        |
| 10.4.6  | Explicitly building on prior knowledge .....   | 192        |
| 10.4.7  | Use of teaching and learning materials .....   | 192        |
| 10.4.8  | The role of interactive engagement.....  | 193        |
| 10.4.9  | Summary of differences in introductory physics pedagogical practice .....  | 194        |
| 10.5  | Methodological contributions of the study .....  | 194        |
| 10.6  | Conclusion .....   | 197        |
| <b>Chapter 11: Conclusion.....</b>  |  | <b>198</b> |
| 11.1  | Introduction.....  | 198        |
| 11.2  | Implications for extended programmes .....   | 199        |
| 11.3  | Implications for future research .....   | 201        |
| <b>References .....</b>   |  | <b>204</b> |
| <b>Appendices.....</b>  |  | <b>220</b> |
| <b>1. Curriculum Documents .....</b>                                      |  | <b>220</b> |
|   | Appendix 1A – Mainstream information sheet.....  | 220        |
|   | Appendix 1B - Extended course reader .....   | 223        |
|   | Appendix 1C – Extended course Concept map .....  | 230        |
| <b>2. Summary data of pedagogical practices - lecture sequence 2.....</b> |  | <b>231</b> |
|   | Appendix 2A – Mainstream course .....  | 231        |
|   | Appendix 2B – Extended course.....   | 237        |
| <b>3. Interview questions with students tackling a physics task.....</b>  |  | <b>249</b> |
|   | Appendix 3A – Mainstream course physics task interview questions.....  | 249        |

|   |            |
|---|------------|
| Appendix 3B – Extended course physics task interview questions .....                                    | 250        |
| <b>4. Summary Data Tables .....</b>   | <b>252</b> |
| Appendix 4 – Students’ use of representations when tackling a physics task<br>(Mainstream Group 1)..... | 252        |
| <b>5. Ethics Documents .....</b>  | <b>262</b> |
| Appendix 5: Students’ Participation Pre-request.....  | 262        |



## List of Tables

|             |   |     |
|-------------|---|-----|
| Table 4.1   | Overview of research questions, methods of data gathering and analytical tools.....   | 42  |
| Table 4.2:  | Summary of the data relating to classroom observations in both courses .....  | 44  |
| Table 4.3:  | External LoD for various levels of Semantics .....  | 48  |
| Table 4.4.  | External LoD for shifts in semantic density (SD) .....  | 50  |
| Table 4.5:  | Framework of representations to be used in tackling a mechanics problem (based on Knight, 2007 and Van Heuvelen, 1991a) ..... | 52  |
| Table 5.1:  | Selection and sequencing of topics in the Mainstream and Extended courses .....   | 61  |
| Table 6.1:  | Summary data for Mainstream lecture sequence 1 (Topic: Work-Energy) .....   | 70  |
| Table 6.2:  | Summary data for Extended lecture sequence 1 (Topic: Position & Displacement).....  | 81  |
| Table 8.1:  | Mainstream lecture sequence 3: Tackling a Newton's 2 <sup>nd</sup> Law physics task .....                                     | 116 |
| Table 8.2:  | Extended lecture sequence 3: Tackling a Newton's 2 <sup>nd</sup> Law physics task .....                                       | 122 |
| Table 10.1: | Key aspects of the semantic profiles of the Extended course in relation to those of the Mainstream course.....                | 181 |
| Table 10.2: | The time spent by the lecturers and the students while tackling a Newton's 2 <sup>nd</sup> Law physics task .....             | 184 |

## List of Figures

|             |  |     |
|-------------|--|-----|
| Figure 3.1: | Semantic gravity in relation to the structuring of knowledge (Maton, 2009).....                                    | 33  |
| Figure 3.2: | Illustrative semantic profiles and semantic ranges (Maton, 2013: p.15) .....                                       | 35  |
| Figure 4.1: | Semantic gravity and semantic density in relation to multiple representations in physics problem tasks .....       | 54  |
| Figure 6.1: | The semantic profile for the Mainstream lecture sequence 1 (Topic: Work-Energy).....                               | 78  |
| Figure 6.2: | The semantic profile for the Extended lecture sequence 1 (Topic: Position & Displacement) .....                    | 88  |
| Figure 6.3: | Semantic profiles for the pedagogical practices in the Mainstream and the Extended lecture sequence 1 .....        | 90  |
| Figure 7.1: | The semantic profile for the Mainstream lecture sequence 2 (Topic: Work-Energy).....                               | 96  |
| Figure 7.2: | The semantic profile for the Extended lecture sequence 2 (Topic: Work-Energy).....                                 | 100 |
| Figure 7.3: | Semantic profiles for the pedagogical practices in the Mainstream and the Extended lecture sequence 2 .....        | 105 |
| Figure 8.1: | The semantic profile for Mainstream lecture sequence 3: Tackling a Newton's 2 <sup>nd</sup> Law physics task ..... | 120 |
| Figure 8.2: | The semantic profile for Extended lecture sequence 3: Tackling a Newton's 2 <sup>nd</sup> Law physics task .....   | 132 |
| Figure 8.3: | Semantic profiles for the pedagogical practices in the Mainstream and the Extended lecture sequence 3 .....        | 134 |
| Figure 9.1: | The semantic profile for Mainstream Group 1 tackling a Newton's 2 <sup>nd</sup> Law physics task .....             | 151 |
| Figure 9.2: | The semantic profile for Mainstream Group 2 tackling a Newton's 2 <sup>nd</sup> Law physics task .....             | 153 |
| Figure 9.3: | The semantic profile for Extended Group 1 tackling a Newton's 2 <sup>nd</sup> Law physics task .....               | 157 |
| Figure 9.4: | The semantic profile for Extended Group 2 tackling a Newton's 2 <sup>nd</sup> Law physics task .....               | 160 |

Figure 9.5: Semantic profiles for the student groups tackling a physics task in the Mainstream and the Extended courses .....163

Figure 10.1: A summary of the semantic profiles for the lecture sequences in the Mainstream and Extended courses, presented in Chapters 6 to 8 .....179

Figure 10.2: A summary of the semantic profiles for the Mainstream and Extended lecturers and students while tackling a physics task .....183



## List of Acronyms

|          |   |
|----------|---|
| CHE      | Council on Higher Education   |
| CHE-SAIP | Council on Higher Education – South African Institute of Physics        |
| CREE     | Centre for Research in Engineering Education                            |
| DoE      | Department of Education   |
| ECP      | Extended Curriculum Programme   |
| FBD      | Free Body Diagram   |
| IE       | Interactive engagement  |
| IOP      | Institute of Physics  |
| ISLE     | Investigative Science Learning Environment                              |
| LCT      | Legitimation Code Theory  |
| LoD      | Language of Description   |
| OHP      | Overhead projector  |
| OECD     | Organisation for Economic Co-operation and Development                  |
| PER      | Physics education research  |
| QAA      | Quality Assurance Agency for Higher Education                           |
| SAIP     | South African Institute of Physics                                      |
| SCALE-UP | Student-Centered Active Learning Environment for Undergraduate Programs |
| SD       | Semantic density  |
| SG       | Semantic gravity  |
| STEM     | Science, Technology, Engineering and Mathematics                        |
| UWC      | University of the Western Cape  |



# Chapter 1:

## Introduction

### 1.1 Access and success in university science education

Internationally, there have been concerns since the early 1990s about declining enrolments and student interest in pursuing physics studies at university level, as well as concerns about student attrition and the quality of undergraduate physics education (American Association of Physics Teachers [AAPT], 1996; Institute of Physics [IOP], 2011; Sharma, Mills, Mendez & Pollard, 2005). Furthermore, Johannsen, Rump and Linder (2013) note that attrition rates in science and technology disciplines are among the highest in tertiary education in European countries, as well as in Organisation for Economic Co-operation and Development (OECD) countries. These concerns about student participation and attrition are often linked to arguments about the importance of physics-based activities in contributing to economic growth (see, for example, IOP, 2012) but also to the broader benefits of a scientifically informed citizenry (South African Institute of Physics [SAIP], 2004).

In South Africa, studies on student throughput and retention in higher education (Council on Higher Education [CHE], 2013; Scott, Yeld & Hendry, 2007) show a high attrition rate at first year level within science and technology fields, as well as a low overall completion rate and a very small group who complete their degrees within the regulation time. With regard to the BSc degree, the CHE study (2013) indicated that only 23% of students actually completed their degrees. Within the physical science fields, specifically, only 21% of students complete their degrees in the minimum time (three years). A recent review of undergraduate physics education in South Africa (Council on Higher Education – South African Institute of Physics [CHE-SAIP], 2013) highlights concerns about the under-preparedness of students entering first year physics and the level of graduate competence when completing their first degree. The report concludes that more research-based initiatives are required to support student success by developing ‘more effective ways of teaching under-prepared students’ (CHE-SAIP, 2013: p. 34). In conceptualizing such initiatives aimed at supporting student success in higher education in South Africa, the concept

of ‘epistemological access’ (Morrow, 1993) has been key. This is discussed further in the next section.

## 1.2 Epistemological access and academic literacies

In considering student access and success in higher education, Morrow (1993) introduces the concept of ‘epistemological access’. He distinguishes ‘epistemological access’ from ‘formal access’: formal access entails admitting students to the university and allowing them to study there, while epistemological access entails accessing disciplinary knowledge and norms. As Boughey (2005) notes, epistemological access involves ‘bridging the gaps between the respective worlds students and lecturers draw on... [and] making overt the “rules and conventions” that determine what can count as knowledge’ (p. 240). Epistemological access is discipline-specific, requiring engagement with both the content knowledge and the ways of knowledge development in that particular discipline (Boughey, 2005), in addition to dealing with students’ identities (Boughey, 2008; McKenna, 2004).

The links between epistemological access and academic literacy are evident in the literature (see, for example, Boughey, 2010a; McKenna, 2010), where academic literacy is conceived as ‘a compound of linguistic, conceptual and epistemological rules and norms of the academe’ (Ballard & Clanchy, 1988: p. 8). From this perspective, academic literacy is linked not merely to how language is used in a discipline, but also to the nature of knowledge and the social practices of a discipline – in other words, how knowledge is developed and structured in a discipline, the ways of thinking of experts in that discipline, the way in which the discipline represents its knowledge, the use of symbolic expressions, artefacts, tools and so on (Boughey & Van Rensburg, 1993; Lea & Street, 1998). The terms ‘academic literacy’ and ‘academic literacies’ (in the plural) tend to be used interchangeably in the literature, with the plural form emphasising that different literacies operate within specific disciplines, and in different contexts within disciplines. Arbee (2012) emphasises that epistemological access ought to be regarded as discipline specific, meaning that ‘one gains “epistemological access” to a discipline by acquiring the “academic literacies” that enable one to participate in the discourse of that discipline; and that this involves both *knowledge* and *social* dimensions’ (Arbee, 2012: p. 18, my italics added).

Research on academic literacy is relatively new in higher education, with earlier work on student learning since the 1970s being mainly cognitively inspired (for example, Marton, Hounsell & Entwistle, 1997; Marton & Säljö, 1976). Research in academic literacy began to develop during the 1990s (Lea & Street, 1998), with an initial focus on student reading and writing. Lea and Street (1998) note that student reading and writing are the ‘central processes through which students learn new subjects and develop their knowledge about new areas of study’ (p. 158). In their seminal paper on student writing, they argue that three main perspectives or models are discernable: ‘study skills’, ‘academic socialisation’ and ‘academic literacies’. The study skills perspective assumes that:

mastery of the correct rules of grammar and syntax, coupled with attention to punctuation and spelling, will ensure student competence in academic writing; it is, therefore, primarily concerned with the surface features of text (Street, 2009: p. 4).

Jacobs (2005) agrees with this, pointing out that academic literacy ‘is best acquired by students when it is embedded within the contexts of particular academic disciplines’ (p. 477), and not when addressed in stand-alone language intervention programmes, with the assumption that students are experiencing difficulties with English (see also Boughey, 2002). Maton (2009) has similarly criticized generic ‘language skills’ courses for exhibiting ‘knowledge-blindness’, in other words, for not taking into account disciplinary norms. The second perspective revolves around ‘academic socialisation’: ‘this assumes [that] students need to be acculturated into the discourses and genres of particular disciplines and that making the features and requirements of these explicit to students will result in their becoming successful writers’ (Street, 2009: p. 4). The third perspective – ‘academic literacies’ – ‘is concerned with meaning making, identity, power [and] authority and foregrounds the institutional nature of what “counts” as knowledge in any particular academic context’ (Street, 2009: p. 4). For the student moving between discipline contexts, there is a requirement ‘to switch practices between one setting and another, [and] to handle the social meaning that each evokes’ (Lea & Street, 1998: p. 159). It is important to note that Lea and Street do not view these three perspectives or models as mutually exclusive.

Academic literacy may well be seen as a process of ‘acculturation’, which requires new students to develop an understanding of how their discipline culture works if they are to become part of its social practice (McKenna, 2004). In characterizing this discipline culture, Gee’s concept of Discourse (with a capital ‘D’) is useful (Gee, 1990). Gee makes a distinction between ‘little d’ discourse, which tends to be associated with language, reading and writing, and ‘big D’ Discourse, which is concerned with broader values and worldviews. For Gee, Discourse is associated with the particular ways of ‘behaving, interacting, valuing, thinking, believing, speaking, and often reading and writing’ (Gee, 1996: p. viii), which characterise a particular discipline community. However, making overt or explicit the literacy practices and Discourse of a discipline is not straightforward (Northedge, 2003). Jacobs (2007b) argues that lecturers are so immersed in their respective disciplines that their knowledge of the literacy practices and Discourse features of their discipline tends to be tacit and often taken for granted and that they may therefore find it difficult to make it explicit to their students. To help to make the tacit explicit, Jacobs proposes that collaborative partnerships between academic literacy practitioners and disciplinary lecturers might be helpful.

Academic literacy provides a powerful way of understanding why so many students struggle with university science. In relation to reading and writing science texts, Paxton and Frith (2014) have pointed out that ‘writing in quantitative disciplines like science presents particular challenges in terms of students’ academic literacy. In scientific writing one uses terms and phrases that often include everyday words, but which have specific meaning, and which convey a richness of discipline-specific conceptual meaning’ (p. 176). These words are often nominalisations, condensing a complex process or phenomenon into a single word (Brookes, 2006). Lemke (2001), similarly, notes that the language of science – unlike the narrative structure of many other subjects – is ‘expository’ and ‘analytical’. In the case of second language learners, Rollnick (1998) notes that students’ academic difficulties are sometimes interpreted as ‘purely language problems’ (p. 128), whereas an academic literacy perspective would view the issue as more complex.

Within physics education, in particular, academic literacy would entail more than just reading and writing science texts; Linder, Airey, Mayaba and Webb (2014) use the

term ‘disciplinary literacy’ to refer to ‘the ability to competently deal with the various representational formats used within the discipline. For physics the development of disciplinary literacy involves competence in a wide range of representations, such as written and oral languages, diagrams, graphs, mathematics, apparatus and simulations’ (p. 242). More broadly, academic literacy also encompasses an understanding of how physics knowledge is developed and structured. Airey and Linder (2009) argue that fluency in the ‘disciplinary discourse of physics’ is an important part of becoming a successful physics learner. The link between epistemological access and physics education research (PER) is dealt with further in Chapter 2.

### **1.3 Context of the study**

As noted above, the broader context of this study is the concern of widening access to higher education in the context of a very unequal and racially divided South African educational system. Within South African universities, initiatives to widen access to science studies have their origins in the early 1980s at some of the historically white universities. As Kloot, Case and Marshall (2008) note, ‘[t]he first “bridging” programmes at the white, English-medium universities were a means of academic support that were offered to assist small numbers of black students’ (p. 800).

These early academic support programmes were often entirely separate, consisting of non-credit bearing courses, which left the mainstream programmes largely unchanged. As criticism of these ‘add-on’ academic support programmes grew, the approach at many universities shifted from *academic support* to *academic development* (see Volbrecht & Boughey, 2004, for a more detailed analysis of this shift). Here, academic development signalled the need for developing the institution’s capacity to meet students’ needs; this led to the integration and extension of academic development initiatives into the mainstream programmes. In the context of undergraduate science, a variety of different forms of credit-bearing extended degree programmes or ‘foundation programmes’ were introduced at some universities (for a comprehensive overview of science programmes, see Kotecha, Allie & Volmink, 1997; Pinto, 2001; Rollnick, 2010).

From the mid-2000s, government funding was made available for so-called access or foundation programmes in South African higher education institutions. In 2007, increased funding was designated for extended curriculum programmes (ECPs), but these programmes had to meet strict criteria to be counted as foundation programmes (Department of Education [DoE], 2001). These programmes were intended to provide ‘underprepared’ students (students with marginal educational backgrounds in relation to the curriculum-related requirements) with the means to access and succeed in university courses (Boughey, 2005, 2007, 2010a; DoE, 2001; Garraway, 2010). In other words, enhancing and improving students’ retention, access, success and throughput is the underpinning motive behind the ECPs.

At the University of the Western Cape (UWC), the Science Faculty ECP was introduced in 2007, to cater for students who arrived at university, underprepared to succeed in a mainstream first year programme (Holtman & Marshall, 2008). In the Physics Department, in particular, the programme centres on the foundation physics and mathematics offerings, which are full credit courses over two years (Lesia, Marshall & Schroeder, 2007). This model can best be described as a ‘slow-intensive’ programme with additional innovative content, whose purpose is to address student under-preparedness (Boughey, 2010a).

The design of the Extended Physics course drew on previous educational development work done in the UWC Physics Department, which has a long history of innovation and commitment to undergraduate teaching and learning. The university as a whole has had a long-standing emphasis on academic development initiatives infused into the mainstream (see for example, Mehl, 1988; Walker & Badsha, 1993). In the Physics Department, this earlier academic development work included the development of computer assisted learning by Mehl, a focus on students’ conceptual understanding (Linder & Hillhouse, 1996), the nature of physics knowledge (Holtman, Marshall & Linder, 2004; Linder & Marshall, 1998) and physics tutor development (Linder, Leonard-McIntyre, Marshall & Nchodu, 1997).

The design of the Extended Physics course was also influenced by other international physics curriculum initiatives, in particular, a similar initiative being undertaken at Rutgers University in the United States of America, which is framed with the

educational goal of helping students to ‘think like physicists’ (Etkina & Van Heuvelen, 2007). The UWC Extended Physics course specifically focuses on the nature of physics knowledge, and how this knowledge is developed and structured. There is also an emphasis on making explicit the ways in which disciplinary knowledge is represented in various forms – spoken, written, mathematical or image-based forms (including pictures, graphs and diagrams) – as well as the ways of solving problems and reading scientific texts. This was framed by a perspective of helping students to access the disciplinary discourse of physics (Herbert, Conana, Volkwyn & Marshall, 2010; Marshall & Case, 2010). In this way, the foundation is laid for the sorts of capabilities that physics graduates would be expected to have (IOP, 2010; Quality Assurance Agency for Higher Education [QAA], 2002; SAIP, 2004; CHE-SAIP, 2013). The relevant research literature in physics education is reviewed further and in more detail in Chapter 2.

From 2010, I was appointed as an academic literacy practitioner in the Extended Physics course. My role was to work alongside the physics lecturers in helping them to infuse academic literacy into the discipline and to make explicit to students the aspects of the disciplinary discourse described above (see Marshall, Conana, Maclons, Herbert & Volkwyn, 2011 for details). This is the collaborative model, which Jacobs (2007a) writes about. In such collaborations, the role of the academic literacy practitioner would be to help lecturers in a specific discipline to identify the literacy practices of that discipline more explicitly, and to assist them in developing classroom activities to make these practices explicit to students. While engaged in this work as an academic literacy practitioner, I began to wonder about the effectiveness of the Extended Physics course. I was interested in exploring whether the extra time in the Extended Physics course and the explicit focus on academic literacy was in fact fostering a different pedagogy and different student learning outcomes. These initial questions began to form the basis of my study.

The study examines two first year undergraduate physics courses offered in the UWC Physics Department – a traditional course, which is part of the three-year mainstream programme, and an Extended Physics course, which is part of the four-year ECP. The Extended Physics course offers the traditional first year physics curriculum over two years. Hereafter, these courses are referred to as the Mainstream and Extended

courses. It is important to note here that the study goes beyond a simple comparison of these two courses. Rather, the study examines the affordances that the ‘extra time’ in the Extended course might allow: given that the Extended course spends more time on the first year curriculum, the study examines whether the ‘extra time’ in the Extended course does in fact lead to different pedagogical practices and student learning outcomes in relation to the traditional Mainstream course.

#### **1.4 Introducing the theoretical framework**

This study addresses the issue of epistemological access to university science, where epistemological access is framed in terms of an academic literacy perspective. Theoretically, this study uses concepts from the sociology of knowledge to look at curricular and pedagogical conditions that attempt to support students’ success in undergraduate physics. This theoretical framework is described in detail in Chapter 3; a brief overview is presented here.

The study draws on the sociological work of Maton, which expands on Bernstein’s work, in particular his characterization of knowledge structures, curriculum structures and pedagogy (Bernstein, 2000). Maton (2007, 2008, 2014a) examines how curriculum and pedagogy might enable or constrain students’ cumulative learning, which he defines as learning in which ‘new knowledge builds on and integrates past knowledge’ (Maton, 2009: p. 44). Maton has combined some of these concepts into what he has called Legitimation Code Theory (LCT). This approach examines ‘the competing claims to legitimacy, or messages as to what should be considered the dominant basis of achievement within a social field of practice’ (Maton, 2009: p. 45).

Within LCT, I am drawing on the dimension of Semantics, with its analytical concepts of semantic gravity (SG) and semantic density (SD) (Maton, 2009). *Semantic gravity* is defined as the extent to which meaning ‘is related to its context of acquisition or use’ (Maton, 2009: p. 46), and *semantic density* is seen as ‘the degree to which meaning is condensed within symbols (a term, concept, phrase, expression, gesture, etc.)’ (Maton, 2008: pp. 7–8). These theoretical concepts seemed particularly useful in characterizing physics teaching and learning, since they are able to characterize the shifts between concrete and abstract that occur in physics, as well as



the dense representational aspects of physics. Concepts from Maton's Semantics have been used in a few previous physics education studies (Georgiou, Maton & Sharma, 2014; Lindstrøm, 2010). This literature will be reviewed in more detail in the theoretical framework section of Chapter 3.

This study sets out to characterize the pedagogical practices and student learning in two different introductory physics courses; methodologically, the study contributes to the field by exploring the practicality of using aspects of Maton's LCT in analysing the pedagogical practices of physics lecturers, as well as lecturers' and students' approaches to physics tasks in the Mainstream and Extended courses. Shifts in SG and SD are analysed in the pedagogical practices and students' learning. These shifts are then represented diagrammatically in the form of a 'semantic profile' (Maton, 2013) for each lecture sequence or student physics task. Details of how this is done will be discussed further in the methodology section of Chapter 4.

## **1.5 Research questions**

Considering the importance of widening epistemological access to science studies, and building on the theoretical perspectives introduced above, this study aims to address the following research questions:

- What is the nature of the Mainstream and Extended pedagogical practices in terms of their semantic profiles (i.e. semantic gravity and semantic density)?
- What is the correspondence between the pedagogical practices and the ways in which the students approach physics tasks in the Mainstream and the Extended Physics courses?

## **1.6 Overview of the thesis structure: Chapter outline**

Chapter 1 has introduced this study. This chapter has also provided the background and rationale of the study, and introduced the theoretical framework for the study, and the research questions.

Chapter 2 provides a literature review of relevant physics education research (PER), including an overview of science learning and conceptual change, the social context

of learning (including interactive engagement [IE] in physics teaching), as well as an overview of research on the use of representations in the teaching and learning of physics.

Chapter 3 discusses in detail the theoretical framework for the study, Maton's Legitimation Code Theory (LCT) and Semantics.

Chapter 4 discusses the methodology and methods used in the study. It outlines how data was gathered, how the analytical tools were developed, and how the data was analysed.

Chapter 5 provides more details about the setting of the study, viz. the introductory physics context at UWC.

Chapters 6, 7 and 8 present the data relating to pedagogical practices in the Extended and the Mainstream courses. Chapter 6 analyses two lecture sequences that occur *at the same time* during the year, but with different content; Chapter 7 analyses two lecture sequences with *very similar content*; lastly, Chapter 8 focuses in particular on part of a lecture that deals with a particular *physics problem task*.

Chapter 9 analyses how students go about tackling physics problem tasks.

Chapter 10 discusses and summarises the findings from the analyses contained in Chapters 6 to 9.

Chapter 11 concludes the thesis by discussing the implications of the research for undergraduate physics teaching and learning in South African universities, and will also outline possible future areas of research.

## **Chapter 2:**

### **Review of Physics Education Research Literature**

#### **2.1 Introduction**

Chapter 1 highlighted the importance of widening access to science studies, in the context of a very unequal and racially divided South African educational system. In this chapter, epistemological access was framed in terms of ‘acquiring the “academic literacies” that enable one to participate in the discourse of that discipline’ (Arbee, 2012: p.18). The aim of Chapter 2 is to examine more specifically how epistemological access is dealt with in the physics education research (PER) literature; in other words, the chapter examines how students are inducted into physics knowledge and how this knowledge is produced and represented.

Worldwide, there have been many studies over the past few decades in the field of PER, with the aim of enhancing students’ learning of physics. These studies emerged from lecturers’ concerns that physics students were coming to university physics with extensive gaps in their understanding of physics, and that many students were passing traditional physics courses without understanding basic physics concepts (for example, Mazur, 1997; McDermott, 1984). These concerns led physics researchers to draw on various education frameworks in order to understand and investigate physics learning. In the sections that follow, I review the literature on science learning and conceptual change theory, then the social context of learning (including student engagement), and finally the research on representations in physics learning.

#### **2.2 Science learning and conceptual change**

Research on students’ conceptual development began originally in the context of school science. Researchers noted that one of the barriers to students understanding scientific concepts was the intuitive concepts about the natural world that students brought with them into the classroom (see, for example, Driver & Easley, 1978). These led students to hold what were termed ‘misconceptions’ or ‘alternative conceptions’. Science education research then looked at how teaching strategies could help students to give up their intuitive concepts and adopt more scientific ones. This

was termed the ‘conceptual change’ model (Posner, Strike, Hewson & Gertzog, 1982). Researchers in science education consequently turned to the task of identifying students’ prior ideas, and sought instructional strategies that would successfully help students to transform their intuitive concepts into more scientific alternatives (White & Gunstone, 1992).

In thinking about conceptual progression, theorists drew on cognitive psychology. One of these theorists was Bruner, who has significantly influenced the development of curriculum theories (see Bruner, 1960, 1966, 2006). In his work, Bruner (1960) proposed that intellectual ability develops in stages through step-by-step changes in how the mind is used. This reinforces the notion of scaffolding, where the emphasis might be on integrating the new knowledge, which is explicitly presented to students, into their existing knowledge. Bruner calls this kind of development a spiral curriculum – ‘a curriculum, as it develops, should revisit these basic ideas repeatedly, building upon them until the student has grasped the full formal apparatus that goes with them’ (1960: p. 13). Bruner notes that education is not merely a process of getting a student to learn content knowledge:

We teach a subject not to produce little living libraries on that subject, but rather to get a student to think ... for himself, ... to take part in the process of ‘knowledge-getting’. Knowing is a process, not a product (1966: p. 72).

These theoretical ideas – with their origins in cognitive psychology – were subsequently taken up in research on university science learning. In the context of undergraduate physics, these studies focused on physics students’ knowledge structures in terms of schemas, phenomenological primitives and conceptions (DiSessa, 1988, 1993). Some focused on the differences in knowledge structures between experts and novices (Larkin, McDermott, Simon & Simon, 1980). More studies acknowledged the ways in which students tend to conceptualise key physics concepts (for example, Hewson, 1982; Linder & Erickson, 1989; McDermott, 1984). Research on students’ conceptions of physics concepts thus further expanded the conceptual change model, which had originated in school science (see, for example, McDermott, Rosenquist & Van Zee, 1987; Redish, 1994; Sokoloff & Thornton, 1997). The importance of taking into account students’ prior knowledge was again emphasised. Shaffer and McDermott (1992) – echoing Ausubel’s (1968) classic

maxim – note that, in conceptual learning environments, students need to construct their own knowledge and in that construction, it is important that the prior knowledge the students bring with them is taken into account.

Physics education studies complement Bruner's argument above, in emphasising the significance of knowledge structures in the context of the hierarchical nature of physics knowledge. McDermott and Shaffer (2000) argue that many students lack the fundamentals for even the regular introductory physical sciences courses because of the hierarchical structure of the subject matter in sciences, which requires a progression through a prearranged sequence of developments. They argue that, 'the process of gradually refining a concept can help develop an appreciation of the successive stages that are involved in developing a sound conceptual understanding' (pp. 75–76). In more recent work, other researchers have encouraged the use of the framework of scaffolding in physics curricula, designed to maximise students' conceptual understanding (see Lindstrøm, 2010; Lindstrøm & Sharma, 2009, 2011).

In the 1990s and into the 2000s, these models have been extensively debated, developed and also criticized by PER researchers. For example, Linder (1993) challenged the conceptual change model and argued that it is inadequate to portray meaningful learning as change of conceptions, since, without consideration of the context, even many physics conceptions cannot be viewed as 'correct' or 'incorrect'; thus conceptual change as a model for learning needs to be understood in terms of changing one's relationship with the context. He extended his argument in collaboration with Airey, and pointed out that students need to be 'fluent' in the 'mode of disciplinary discourse' before they can completely experience the disciplinary ways of knowing (see Airey & Linder, 2009: p. 33). Another critique of the conceptual change model is the 'knowledge-in-pieces' or 'resources' perspective, which sees conceptual change not as immediate, but as a gradual development in the coherent and consistent application of knowledge systems composed of various resources (DiSessa, 1993).

Hammer and Elby (2000) note that, in addition to developing conceptual understanding, another important aspect of appreciating the knowledge structure of science is developing an understanding of the nature of scientific knowledge itself:

... just as research on conceptual understanding has assumed naïve physics to be made up of “misconceptions” (e.g. “motion requires force”) that differ from expert conceptions (“acceleration is caused by force”), research on epistemologies has understood students to have “misbeliefs” (e.g. “knowledge is certain”) that differ from expert beliefs (e.g. “knowledge is tentative”) (p. 4).

Similarly, Hestenes (1992) argues that students need to be explicitly taught that doing physics is essentially a ‘modelling game’. From this perspective, accessing the disciplinary discourse of physics would require an understanding of the nature of physics knowledge: namely, as a way of modelling the natural world, in an abstract and idealized manner; as tentative and refutable, rather than as fixed; as a coherent and unified knowledge structure rather than as a collection of separate concepts (Hammer & Elby, 2000; Ibrahim, Buffler & Lubben, 2009; Lederman, 1992)

### **2.3 The social context of learning**

While most of the conceptual change studies reviewed above looked at learning from a cognitivist perspective, within science education in general, there has been a growing recognition of the social context in which learning takes place. Driver and her colleagues, in their key paper in the mid-1990s, point out that scientific knowledge is constructed in social contexts, and that social context is also significant for science learning (Driver, Asoko, Leach, Mortimer & Scott, 1994):

[S]cientific knowledge is both symbolic in nature and also socially negotiated. The objects of science are not the phenomena of nature but constructs that are advanced by the scientific community to interpret nature (p. 5).

The challenge lies in helping learners to appropriate these models for themselves, to appreciate their domains of applicability and, within such domains, to be able to use them (p. 7).

In addition, Leach and Scott (2003) suggest that there are constraints to an exclusive emphasis on a cognitivist perspective on learning:

[I]nsights about students’ “mental structures” are useful in explaining why science is difficult to learn for many students. However, [...] such insights are not enough to explain how students learn science in classrooms. Consideration of the social environment through which learners encounter scientific ideas is also necessary (p. 93).

Lemke echoed this notion and pointed out that, ‘people acquired the habits and values of their communities by active social participation’ (2012: p. 80).

Learning science – specifically physics, as in the context of this study – is therefore not only about the learning of content but also about social practices, because students are required to take on particular vocabularies, ways of reading, talking, writing, listening, solving problems and discussing, and also ways of thinking and behaving like physicists. For instance, the multiple representations approach of Van Heuvelen should not just be regarded as a problem-solving skills approach (Van Heuvelen, 1991a), but as a way of assisting students to take on particular ways of acting that characterise the social practices of physics (see Section 2.5 for further details). Moreover, if students are thinking about formulae in terms of recipes for solving problems rather than getting to the fundamental principles of understanding how to solve a problem, they are unlikely to be able to think about physics in terms of a coherent structure of concept-based problem-solving approaches, like practicing physicists do (Wieman & Perkins, 2005). However, when students are modelling an object as a particle to represent a physical interaction, are able to describe this verbally and represent it symbolically, and are able to evaluate their solutions, then, as Hewitt (1983) points out, this is a critical aspect of coming to understand physics. This approach considers the ways in which the physics community engages with the discipline of physics, as pointed out by Wieman and Perkins (2005) – not as disconnected pieces of information to be memorised without understanding, but rather as a coherent, unified knowledge structure.

Several studies have examined physics curriculum design from a socio-cultural perspective on physics learning. Van Heuvelen has framed a reform curriculum referred to as Overview Case-Study Physics (Van Heuvelen, 1991b), and, more recently, the Investigative Science Learning Environment (ISLE) project (Etkina & Van Heuvelen, 2007) – with a focus on helping students to ‘think like physicists’. Airey and Linder (2009) view physics learning in terms of developing fluency in a critical constellation of modes of disciplinary discourse.

All of these studies recognise the social contexts of learning and place a great emphasis on learning as participation in a discourse community, and inducting

students into the ways of thinking and habits of mind that characterise the specific social practices of physics. If researchers adopt the point of view that there are useful insights to be gained by inducting and exposing students to their broader community of practice, then there also has to be a move from traditional lectures towards creating classroom communities focused on student engagement (see, for example, Fredlund, Linder & Airey, 2014). What follows is a review of current research on science teaching.

## **2.4 Research on university science teaching**

For many years, considerable research-based work in the area of PER has been aimed at identifying effective means of improving teaching and learning in undergraduate physics. The motive behind the PER research-based work was to better understand students' experiences of learning and to improve students' learning outcomes. Wieman and Perkins (2005) argue that '*effective*' physics teaching is teaching that 'changes the way students think about physics and physics problem-solving and causes them to think more like experts – like practicing physicists' (p. 36). This comes from the concern that traditional physics teaching approaches may not be the most effective for the average student. The dominant mode of undergraduate physics teaching internationally has been the traditional lecture format, often referred to as 'talk-and-chalk', where the lecturer talks most of the time, with little student interaction. However, over recent decades, education research has shown that student engagement can enhance learning outcomes (see, for example, Hake, 1998).

Education researchers have used different terms to describe various forms of student engagement. For example, Johnson and Johnson (1991) define 'co-operative learning' as the process whereby students work together in small groups to maximise their own learning and that of their peers in the group. Similarly, Damon and Phelph (1989) call this 'collaborative learning', whereas Lindstrøm (2010) refers to it as a 'mutual engagement of group members in a challenging task where all members jointly work on the same problem' (p. 48). In undergraduate science teaching, the term 'interactive engagement' (abbreviated as IE) is widely used to characterize teaching approaches that are 'designed at least in part to promote conceptual understanding through interactive engagement of students in heads-on (always) and hands-on (usually)



activities, which yield immediate feedback through discussion with peers and/or instructors' (Hake, 1998: p. 65). Hake's seminal study on IE (1998) showed that, in undergraduate physics classes with more IE, the development of students' understanding of concepts was significantly improved. Similarly, IE is evident in an analysis of the literature of 'promising practices in undergraduate science' (see Froyd, 2008: p. 1). Deslauries, Schelew and Wieman (2011) have also recently argued that IE is the most effective approach that teachers can introduce into their pedagogical practices.

There are various forms of IE pedagogy, some of which are reviewed in this section. One of these IE pedagogies is 'Peer Instruction' (Mazur, 2007), also referred to as the 'convince your neighbour discussion' (Mazur, 1997: p. 12) and the use of 'clicker questions' (Mazur, 2009). 'Clicker questions' are used when students are given multiple choice questions and use an electronic device (a 'clicker') or their cellphone to answer their questions, individually. When the students are answering, they are allowed to discuss with one another in groups or pairs and then, after their discussion, they are given another chance to change their answers, if they have been convinced by their pair or group discussions. Thereafter, the right answer is shown to them by the teacher. After their first and second attempts at answering the question, the data, which shows how they performed is presented, so that they can see whether their peer discussions have helped them to develop their understanding and therefore arrive at the right answer.

Another research-based form of IE is 'Active Learning' (Etkina & Van Heuvelen, 2007; Van Heuvelen, 1991a), which is a teaching approach that lets every student in a big lecture room be an active member. Here, a student is working together with a student who is close-by while they are answering questions. If the students prefer to work individually, they can do so; when they are done with that activity, they need to compare their solutions with each other, and talk about them to arrive at a consensus. The lecturer monitors and facilitates the process by asking questions to offer some guidance, if the students appear to be confused when they are discussing their solutions. After they have been given time to work with their peers, the lecturer gives feedback. The purpose of this activity is to assist students to develop a qualitative understanding of physics concepts and skills like, for example, the use of free-body

diagrams (FBDs), etc. Above all, the activity is structured in such a way that it motivates students to use different representations when attempting to solve a problem.

Enghag, Forsman, Linder, MacKinnon and Moons (2013) have pointed out the advantages of giving physics students the opportunity to ‘talk about’ new concepts soon after they have been introduced – they refer to this as Peer Talk. They argue that these types of pedagogical practices ‘foster a pedagogically rich exchange of knowing in an environment where students feel “safe enough” to engage... in an open and honest way’ (p. 645). Their study used the communicative approach model of Mortimer and Scott (2003) to characterize the different pedagogical practices in physics classrooms. This two-dimensional model characterises communication between teacher and students as *interactive/non-interactive* and *authoritative/dialogic*. While acknowledging the benefits of using a variety of communicative approaches, Enghag et al. (2013) note the importance of a dialogic approach for students ‘to feel included in the physics disciplinary discourse and to help them proceed towards disciplinary fluency’ (p. 646). (The framework developed by Mortimer and Scott [2003] for charactering science teaching is used later in the data analysis in my study).

In summary, IE is associated with students’ improved understanding of key disciplinary concepts. In addition, IE has also been shown to improve students’ abilities to understand the different representations that are used in physics generally (Enghag et al., 2013). The following section will provide an overview of the PER work on representations in physics.

## **2.5 Representations in the teaching and learning of physics**

As noted in Chapter 1, the disciplinary discourse of physics is characterized by various sorts of representations. These include, for instance, the role of language in learning physics qualitatively – speaking, writing, reading and listening – as well as diagrams, graphs, equations, and other symbolic forms. Similarly, the use of tools as experimental and measurement devices plus the activities in the manner one works are also sometimes included in what is characterized as ‘disciplinary discourse’ (Airey & Linder, 2009). Since representations form an important part of my study, this section

provides a detailed review of the research on representations in physics education, in particularly addressing students' difficulties with using representations, the role of representations in tackling problems, and implications for teaching.

In an early paper on representations in physics, Van Heuvelen (1991a) notes that students' understanding of physics often 'consists of random facts and equations that have little conceptual meaning' (p. 894). He points out that students fail to appreciate the 'conceptual unity' and 'knowledge hierarchy' of the discipline (1991a: p. 894). Elby (1999), similarly, notes that students experience the discipline as a collection of unrelated topics, each with a host of equations to memorise, with little sense of the hierarchical unity of physics that physicists appreciate. Moreover, as Van Heuvelen notes, students tend to view physics problem-solving as 'almost entirely formula-centred – devoid of qualitative sketches and diagrams that contribute to understanding' (1991a: p. 891).

This view of physics on the part of students differs markedly from how experienced physicists view physics. Van Heuvelen (1991a) notes that physicists depend on '*qualitative* analysis and representations to understand and help construct a mathematical representation of a physical process' (p. 891). Van Heuvelen has suggested that one of the key things that can be done in order to make students understand the conceptual unity of physics that physicists appreciate, as well as the representational aspects, is to have an applicable way of teaching and addressing the students' insufficiencies. Therefore, since students are beginners in the field, they have to learn to 'think like a physicist', by learning to explain physical processes or phenomena and to represent these using 'multiple representations' (1991a).

Van Heuvelen (1991b) and Etkina and Van Heuvelen (2007) have developed physics curricula that explicitly emphasise the use of representations, viz., Overview Case-Study Physics and more recently, the ISLE project. These curricula help students to:

1. construct *qualitative representations* of physical processes and problems,
2. reason about the process using these *qualitative representations*,
3. construct mathematical representations with the help of the qualitative representations, and
4. solve the problem *quantitatively* (Van Heuvelen, 1991a: p. 892).

Van Heuvelen and Zou (2001) expand on points 1–4 above and note that the ‘*multiple representations*’ usually include:

- the *verbal* representation of the process (describe in words),
- a *pictorial* representation (draw a sketch or a picture) to represent the process,
- a *physical* representation that involves quantities and descriptions (draw a FBD or a graph), and then
- the *mathematical* representation to describe the process by using basic physics principles (laws and equations) (p. 185).

Van Heuvelen (1991a) and Van Heuvelen and Zou (2001) have highlighted that *pictorial* and *physical* representations are *qualitative* and not *mathematical quantitative representations*.

### 2.5.1 Students’ difficulties with representations

Studies have examined students’ engagement with the various representations used in physics, including verbal representations (Brookes, 2006), vectors (Nguyen & Meltzer, 2003), graphs (Beichner, 1994), work-energy bar charts (Van Heuvelen & Zou, 2001) and FBDs (Rosengrant, Van Heuvelen & Etkina, 2009). In this review, I will deal specifically with research on students’ difficulties with verbal representations and FBDs, since these are the most relevant representations for my particular study.

Looking firstly at *verbal representations*, Brookes (2006) and Brookes and Etkina (2007) indicate that physicists are aware that, when they communicate (speak and write), a number of students have difficulty comprehending what is communicated to them. This is due to the effect of the shared practices and processes that increase the meaning potential in physics learning. Physicists use metaphorical representations, such as ‘*nominalization*’ to reason productively about certain phenomena (Brookes, 2006). Nominalisation is when a complex process or phenomenon becomes condensed into a single word or group of words, for example, ionisation, acceleration or polarisation.

This forms a ‘grammatical metaphor’ (Halliday, 1998). Nominalisation forms the ‘backbone of scientific writing and speech’ (Brookes, 2006: p. 33). They are *condensed representations*: in other words, *nominalisations* and abstract physics concepts are considered to be ‘dense’ as opposed to long, everyday descriptions. It is worth noting that this way of using physics terms can be regarded as the ‘technical’ meaning or technical language of physics (Fredlund, 2013: p. 26). This means that the technical term is legitimated and becomes a ‘taken-for-granted meaning by the community’ that practices the discipline of physics (p. 26). Physicists can thus link a particular meaning with the term, but the usage of that term does not reflect the technical meaning of physics. The difficulty in learning physics in this way is the fact that some of the terms that are being used have everyday meanings too, but these are not the same as the technical meaning. For example, terms such as ‘work’ and ‘power’ have everyday meanings too, in contrast to their specific physics meanings.

FBDs are another important form of physics representation identified in my study. Rosengrant et al. (2009) characterise a FBD as ‘a diagrammatical representation in which one focuses on an object of interest and on the forces exerted on it by other objects’ (p. 0101018-3). Rosengrant et al. (2009) argue that the use of the FBD as a visual representation plays an essential part in problem-solving processes, because it helps students to move from a concrete physical situation to abstract mathematical equations. As a transition stage between a pictorial representation (a sketch) and a mathematical representation, the FBD helps the students appropriately to apply Newton’s Second Law in component form to determine the required unknown values.

When constructing a FBD, the object of interest – called the ‘system’ – is modelled as a point particle and represented as a dot. The textbook used in both the Mainstream and Extended courses notes that a point particle is a simplified version of treating the ‘mass’ of ‘an object’ as ‘concentrated at a single point’, where this mass of an object is considered as ‘a particle that has no size, no shape and no distinction between top and bottom or between front and back’ (Knight, 2007: p 5). This modelling process is referred to as a very significant assumption in physics.

Common difficulties students have with FBDs include omitting or adding extra forces, mislabeling forces, and drawing force arrows of incorrect length (Rosengrant

et al., 2009). Moreover, Rosengrant et al. (2009) found that students have different perspectives on the role of FBDs, with high-achieving students ‘consciously using the representations to reflect on their work and their solutions’ (p. 010108-10). In contrast, low-achieving students only constructed the diagram as if it were part of a mechanical procedure, and ‘just followed steps they had learned in the classroom without having a full understanding of the importance of each step’ (p. 010108-10). The low-achieving students also struggled to use the FBD ‘consistently with other representations’ (p. 010108-10). Not surprisingly, Rosengrant et al. (2009) found that students who drew the FBDs correctly were much more successful in solving problems correctly.

Many studies show that students struggle to move between representations, especially as the meaning implicit in representations is often taken for granted by lecturers. As Brookes and Etkina (2007) point out:

[M]eaning cannot be directly passed, conveyed, or in any way transported from the instructor to the student. The teacher has to help the student construct meaning by elaborating the code. Students can then use this code to decode the words that the instructor uses (p. 010105-1).

Therefore, one of the first abilities students have to develop is the ability to represent ideas and physical processes in different ways and to move between representations (p. 010105-1).

Similarly, Airey and Linder (2009) suggest that, in order for students to attain an applicable inclusive understanding in different ways of representations, they need to develop a ‘*discursive fluency in modes of disciplinary discourse*’:

By discursive fluency we mean a process through which handling a mode of disciplinary discourse with respect to a given disciplinary way of knowing in a given context becomes unproblematic, almost second-nature. Thus, in our characterisation, if a person is said to be discursively fluent in a particular mode, then they come to understand the ways in which the discipline generally uses that mode when representing a particular way of knowing (p. 33).

Several studies have pointed out that teaching needs to focus explicitly on this ability to move between representations. For example, Paxton and Frith (2014) note that ‘the

multimodal approach to knowledge making that is inherent in teaching quantitative subjects can also present obstacles, if it assumed that the relationships between the different kinds of representations are self-evident' (2014: p. 178). Similarly, Tang, Tan and Yeo (2011) have also indicated that no scientific understanding is achievable without students having the literacy abilities to integrate the connections between different multimodal approaches; moreover, 'those connections have to be explicitly made through overt systematic instructions' (Tang & Moje, 2010: p. 82).

Van Heuvelen also notes this lack of overt focus on representations in many undergraduate physics courses: 'there is very little explicit instruction and practice with individual skills such as constructing pictorial representations, free-body diagrams, motion diagrams, and changing a free-body diagram to Newton's second law in component form' (1991a: p. 893). Linder et al. (2014) characterize a range of lecturers' responses to their students' lack of representational competence, including avoidance of problematic representations or active engagement with helping students develop representational competence. In terms of solving physics problems, in particular, Leonard, Dufresne and Mestre (1996) note that, in traditional undergraduate physics courses, the instructors tend to communicate verbally the principles or concepts to be applied in physics problems, but students only see the written equations on the board, and not the conceptual explanations nor details of the representational aspects. In learning physics problem-solving, the latter are often not made sufficiently explicit to students. Dancy and Henderson (2010) note that lack of time is often cited by lecturers as a hindrance to implementing teaching innovations such as an explicit focus on representations.

### *2.5.2 Representations in tackling physics problems*

Rosengrant et al. (2009) note that the verbal problem statements in typical physics problems are already abstracted. Similarly, Georgiou et al. (2014) note that typical physics questions tend to avoid real-world physical situations and assume idealisations (for example, frictionless, ideal gas, etc.). To counter this, context-rich problems (Heller & Hollabaugh, 1992) require that students solve problems in a more real-world context: they are expected to figure out what physics principles are

applicable to the physical situation, to ascertain which given information is useful and which is extraneous, and to make simplifying assumptions.

Rosengrant et al. (2009) note that many students avoid the use of qualitative representations when they solve physics problems: students move from an *abstract* verbal representation (the problem statement) to an even more *abstract* mathematical representation, without linking these two representations with an intermediate representation, such as a sketch (pictorial representation), a graph or a FBD (a physical representation). Therefore, they argue for the importance of creating a 'representation-rich learning environment, which helps students learn how to use different representations' (p. 010108-2) and therefore to attain what Airey and Linder (2009) term 'discursive fluency' (p. 33) in the disciplinary discourse of physics. Rosengrant et al. (2009) point out that students see the importance of diagrams if they are in an environment where they learn 'how to use' FBDs to develop concepts. In such an enabling environment, students thus 'acquired a habit of using the diagrams' and make sure of using them habitually, once they are 'in an environment' that uses representations regularly (p. 010108-11). This is echoed by Van Heuvelen and Zou (2001), who assert that 'an important goal of physics education is to help students learn to construct verbal, pictorial, physical, and mathematical representations of physical processes, and to learn to move in any direction between these representations' (p. 184).

In order to emphasise the role of representations in problem-solving and to shift students away from a 'plugging values into equations' approach, Van Heuvelen and Zou (2001: p. 193) view physics problems as 'descriptions of physical processes', which require students to represent these processes in multiple ways. Etkina and Van Heuvelen (2007) point out that another reason why students avoid using qualitative representations is that they have insufficient instances and time to advance distinctive practices that are necessary to create representations. If students are to understand representations, and to use them as an integral part of how they habitually approach problem tasks, then they need numerous experiences over an extended period of time.

Van Heuvelen and Zou (2001) point out that students learn better if they know the motive behind applying the different pedagogical approaches, as in the case of FBDs.



Kohl and Finkelstein (2008), similarly, note the importance of discussing the purpose of representations and ‘knowing what different representations are useful for (p. 010111-11). They refer to this as developing students’ ‘metarepresentational competence’. Rosengrant et al. (2009) found that when students are in representation-rich learning environments, which systematically emphasize the use of FBDs, most students use the diagrams as a matter of course, even when marks are not assigned for drawing these diagrams.

## **2.6 Concluding remarks**

This chapter has provided a review of relevant physics education literature, including the literature on physics learning and conceptual change, the social context of learning, research on science teaching (including IE) and the role of representations in physics teaching and learning. It has been shown how physics learning can be understood as a process of developing the capacity to ‘think like a physicist’, as students learn the social practices of the discipline and begin to take on the specific disciplinary discourse. Larkin et al. (1980: p. 1338), in their earlier work on physics problem-solving, have argued that it is crucial to understand the ‘semantics’ of the physical object in a process or phenomenon. This chapter has shown how meaning in physics is condensed in various representations (nominalisations, sketches, diagrams, mathematical formulae, etc.) and that students are required to develop the expertise to make transitions between representations, as these representations are the way in which physics knowledge is presented and communicated.

In order to characterise the conceptual unity in physics, the moves from concrete to abstract, as well as the semantically dense nature of the representations used in physics, I required a theoretical framework that would be well-suited to capture these disciplinary aspects. As noted in Chapter 1, I have chosen to use the Semantics dimension of LCT (Maton, 2009). The next chapter, Chapter 3, will explain my choice of this dimension of LCT to frame my research.

## **Chapter 3:**

### **Theoretical Framework**

#### **3.1 Introduction**

This chapter presents the theoretical framework of my research study, which draws on aspects of Maton's Legitimation Code Theory (LCT). Since Maton's work has its roots in Bernstein's (2000) theoretical ideas, a brief overview is also presented below of Bernstein's work, in order to give a context for Maton's concepts. Furthermore, I explain why I have chosen to use Maton's LCT as the preferred theoretical framework.

In the brief review of the education research on 'epistemological access' and 'academic literacy', Chapter 1 demonstrated how this literature has shown the usefulness of viewing literacy in terms of developing an understanding of the nature of knowledge and the social practices of a discipline. Therefore, enabling 'epistemological access' requires an engagement with both the content knowledge and the ways of knowledge development in that particular discipline (Boughey, 2005), in addition to dealing with students' identities (Boughey, 2008; Marshall & Case, 2010; McKenna, 2004). The conceptualisation of 'epistemological access' has emphasised that 'epistemological access' may be regarded as being discipline specific, meaning that 'one gains "epistemological access" to a discipline by acquiring the "academic literacies" that enable one to participate in the discourse of that discipline; and that this involves both *knowledge* and *social* dimensions' (Arbee, 2012: p. 18, my italics added).

Chapter 2 reviewed the physics education literature and demonstrated how this research has expanded from focusing on the individuals' acquisition of science concepts to also consider the social context in teaching and learning or acquiring science (physics) knowledge, and thus to signal the way in which the discipline represents its knowledge. In the discipline of physics, for instance, understanding of concepts through representations is basically an integral part of the general objective of learning physics. Physics as the discipline represents its knowledge through the use

of symbolic expressions, verbal, diagrams, sketches, and so on. To acquire the conceptual understanding of physics, students have to move between these representations, and from concrete to abstract constructs or vice versa. Moreover, some of these representations are denser than others, and this is what has to be discerned by students before they can appreciate the disciplinary structures and norms, since this is the nature of the knowledge of physics.

As noted earlier, I have chosen to use the Semantics dimension of LCT (Maton, 2009, 2014a) as the analytical framework for this study. Other frameworks which I had considered using included discourse analysis and the PER framework of representations. However, I found that Gee's framework of d/Discourse did not offer me the necessary tools for fine-grained analysis of physics tasks. While the PER multiple representations framework was very useful in guiding my study, it did not have the same capacity to provide visual display of shifts between representations as LCT does. I was also interested to explore the usefulness of LCT as a tool to characterise the pedagogical practices and student learning in an introductory physics context, given LCT's origins in the sociology of knowledge, rather than the more cognitive science frameworks that are prevalent in PER.

The LCT concepts of 'semantic gravity' (SG) and 'semantic density' (SD) seemed well-suited to characterising the moves from abstract to concrete in physics, as well as the dense nature of the representations used in physics. The LCT framework was developed from the concepts originated by Bernstein, which were mainly focusing on understanding knowledge. This study draws mainly on Maton's work; however, a brief overview is presented below of Bernstein's work on the sociology of knowledge, in order to give a context for Maton's theoretical ideas.

### **3.2 Knowledge structures**

Bernstein's extensive sociology of education research includes earlier work on pedagogical practices in educational contexts and the construction of educational knowledge (through what he calls the 'pedagogic device' – see later Section 3.3). In his later work, Bernstein (2000: pp. 155–174) calls for the transference of research focus from educational knowledge 'to the study of intellectual fields from which this

knowledge is selected and pedagogised in terms of “knowledge structures” (Maton, 2014a: pp. 65–66).

He examines carefully in what manner knowledge changes over time, in addition to considering the diverse ways in which these intellectual or educational fields develop (Bernstein, 1990).

Bernstein presents a way of conceptualising different forms of knowledge, distinguishing between forms of ‘discourse’: *horizontal discourse* refers to everyday or ‘common sense’ knowledge and ‘entails a set of strategies which are local, segmentally organised, context specific and dependent’ (2000: p. 157). This means that the knowledge embraced by this discourse is considered as ‘functional relations of segments or contexts to the everyday life’ (2000: pp. 158–159); that is, the significance of knowledge depends on its social context, thus knowledge developed in a single context does not necessarily have meaning or significance in other contexts. Conversely, *vertical discourse* refers to academic knowledge, namely, the ‘specialised symbolic structures of explicit knowledge’ (2000: p. 160), or to scholarly, professional and educational knowledge, and ‘takes the form of a coherent, explicit, and systematically principled structure’ (2000: p. 157). Here the significance of knowledge is less dependent on its context; instead, it is connected to other meanings hierarchically.

Within vertical discourse, Bernstein makes a distinction between ‘hierarchical’ and ‘horizontal’ knowledge structures: A hierarchical knowledge structure, exemplified by the sciences, is a ‘coherent, explicit and systematically principled structure, hierarchically organised’, which ‘attempts to create very general propositions and theories, which integrate knowledge at lower levels’ (2000: p. 160), and which ‘cover the maximum number of empirical phenomena with the smallest number of axioms’ (Maton, 2009: p. 45). This is in contrast to the horizontal knowledge structure of many humanities or social sciences disciplines. A horizontal knowledge structure is exemplified by ‘a series of specialised languages with specialised modes of interrogation and criteria for the construction and circulation of texts’ (2000: p. 161). A key concern of Bernstein’s model is the way in which that knowledge progresses over time. A hierarchical knowledge structure progresses through new, general

knowledge, integrating and subsuming prior knowledge at lower levels (Bernstein, 1999).

In Bernstein's terms, physics as a discipline epitomises a *hierarchical knowledge structure*, which is characterised by a 'coherent, explicit and systematically principled structure, hierarchically organised' (Bernstein, 2000: p. 160). As the name implies, hierarchical knowledge structures develop through the integration and subsumption of new knowledge; horizontal knowledge structures develop through the addition of non-hierarchically related segments of new topics or approaches (Maton, 2009). This characteristic of tending towards a hierarchical structure is also referred to by Muller (2007) as 'verticality'. Maton (2009) also makes the distinction between hierarchical and horizontal curriculum structures. The traditional undergraduate physics curriculum is hierarchical, reflecting the hierarchical knowledge structure of the discipline, comprising units of study, which each build on the knowledge taught in previous units.

### **3.3 The 'pedagogic device': Fields of production, recontextualisation and reproduction**

The 'pedagogic device' is a concept developed by Bernstein to conceptualise the process whereby discipline knowledge is translated into a curriculum and then advanced into pedagogy (Luckett, 2010). For instance, Bernstein notes that 'curriculum defines what counts as valid knowledge and pedagogy defines what counts as valid transmission of knowledge' (1973: p. 85). This means that the 'pedagogic device' is allied to the process whereby knowledge is 'recontextualised from esoteric knowledge into a more digestible form suitable for educational purposes and settings' (Arbee, 2012: p. 41).

Bernstein's notion of the 'pedagogic device' (2000) is a useful framework for conceptualising how physics as a discipline becomes a physics curriculum, which in turn impacts on students' learning of physics. The pedagogic device operates across three fields – the *field of production*, where new physics knowledge is produced through research, the *field of recontextualisation*, where physics knowledge is recontextualised into the form of a physics undergraduate curriculum, and the *field of*

*reproduction*, which encompasses the pedagogical practices in the classroom. This study is largely situated within the *field of reproduction*.

### 3.4 Classification and framing

Another important contribution of Bernstein's framework is the notion of 'classification', which, at the level of curriculum, refers to the boundaries between categories of knowledge. Physics as a discipline is clearly distinguishable from, for example, chemistry, and so is said to be *strongly classified*. Alongside classification, Bernstein identifies 'framing', which at the level of pedagogical practice refers to 'the degree of control teacher and pupil possess over the selection, sequencing, pacing and evaluation of the knowledge transmitted and received in the pedagogical relationship' (Bernstein, 1975: p. 88). A traditional introductory physics course would be considered to have *strong framing* of selection and sequencing of the content knowledge: the traditional 'canon' of the introductory first year physics curriculum largely determines the topics dealt with, and the ordering of topics would be clearly laid out in course documents and textbooks.

These concepts of classification and framing have been useful for illuminating how the classification and framing of curriculum and pedagogy may hinder or enable learning, especially among working class or traditionally marginalised groups (see, for example, Hoadley, 2006). Morais and Neves (2011), similarly, describe elements of school pedagogical practice that optimize students' scientific learning, including strong framing of selection and sequencing, weak framing of pacing, strong framing of evaluative criteria and weak framing of hierarchy between teacher and student.

In higher education too, the concepts of classification and framing have provided a useful framework for analysing pedagogical practices and how they enable or constrain student learning (Kotta, 2011). In the context of my study, I needed a theoretical framework that would best be able to characterize the movement between abstract and concrete that physics teaching entails, as well as the way in which meaning is encapsulated in the multiple representations of physics. The concepts of classification and framing did not seem to offer this 'interior depth' (Hugo, Bertram, Green & Naidoo, 2008). Rather, it seemed that the Semantics dimension of LCT –

with its analytical concepts of SG and SD (Maton, 2009) – might be the most useful tool for analysing the pedagogical practices and the students’ tasks in physics.

### **3.5 Cumulative and segmented learning**

As noted earlier, Bernstein’s work on knowledge structures (hierarchical and horizontal) analyses how knowledge develops differently in different intellectual fields: hierarchical knowledge structures develop through ‘integration and subsumption’ of knowledge; horizontal knowledge structures develop through ‘accumulation and segmentation’ (Maton, 2009: p. 45). Maton argues that, here, Bernstein’s focus was on the development of *new* knowledge in intellectual fields, but this can also be applied to students’ learning experiences:

[O]ne can distinguish the ways in which students’ understandings develop over time (as evidenced by, for example, their work products), according to whether they build on their previously learned knowledge, and take that understanding forward into future contexts or learn knowledge that is strongly bounded from other knowledges and contexts (2009: p. 45).

Maton calls this *cumulative learning*, ‘where students are able to transfer knowledge across contexts and through time’ (2009: p. 45). Maton distinguishes cumulative learning from *segmented* learning: cumulative learning occurs when the ‘understandings integrate and subsume previous knowledge, new ideas or skills built on past knowledge’; segmented learning would be ‘where new ideas or skills are accumulated alongside rather than built on past knowledge’ (Maton, 2009: p. 44). Furthermore, in his exploration, Maton ascertains in what way educational knowledge (that is curriculum structures) could be useful in developing cumulative learning, where the previous knowledge builds on and applies that understanding to new contexts.

### **3.6 Legitimation Code Theory**

Widening Bernstein’s theoretical framework, Maton explores the fundamental principles structuring the forms of knowledge, through using the concept of legitimation codes within social fields of practice (Maton, 2009, 2013). Maton’s main focus was on determining, from within the social fields of practice, how the forms

taken by educational knowledge (that is, its curriculum structures) may enable or constrain cumulative learning (Maton, 2009, 2013). Hence, Maton develops a new conceptual framework to characterise the fundamental principles that generate the discourses, knowledge structures, curriculum structures and forms of learning in a discipline (Maton, 2009, 2013). Maton calls this conceptual framework LCT, which expands on Bernstein's code theory in conjunction with other research studies, such as, for instance, Moore and Maton (2001) and Maton (2000, 2006, 2007). LCT positions the 'practices and beliefs' as exemplifying what should be considered as the source of 'achievement within a social field of practice' or what actually is being learned and in what way it shapes the development of learning (Maton, 2009: p. 45; Maton, 2013).

Maton describes LCT as a 'multi-dimensional conceptual toolkit; each dimension offers concepts for analysing a particular set of organizing principles (or *legitimation codes*) underlying practices' (Maton, 2013: p. 12). Maton points out that LCT can aid in the exploration of 'knowledge, curriculum, and pedagogy' (2014c: p. 192). It is important to point out that 'Semantics is not the only dimension of LCT', and that 'semantic gravity and semantic density are not the only concepts in Semantics' (Maton, 2014c: p. 192).

The following section focuses on the main analytical framework of this study, that is, the LCT dimension of Semantics – one of the dimensions in the 'multi-dimensional conceptual toolkit' (Maton, 2013: p. 12).

### 3.6.1 *Semantics in LCT*

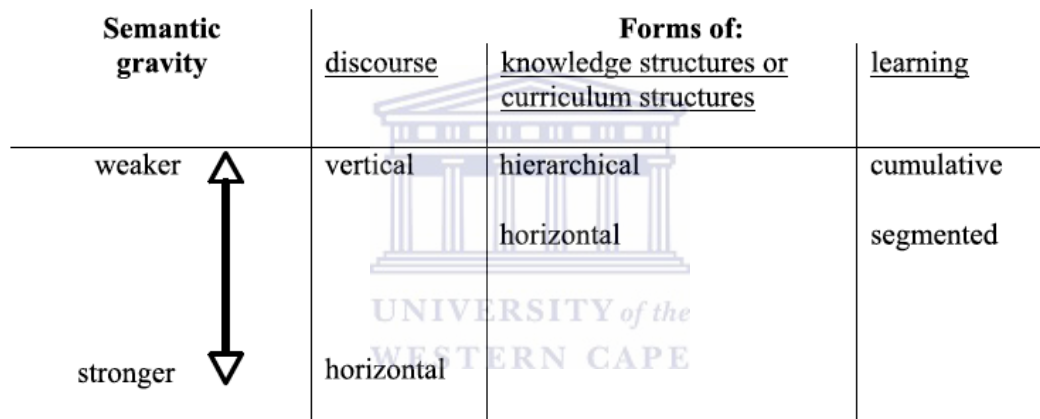
The LCT dimension of Semantics theorises social fields of practice as '*semantic structures*', whose structuring principles are conceptualized as '*semantic codes*' (Maton, 2009, 2011, 2013). The Semantics dimension consists of the two analytical concepts of '*semantic gravity*' and '*semantic density*' (Maton, 2009, 2013). McNamara and Fealy point out that these concepts 'enable a more fine-grained analysis' of a social field's capacity to build cumulative knowledge (2011: p. 120).



### 3.6.2 Semantic gravity

*Semantic gravity* (SG) is defined as the extent to which meaning ‘is related to its context of acquisition or use’ (Maton, 2009: p. 46). When SG is weaker, meaning is less dependent on its context. A hierarchical knowledge structure such as physics operates with abstract, decontextualised concepts and principles, so it is said to have a weaker SG, whereas social sciences could be said to have a stronger SG. Maton (2009) argues that *cumulative learning* depends on SG being weaker:

... cumulative learning depends on weaker semantic gravity and segmented learning is characterised by stronger semantic gravity constraining the transfer of meaning between contexts. Thus, one condition for building knowledge or understanding over time may be weaker semantic gravity (p. 46).



**Figure 3.1: Semantic gravity in relation to the structuring of knowledge (Maton, 2009)**

Figure 3.1 shows the relationship between many of the concepts introduced above – discourses, knowledge structures, curriculum structures, cumulative/segmented learning and SG. Maton (2009) emphasizes that a hierarchical knowledge structure does not necessarily imply a hierarchical curriculum structure, nor that a hierarchical curriculum structure would necessarily give rise to cumulative learning. For example, because physics knowledge is hierarchical, one might expect that learning in physics has to be *cumulative*; that is, it should entail building on previous knowledge, applying understanding to new contexts, and drawing out the underlying physics principles from problem contexts. However, as noted in Chapter 2, specifically in Section 2.5, research shows that physics students often struggle to go beyond the specific context/topics to see the underlying principles in physics or the conceptual

unity of the discipline (Elby, 1999; Van Heuvelen, 1991a). Success in physics learning is determined not only by the amount of concepts that are required to be understood; it is similarly determined by learning the ‘myriad of relations among concepts’ (Lindstrøm, 2010: p. 1). As Lindstrøm and Sharma (2009) note, the nature of physics knowledge is such that abstract physics concepts are strongly linked to other abstract concepts, both within and between physics topics or fields. This reflects the underlying unity of physics, which is the ‘verticality’ of physics. However, students are often unable to discern the overarching relationships between physics concepts, both within and between topics.

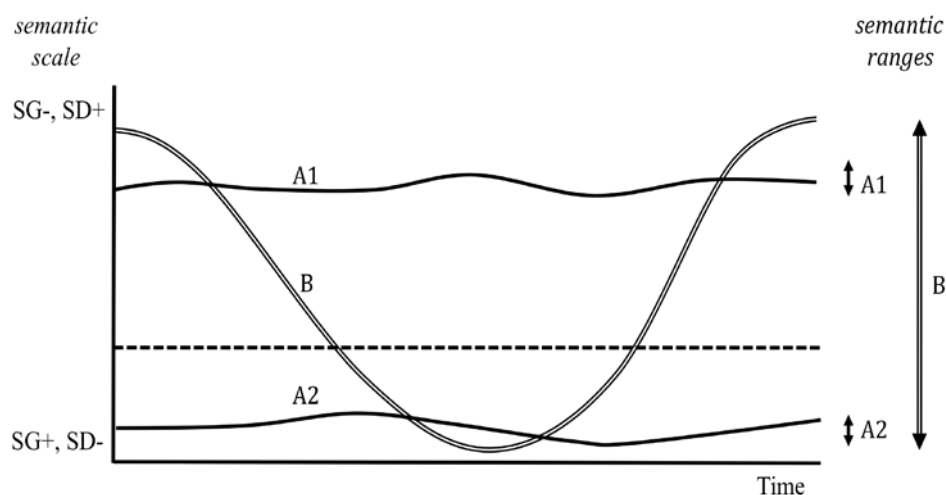
### 3.6.3 *Semantic density*

*Semantic density* (SD) is seen as ‘the degree to which meaning is condensed within symbols (a term, concept, phrase, expression, gesture, etc.)’ (Maton, 2008: pp. 7–8). Physics has strong SD, because meaning is condensed within nominalisations (that is, within scientific words or phrases that are dense in meaning) and within multiple representations – graphical, symbolic, diagrammatic, mathematical, etc. However, the SD of physics is often not made explicit to students; as noted in Chapter 2, research indicates that students struggle with the meaning condensed in words, symbols and representations (Rosengrant et al., 2009; Van Heuvelen & Zou, 2001). Georgiou (2014a) illustrates SD by considering the term ‘gold’, which has a condensed nominalised meaning within physics or chemistry. In everyday experience, the term refers to a bright yellow, shiny and malleable metal used in coinage, jewellery, dentistry and electronics. However, as a scientific term, it is well-known as a chemical element or an atom that can be found in a periodic table. The term has a dense meaning that symbolises an atomic number (number of protons inside the nucleus of an atom), an atomic mass or mass number (number of protons and neutrons inside the nucleus of an atom), with a certain number of electrons (found outside the nucleus of an atom) and a lattice structure (meaning a shiny and malleable metal), and so on. Each concept used here to describe this term has its own specific meaning related to gold, so for students to understand these particulars, there has to be comprehensive learning, which is gradually increasing the complexity and the student’s level of sophistication to understand the term ‘gold’ scientifically.

Although SG and SD are independent constructs, in a discipline like physics, they tend to be inversely related. As Lindstrøm (2010, 2012) notes, in physics, abstract constructs and equations are dense and generalised (strong SD), and since they are generalised, they are context-independent (weak SG). In other words, in physics, stronger SD is related to weaker SG and vice versa.

### 3.6.4 Semantic profiles

In order to visualise the relative strengths of SG and SD over time, Maton has developed an analytical method of *semantic profiling*. This indicates how the strengths of SG and SD vary over time. He defines the *semantic range* as the range of the SG and SD between their highest and lowest strengths (Maton, 2013). Figure 3.2 is Maton's illustration of three distinct profiles. The respective strengths of SG and SD are represented on the y-axis and time on the x-axis. It is important to note that the grain-size of analysis may vary in time (in other words, it may cover a short classroom episode, a student task, an entire lecture, or a whole curriculum). Figure 3.2 shows a 'high semantic flatline' (A1), a 'low semantic flatline' (A2) and a 'semantic wave' (B). The semantic range is indicated on the right hand side; A1 and A2 have lower semantic ranges than B (Key: + = stronger; - = weaker).



**Figure 3.2: Illustrative semantic profiles and semantic ranges (Maton, 2013: p. 15)**

Maton defines semantic waves as 'recurrent shifts in context-dependence and condensation of meaning' (2014c: p. 181). He argues that this ongoing 'strengthening'

and ‘weakening’ of SG and SD is crucial for cumulative learning (Maton, 2011: p. 66): ‘... research suggests that key characteristics of knowledge-building and achievement are *semantic waves*’ (Maton, 2014c: p. 181).

Maton’s analysis of classroom practices identifies a particular profile, comprising a series of downward semantic shifts, where the teacher repeatedly ‘unpacks’ and simplifies technical concepts and relates these to everyday examples. He terms this a ‘*down escalator*’ profile because the teacher never models the process of shifting upward, through condensing meaning into technical terms or relating concrete, everyday examples to abstract theoretical ideas (Maton, 2013: p. 17). In contrast, Shay and Steyn (2015) describe the opposite phenomenon, where theorising is emphasised, and applications are used to build towards theory; they refer to this as ‘*upshifting*’. Maton argues that ‘not only the downshifting but also the upshifting from plain, contextualised meanings towards more condensed, decontextualised meanings’ (Maton, 2014c: p. 192) is key for cumulative learning. He also argues that pedagogical practice should entail both ‘downshifting’ and ‘upshifting’ in ‘unpacking’ and ‘repacking’ the concepts, and that it should also relate ‘technical’ concepts to ‘everyday examples’ and condense meaning within abstract theoretical ideas (Maton, 2013: p. 17; Maton, 2014c: p. 192).

Maton notes the discipline-specific nature of semantic waves, and points out that downshifting and upshifting must entail ‘correct’ discipline knowledge. He terms this the *semantic threshold* (Maton, 2013: p. 25). For this reason, analysis of semantic waves in educational practices requires disciplinary expertise.

A good example of analysis using semantic profiling in undergraduate physics is the work by Lindstrøm (2010). She extends Maton’s method of semantic profiling by characterising the strength of SG in terms of a framework of four ordinal categories of SG. She analyses a physics lecture in relation to SG at the level of each sentence spoken. The four ordinal categories of SG are:

- **Concrete** sentences (C) are concrete examples, not specifically related to any abstract concepts;
- **Linked** sentences (L) link something concrete with something abstract;

- **Abstract** sentences (A) contain knowledge purely at the abstract level;
- **Super abstract** sentences (A+) refer to sentences containing concepts that will be explained through a previously introduced abstract concept, with which the students should be familiar (Lindstrøm, 2012).

Each sentence spoken in the lecture is analysed in terms of these four SG categories and represented by a data point on a graph. The graph she constructs thus illustrates a semantic gravity wave, with upshifting and downshifting. As the lecture proceeds, the graph shows that the average level of SG increases. She notes that it is this constant movement up and down the semantic gravity continuum that most likely helps the students in the cumulative knowledge-building exercise that is learning physics (Lindstrøm, 2010).

Another physics study using Semantics is that of Georgiou et al. (2014), who looked at students' responses to a thermodynamics question posed by the lecturer. This study characterises three relative strengths of SG:

- the *weakest semantic gravity level* – containing general principles;
- the *strongest semantic gravity level* – containing descriptions of objects in the question posed;
- the *intermediate level* – containing student reasoning, which 'often linked knowledge claims with weaker semantic gravity to those with stronger semantic gravity' (Georgiou et al., 2014: p. 258).

Unlike in Lindstrøm's (2010, 2012) studies, the analysis in Georgiou et al.'s (2014) study is not in terms of time, but in terms of the semantic ranges exhibited by the different student responses. Both studies develop an external language of description (LoD) in order to apply the concept of SG to the empirical data from their physics contexts. Although labelled differently, both studies introduce an *intermediate (linking) level* of SG to indicate the relative strengths of SG.

### 3.7 Conclusion

This chapter has given an overview of the key sociological concepts, which will be used in the analysis of the data. In particular, I have set out to explain my choice of

the Semantics dimension of LCT as a useful analytical tool to characterise the pedagogical practices and student learning in the context of introductory physics. The next chapter, Chapter 4, will describe the data collection for this study and how the concepts of SG and SD were operationalised in the analysis process.



## **Chapter 4:**

### **Research Methods and Design**

#### **4.1 Introduction**

In Chapters 2 and 3, the theoretical framing of this study was presented. Key concepts for this study from the PER literature include the multiple representations framework (Van Heuvelen, 1991a) and the communicative approaches model (Mortimer & Scott, 2003). From the sociology of knowledge, this study draws on Maton's LCT, in particular, the Semantics dimension, with the key concepts of semantic gravity (SG) and semantic density (SD). This chapter will discuss in detail how these theoretical frameworks and concepts were used to guide the research design, including the gathering and analysis of the data.

#### **4.2 Case study methodology**

Case and Light (2011) argue that methodology is not just 'the methods of data collection and analysis that are used': rather, it is a 'theoretical justification for the use of the methods and the kinds of knowledge that they are able to generate' (p. 205). As Cousin (2009) notes, methods are 'the tools and procedures' researchers 'use for' their 'inquiries', whereas methodology 'is about the framework within which they sit' (Cousin, 2009: p. 6).

The focus of this study was on the pedagogical practices and their influence on student learning in a particular undergraduate physics context. The study, therefore, was not a large-scale quantitative study, but was interpretative in nature, and so the study adopted a qualitative, case study approach. A qualitative study refers to 'any kind of research that produces findings not arrived at by means of statistical procedures or other means of quantification' (Golafshani, 2003: p. 600). Moreover, this study is in the form of words (rather than numbers), gathered by observations and interviews (Zulkardi, 2009). This kind of research 'produces findings that arrived from real-world settings where the phenomenon of interest unfolds naturally' (Golafshani, 2003: p. 600).

Case studies in education research are characterised by in-depth and detailed analysis (Cohen, Manion & Morrison, 2000). As Flyvbjerg (2006) points out, the benefit of using the case study approach is that ‘it can “close in” on real-life situations and test views directly in relation to phenomena as they unfold in practice’ (p. 225). This is why this approach was chosen for this particular study. Yet, many education researchers have also challenged the use of the case study, arguing that it is limited, in the sense that one cannot generalise or arrive at a general conclusion by using only one case. This critique of case study research is dealt with further in Section 4.7 below, where the issue of transferability is discussed. The following section shows how the study has followed such a case study approach.

### **4.3 A case study of two undergraduate physics courses**

As noted in Chapter 1, the context of this study is a university physics department with a sustained history of commitment to undergraduate teaching and learning. The study examines two first year physics courses – the Mainstream course and an Extended course. Both are taught by experienced, well-regarded and dedicated lecturers. In Flyvbjerg’s typology of case-study types, this could be viewed as a ‘paradigmatic case’ (Flyvbjerg, 2001), in that the conditions are conducive for teaching.

As pointed out earlier, it is important to note here that the study is not merely a simple comparison of the two courses. The Mainstream course is used as a benchmark of typical first year physics teaching, in the context of a department that values good teaching. The study examines the affordances of the Extended course, and whether the extra time allows for different pedagogical practices and student learning outcomes, in relation to the Mainstream course benchmark.

As noted in Chapter 3, introductory physics courses the world over cover a very similar set of topics in a particular order. The curricula of the Mainstream and Extended courses are almost identical, but the order of the topics is slightly different. Bernstein (2000) terms this ‘sequencing’. The Extended course curriculum differs somewhat from the Mainstream physics curriculum structure, which starts with mechanics, followed by vibrations and waves, then electricity and magnetism. The



Extended course curriculum starts with a section on the nature of science, followed by a broad, conceptual introduction to modern physics, which includes atomic structure, and nuclear physics. Only then, three months into the course, does the focus turn to mechanics. (The second year of the Extended programme, then, deals with the remaining sections on vibrations and waves, and electricity and magnetism).

The pacing (Bernstein, 2000) of the two courses is also different. In the Extended course, students do first year physics over two years, and so there is much more time for building the foundations for learning and addressing students' difficulties (Herbert et al., 2010; Lesia, Marshall & Schroeder, 2007). More details of these courses will be discussed in Chapter 5, which looks at the introductory physics context at UWC.

#### **4.4 Research methods**

Maxwell (1998: p. 216) defines *research methods* in terms of the following questions: '1. What will you actually do in conducting this study? 2. What approaches and techniques will you use to collect and analyze your data, and how do these constitute an integrated strategy?' Therefore, the following section provides an overview of the data gathering activities as well as details of how the data was analysed.

As mentioned earlier (see Section 1.5), the two research questions for this study are:

1. What is the nature of the Mainstream and Extended pedagogical practices in terms of their semantic profiles (i.e. semantic gravity and semantic density)?
2. What is the correspondence between the pedagogical practices and the ways in which the students approach physics tasks in the Mainstream and Extended Physics courses?

Each of these two research questions required a specific approach to data gathering and analysis. Table 4.1 (below) provides an overview of the research questions, and the methods of data collection and data analysis used to address these. More details about the data gathering and analysis are presented in the section below the table.

**Table 4.1 Overview of research questions, methods of data gathering and analytical tools**

| <b>Research question</b>  | <b>Data gathering</b>  | <b>Analytical tools</b>  |
|---|--|--|
| 1. What is the nature of the Mainstream and Extended pedagogical practices in terms of their semantic profiles (i.e. semantic gravity and semantic density)?              | Field notes and video data of the Mainstream and Extended lectures:  |  |
|   | <u>Lecture sequence 1 &amp; 2:</u><br>Video data of selected lecture sequences* – two from the Mainstream and two from the Extended courses  | <u>Lecture sequence 1 &amp; 2:</u><br>Develop an external language of description (LoD) to carry out a SG and SD analysis in the context of physics pedagogical practices.<br><br>Analyse the pedagogical practices in terms of the LoD.<br><br>Summary of analysis in the form of a <i>semantic profile</i> for the Mainstream and Extended lecture sequences.  |
|   | <u>Lecture sequence 3:</u><br>Video data of one selected lecture sequence from the Mainstream and the Extended courses – how a physics task is dealt with in class                                 | <u>Lecture sequence 3:</u><br>Develop an external LoD for SG and SD in the context of how a physics task (in mechanics) is approached generally.<br><br>Analyse the problem with the use of the LoD – look at how lecturers of the Mainstream and the Extended courses approach the task.<br><br>Summary of analysis in the form of a <i>semantic profile</i> showing how a physics task is dealt with in the Mainstream and Extended courses. |
| 2. What is the correspondence between the pedagogical practices and the ways in which the students approach physics tasks in the Mainstream and Extended Physics courses? | Field notes and video data of students working on a physics task in small groups (four groups – 2 Mainstream; 2 Extended)<br><br>Interviews with the students about their engagement with the task | Use the external LoD for SG and SD (developed in lecture sequence 3) in the context of students tackling physics tasks.<br><br>Analyse the students' approach to the physics task in terms of the LoD.<br><br>Summary of analysis in the form of a <i>semantic profile</i> for Mainstream and Extended groups.   |

(\*lecture sequence means one or two lectures depending on the topic covered)

## 4.5 Data gathering

This section describes the forms of data collection for research question 1 (observation of pedagogical practices) and research question 2 (observation of student groups).

### 4.5.1 Observation of pedagogical practices

The main form of data collection was classroom observation. I began my data collection by spending time in each course, observing the teaching and learning activities during lectures in Term 1 of the academic year, and making notes of the ‘salient features’ (Cohen & Manion, 1980: p. 103) of the pedagogical practices. I noted that, at this stage in Term 1, the way of teaching was relatively distinctive within each course and across the topics covered. By Term 2, the students had settled into their university studies, and so I deliberately chose Term 2 for the first detailed data collection.

As noted above, the order of topics was not identical in the two courses, and so different topics are focused on in each course. Nevertheless, since the approach to formulating pedagogical practices within each course seemed to be relatively distinctive across topics, this did not seem to be a shortcoming.

Since the Mainstream course was used as a benchmark of traditional physics teaching, it was important to observe both courses more or less simultaneously. Video recordings of selected lectures and field notes from both courses formed the main source of data relating to pedagogical practices. As Table 4.2 (below) shows, *lecture sequence 1* consists of lectures, which occurred *at the same time* during the academic year (both during Term 2); at this point, the Extended course was dealing with Position and Displacement, while the Mainstream course was dealing with Work-Energy. In both courses, the lectures observed were introductory lectures on a new topic.

In *lecture sequence 2*, the focus was on observing pedagogical practices when *similar content knowledge* was being taught – Work-Energy (i.e. the continuation of this topic) in the Mainstream course in Term 2 and Work-Energy (i.e. both the start and

the continuation of this topic) in the Extended course in Term 4. In both courses, this was towards the end of the Mechanics section.

In *lecture sequence 3*, the focus was more specific – on how a *physics task* (involving Newton’s 2<sup>nd</sup> Law) was dealt with in the lecture. The topic of Newton’s 2<sup>nd</sup> Law was chosen, because it was the framing concept of the tasks that students were observed to be working on (discussed in Section 4.5.2 below). Since Newton’s 2<sup>nd</sup> Law had already been dealt with in both courses by this stage in the year, I was interested to look at instances where the lecturer was applying Newton’s 2<sup>nd</sup> Law in the context of another topic – Work-Energy in the Mainstream course and Newton’s 3<sup>rd</sup> Law in the Extended course (see Table 4.2). This data enabled me to address Research Question 2 (the correspondence between how tasks are dealt with in lectures and how students tackle physics tasks).

**Table 4.2: Summary of the data relating to classroom observations in both courses**

| <b>Focus of the observation</b>                        | <b>Mainstream course</b>  | <b>Extended course</b>   |
|--|---|--|
| Observed pedagogical practices in terms of SG and SD   | <i>Lecture sequence 1: Same time during the academic year</i>             |  |
|  | Work-Energy (Term 2 – one lecture)  | Position and displacement (Term 2 – two lectures)  |
|  | <i>Lecture sequence 2: Similar content knowledge</i>                      |  |
|  | Work-Energy (Term 2 – one lecture)  | Work-Energy (Term 4 – two lectures)  |
| How a physics task is dealt with in terms of SG and SD | <i>Lecture sequence 3: Dealing with a physics task</i>                    |  |
|  | Newton’s 2 <sup>nd</sup> Law applied in a lecture on Work-Energy (Term 2) | Newton’s 2 <sup>nd</sup> Law applied in a lecture on Newton’s 3 <sup>rd</sup> Law (Term 3) |

Since my classroom observations took place over an extended period of time, I was able to develop a more ‘intimate and informal relationship’ with both the lecturers and the students (Cohen & Manion, 1980: p. 104). This gave me a better chance to discuss pedagogical practices with lecturers and students, and gain insights into these. I was accepted as an insider by them, rather than being seen as a complete outsider

(Creswell, 1998). The relationship that was developed with the lecturers and the students in this way was helpful for the later stage in my research (observing how students engage with a physics task). This relationship moreover enabled me to gain access to the students for small-group interviews, and enabled the students to feel comfortable with me, both when I was observing them working on a physics task and when I was interviewing them.

#### *4.5.2 Observation of student groups tackling a Newton 2<sup>nd</sup> Law physics task*

This part of the study addressed Research Question 2: What is the correspondence between the pedagogical practices and the ways in which the students approach physics tasks in the Mainstream and Extended Physics courses?

Two groups of students from each course were observed working on a particular physics task (These students had volunteered to be part of the study and were keen, above average students). The students themselves chose who to work with in a group of either three or four members. As mentioned above, with regard to the observation of the pedagogical practice, I had to gain access to these students. I therefore let them work in this way, since I wanted the environment to be as conducive as possible for me to listen carefully to their discussions and pick up on their levels of understanding and the difficulties they were experiencing in tackling the task. For ease of reading, each student was given his/her own task sheet, but they were expected to work collaboratively. The task was drawn from a test, which the students had written a few months earlier; since I was interested in the way in which they had tackled the task, rather than just whether they could reach the correct answer, I permitted them to refer to their test scripts, if they felt they were stuck when tackling the task.

The group recorded how they tackled the task on newsprint sheets provided. At times, when there was dissent in the group, individual students would write on their own task sheet provided. The groups' discussions on how they tackled the task were video recorded. This data showed how students approached the task, the different representations they used, and how they were engaged with the task.

After the students had tackled the task, I interviewed them, using a set of interview questions based on the particular task. The working notes on the newsprint were a helpful artefact for ‘stimulated recall’ (Calderhead (1981) of their thought processes. The interview was in a form of a group discussion, where any student from the group could interject, or elaborate on one another’s opinion. They were allowed to respond to the questions randomly, as they wanted.

## 4.6 Data analysis

This section describes the analysis of data for research questions 1 and 2. The process of data reduction is first described, followed by a description of how the concepts of SG and SD are operationalized through the development of two external languages of description

### 4.6.1 Data reduction

As noted above, data was gathered from observations of the pedagogical practices employed in the selected lectures in the Mainstream and Extended courses, as well as from observations of students tackling a particular physics task. The data was in the form of video recordings and field notes. All participants agreed to be recorded. In safeguarding participants’ confidentiality, as per the agreements with them, the recordings were downloaded into a secure place. In analysing this data, I transcribed all the recordings – the verbal and audio data as well as the visual data (gestures used, writing on the board or newsprint sheets, etc.). As a form of ‘data reduction’ (Miles & Huberman, 1994: p. 10), I then prepared summaries of the transcriptions.

With regard to the *observations of lecture sequences 1 and 2*, this involved summarising the way in which the lecture proceeded; in other words, which concepts were dealt with when, and how these were dealt with, including examples used during the lecture, and the level of student engagement during the lecture. For analytical purposes, I then broke up the lecture summary into parts, based on how the *physics knowledge* was being dealt with, in other words, when a new sub-topic was introduced or when the lecturer seemed to shift between abstract theoretical concepts and concrete examples. The summaries also include some verbatim extracts from lecturers’ and students’ speeches, as well as sketches, diagrams, symbols and

equations. Finally, I developed summary tables, which contain details of what occurred during each part of the lecture and what was written on the board, as well as my coding comments.

*For the observation of lecture sequence 3 and students tackling a physics problem task*, I created similar summaries, which captured how the lecturers and students used representations to deal with Newton's 2<sup>nd</sup> Law physics task. The summaries were broken into parts, based on when a new representation was used. These summaries were then also converted into data summary tables.

In order to analyse my data in terms of SG and SD, I needed to operationalize these constructs for the physics context of my study; developing a suitable external LoD would enable me to relate the theoretical concepts of SG and SD to my data.

#### *4.6.2 Developing an external language of description (LoD) to carry out the semantic gravity and semantic density analysis*

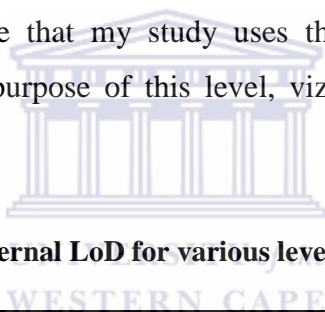
Bernstein (2000) introduced the notion of 'languages of description' (LoDs) as a way of understanding the form taken by theories. He makes the distinction between internal (L1) and external (L2) languages, where L1 'refers to the syntax whereby a conceptual language is created', and L2 'refers to the syntax whereby the internal language can describe something other than itself' (Bernstein, 2000: p. 132). In other words, the external LoD (L2) offers a way of translating between concepts and the empirical data, in order to show how the concepts are utilized for the particular object of study or research context. Chen (2010) notes, furthermore, that 'the development of such an analytic device allows new or unexpected information to emerge from the data, thereby preventing a theory being imposed on data' (p. 77).

In operationalising the constructs of SG and SD for the context of my study, I needed to develop two distinct external languages of description (LoD):

1. A LoD for analysing pedagogical practices in physics (LoD 1)
2. A LoD for analysing how lecturers and students dealt with physics tasks (LoD 2).

4.6.2.1 An external language of description for analysing pedagogical practices in Physics (LoD 1)

In developing an external LoD, I drew on some previous studies in physics contexts. As noted in Chapter 3, Lindstrøm (2010; 2012) and Georgiou (2012) have presented a way of coding the relative strengths of SG on several levels. They have termed these coding characterisations *abstract*, *intermediate (or linking)* and *concrete*. They use *abstract* to refer to statements of general principles or laws, which are used to justify reasoning; *concrete* refers to description of characteristics of objects; and *intermediate/linking* refers to instances where abstract and concrete constructs are linked. Lindstrøm (2010; 2012) used these three levels to characterise the semantic shifts in a lecture on Momentum; Georgiou (2012) used these to analyse students' responses to a physics thermodynamics question. Table 4.3 below describes the external LoD for SG and SD that was used in my study to characterise the semantic profiles of the lectures. Note that my study uses the term 'Linking' rather than 'Intermediate', to show the purpose of this level, viz. of connecting Concrete and Abstract.



**Table 4.3: External LoD for various levels of Semantics**

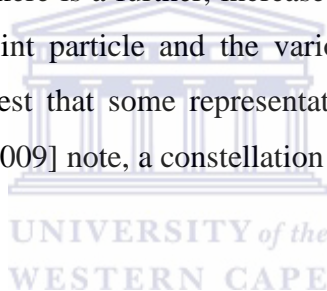
| Strength | SG                                      |                             | SD   | Strength |
|----------|---|-----------------------------|--|----------|
| SG-      | New concepts                            | Abstract<br>A               | Representations (or nominalisations)           | SD+      |
|          | Familiar concepts used in a linking way | Linking (Intermediate)<br>L | Unpacking repacking representations or         |          |
| SG+      | Concrete/real-life situations           | Concrete<br>C               | Linking representations to concrete situations | SD-      |

The strengths of SG and SD were characterised as either *Concrete* or *Linking* or *Abstract*, depending on the lecturer's actions and his/her way of unfolding the



concepts. In terms of **semantic gravity**, strong SG was described as *Concrete*; here, the lecturer was referring to physics concepts or principles in terms of using a concrete/real-life situation or demonstration in class; weak SG was described as *Abstract*, if the lecturer was using new physics concepts or principles; SG was described as *Linking*, if the lecturer was building on familiar concepts or principles in a linking way, between *Concrete* and *Abstract*.

As noted above, **semantic density** (SD) in physics is characterized by the extent of the condensation of meaning within representations (verbal, pictorial, physical, mathematical, etc.). Some physics representations can have meaning more densely inscribed in them than others. For example, a verbal representation of a person pushing a box across the floor could be regarded as less dense than a sketch (pictorial representation) of the situation. When the sketch is converted into a physical representation (e.g. a FBD), there is a further, increased condensation of meaning, as the box is modelled as a point particle and the various forces are represented by vectors. (This is not to suggest that some representations are more important than others; as Airey and Linder [2009] note, a constellation of representations is necessary for physics understanding).



For this study, weak SD corresponded to the *Concrete* level, if concrete situations were represented verbally; *Linking* was relevant if a dense representation was being unpacked or repacked into its constituent parts or meaning (often through the use of a pictorial representation); and *Abstract* was applicable, if a range of meanings was being condensed into a mathematical, physical or graphical representation. (The black and grey arrows indicate the strength in various moves/shifts from either *Abstract* to *Linking* and to *Concrete* or vice versa).

As an illustration of this coding, Table 4.4 gives an example of operationalizing the external LoD for shifts in SD. The examples used are from a lecture on the vector representation of position and displacement.

**Table 4.4. External LoD for shifts in semantic density (SD)**

|                     | (SD+ to SD-) Weakening SD<br>(Moving from Abstract to Linking)   | (SD- to SD+) Strengthening SD<br>(Moving from Linking to Abstract)   |
|---------------------|--|--|
| <b>Example</b>      | The lecturer <i>unpacks</i> the (dense) representation of a vector into its constituent parts or meaning:  | The lecturer <i>condenses</i> the verbal definition of a new concept – ‘displacement’ – into a symbolic representation:  |
| <b>Data extract</b> | The lecturer points to the vector representation on the board: ‘The vector as an arrow has important information... The <i>line segment</i> has half of the information about the vector, in other words, the magnitude only. The <i>head of the arrow</i> shows the direction of the vector.’ | The lecturer refers to a vector diagram on the board and notes: ‘Displacement is the change of position from the initial position to the final position’.<br>He then condenses this verbal definition into symbolic form:<br>‘We can write this as<br>$\Delta\vec{r}_{01} = \vec{r}_1 - \vec{r}_0$ ’ |

As noted in Chapter 3, in the disciplinary context of physics, SG and SD are closely (usually inversely) related. As SG is *weakened*, SD is *strengthened*, and vice versa. In the example in Table 4.4 above, the lecturer weakens SG as he moves from a familiar concept – position as a vector – to a new, more abstract concept – viz. displacement as the difference between two position vectors. An example of *strengthening* SG would be if a lecturer were to introduce the abstract physics concept of ‘work done’, and then move to a concrete demonstration of pushing a box across the floor.

#### 4.6.2.2 An external language of description for analysing physics problem tasks (LoD 2)

As I argued earlier, the concepts of SG and SD from LCT (Maton, 2009) are one of the most appropriate tools available for describing and analysing the kind of teaching and learning situations that underpin this study. These tools were adopted, adapted and combined with existing frameworks of how physics problem tasks are generally dealt with (i.e. Knight, 2007 and Van Heuvelen, 1991a), as discussed in the Literature

Review in Chapter 2. This process of adapting existing frameworks and using these in combination with the concepts of SG and SD is also common in other LCT studies. For example, Maton (2009: pp. 48-49) adapted the ‘coding scheme’ of the relative strengths of SG from Allen’s (1995) use of frameworks for classifying students’ reflective essay writing. He maps SG onto Allen’s framework as follows:

‘Reproductive description’ (e.g. direct quotation from the cases) embodies the strongest semantic gravity – meanings are locked into the context of the case from which the quote is taken. ‘Abstraction’ embodies the weakest semantic gravity: meanings are decontextualised from the specific case to create abstract principles for use in other potential contexts (Maton, 2009: p. 49).

Similarly, Lindstrøm (2010, 2012) used Bloom’s revised taxonomy to look at how the hierarchical knowledge structure of physics is expressed in Link Maps. She used this tool to operationalize and to characterize hierarchical classifications (Factual, Conceptual, Procedural and Metacognitive) that range from concrete to abstract and that match with the continua of SG and SD.

In the context of journalism studies, Kilpert and Shay similarly modified Maton’s (2009) adaption of Bennett’s (2002) research with Bloom’s revised taxonomy to develop ‘a continuum for measuring semantic gravity’ (Kilpert & Shay, 2013: p. 8) in the analysis of student assessments. The modifications they made to Bloom’s taxonomy reflected the specific nature of journalism (with its theory and practical aspects), with categories ‘ranked from stronger to weaker semantic gravity’ (Kilpert & Shay, 2013: p. 8).

In summary, then, these other LCT studies have all adapted existing frameworks and used these in combination with SG and SD. In this study, frameworks on physics representations (Knight, 2007; Van Heuvelen, 1991a) are used in relation to SG and SD when dealing with physics tasks. To create the possibility for students to learn physics in the way that it is practiced by physicists, students need to become competent in moving ‘back and forth’ (Knight, 2007; Van Heuvelen & Zou, 2001) between multiple representations (i.e. between verbal, pictorial, physical, mathematical and graphical representations). As argued by Rosengrant et al. (2009), if students are expected to learn to use representations, then moving between different

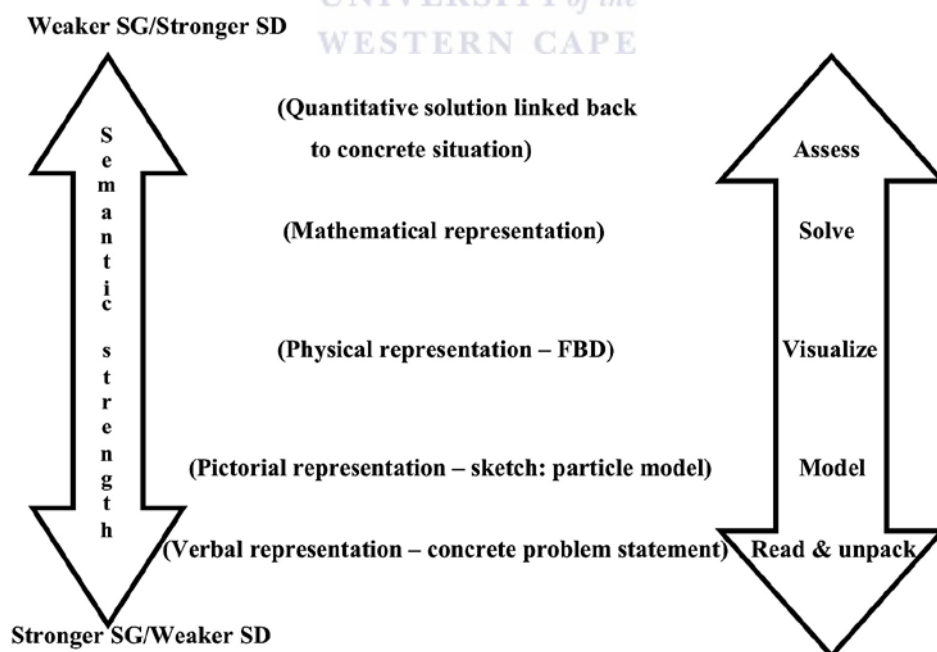
forms of representation has to be the link between the abstract and concrete ways of explaining physics. This part of my analysis involves the processes of moving between these abstract and concrete constructs for dealing with physics tasks competently. Table 4.5 and Figure 4.1 below capture what is expected in physics education in order for students to move ‘back and forth’ between multiple representations (cf. Knight, 2007; Van Heuvelen, 1991a).

**Table 4.5: Framework of representations to be used in tackling a mechanics problem**  
(based on Knight, 2007 and Van Heuvelen, 1991a)

| <b>Multiple Representations</b>  |  |
|--|--|
| <p><b>Verbal representation</b> (written or words)</p> <ul style="list-style-type: none"> <li>• read the problem carefully</li> <li>• sketch the situation</li> <li>• identify the object of interest (the system)</li> <li>• draw a circle around the object of interest</li> <li>• identify the external objects or forces interacting with the system</li> </ul>  | <p><i>Reading</i> and <i>unpacking</i> the problem.</p>  |
| <p><b>Pictorial representation</b> (particle model)</p> <ul style="list-style-type: none"> <li>• represent the object as a point particle</li> <li>• make simplifying assumption when interpreting the problem statement</li> </ul>  | <p><i>Modeling</i> the situation to capture the important features of the problem.</p>   |
| <p><b>Physical representation</b> (Free Body Diagram - FBD)</p> <ul style="list-style-type: none"> <li>• identify all the forces acting on the object</li> <li>• establish a coordinate system to identify signs</li> <li>• represent the object as a dot at the origin of the coordinate axes – particle model</li> <li>• translate on the FBD the components for an inclined surface</li> <li>• draw force vectors representing all the</li> </ul> | <p><i>Visualize</i> the problem with important aspects of physics and evaluate the information that has been given. (This is a process of translating words into symbols).</p> |

|  |   |
|--|---|
| <p>identified forces (lengths represent the relative magnitudes)</p> <ul style="list-style-type: none"> <li>• label all the forces in the diagram (with two subscripts)</li> <li>• draw and label the vector <math>F_{\text{net}}</math> or the acceleration of the motion</li> <li>• translate the problem into symbols (define symbols for masses and for the interaction)</li> <li>• identify the desired unknowns</li> </ul>   |   |
| <p><b>Mathematical/quantitative representation</b><br/>(Newton Second Law)</p> <ul style="list-style-type: none"> <li>• identify the law (first write the required law/equations for calculating the unknowns)</li> <li>• find <math>F_{\text{net}}</math> for the parallel sides and the perpendicular sides (the components for the inclined surface should be included in these sides)</li> <li>• use explicit subscripts throughout this representation, each referring to a symbol that was defined in the physical representation/FBD</li> <li>• replace the symbols with numerical values defined in the physical representation</li> </ul> | <p><u>Solve</u> the problem by identifying appropriate laws in answering the questions and decide which mathematical representations have to be used. Only after modeling/FBD and visualization are complete is it time to develop a mathematical representation with specific equations that must be solved.</p> |
| <ul style="list-style-type: none"> <li>• check whether the result is reasonable</li> <li>• provide a final concluding statement wherein you interpret mathematics solution in the context of the problem</li> <li>• check whether the result has correct proper signs and units</li> </ul>   | <p><u>Assess</u> the problem, not to prove that the answer is right but to rule out answers with a little thought.</p>  |

Figure 4.1 below shows the relationship between Semantics and the framework for multiple representations used in tackling mechanics problem tasks (from Table 4.5). It provides an external LoD for analysing physics problem tasks, which relates the physics representations onto a semantic continuum. At the bottom of the semantic continuum is the verbal representation of the concrete task situation, then moving up the continuum, the representations become semantically denser and more abstracted from the specifics of the problem context (weaker semantic gravity). At the top of the semantic continuum is the ‘assess’ stage – when the quantitative solution is linked back to the concrete situation. The placing of ‘assess’ on the semantic continuum was challenging, since it entails a movement *between representations* from an abstracted mathematical representation (weaker semantic gravity) back down to a concrete context (stronger semantic gravity). Since its starting point is an intention to critically review the mathematical representation, I have chosen to place it at the top of the continuum, with a clear note that ‘assess’ signals a return from a quantitative representation to a concrete, qualitative representation. In the semantic profiles in Chapters 8 and 9, this movement back down to the concrete context is clearly indicated (see Figures 8.1, 8.2, 9.1 to 9.4).



**Figure 4.1: Semantic gravity and semantic density in relation to multiple representations in physics tasks**

#### 4.6.3 *Creating a semantic profile in terms of semantic gravity and semantic density*

As noted in Chapter 3, in order to visualise the relative strengths of SG and SD over time, Maton (2013) has developed the analytical method of *semantic profiling*. It is important to note that this study presents two different forms of semantic profiles:

1. A profile that maps how the strengths of SG and SD vary over time in lecture sequences, and
2. A profile that maps how the strengths of SG and SD vary as lecturers and students use various representations in dealing with physics tasks.

##### 4.6.3.1 *Semantic profiles for pedagogical practice*

Once the lecture summary had been broken up into parts for analytical purposes, the parts (and sub-parts) of the lecture were coded in terms of the external LoD for SG and SD (see Table 4.3 above). The coded parts together form a semantic profile, with the semantic levels of Concrete, Linking and Abstract on the vertical axis of the semantic profile figure. The shape of the profile is an indication of how the transitions take place between the semantic levels (whether quickly or gradually). In the case, where there is no explicit connection between levels (for example, the lecture jumps to a new concept without a link to any previous concepts), this is shown as a discontinuity. In the case, where no transition is taking place for an extended period of time, the semantic profile is shown as a ‘semantic flatline’ (Maton, 2013: p. 15).

It should be noted that an alternative way of representing the semantic shifts would have been to represent the coding of each lecture part (and sub-part) as a point on a graph. This is how Lindstrøm (2012) represents the semantic shifts in her analysis of a lecture on momentum. However, the grain size of her analytical units is different – she codes each sentence in the lecture as Concrete, Linking and Abstract, whereas in this study, the grain size is larger – I code each part or sub-part of the lecture.

The usefulness of the semantic profile approach is that it provides a helpful way of visualizing the shifts in SG and SD during a lecture, how these take place over time (i.e. rapidly or gradually) and the frequency at which these occur in a lecture (i.e. whether they are spread out or compressed). The time spent at each level is indicated on the horizontal axis of the semantic profile figure. Coding is used to indicate who is

involved in the shifts between the semantic levels. As noted in Chapter 2, the modes of interaction in a lecture can be characterised as *non-interactive* (when the lecturer talks) or *interactive* (when the lecturer and students engage). Non-interactive communicative approaches are indicated with a *thin line*; interaction (when the students are also engaged in the shifts) is indicated with a *thick line*.

#### 4.6.3.2 *Semantic profiles for the physics problem tasks*

Once summaries had been made of how the lecturers or students used representations to deal with the physics task, the summary was broken up into parts for analytical purposes, and the parts were coded in terms of the external LoD for SG and SD (see Figure 4.1 above). The coded parts together form a semantic profile, with the representations ranging from Verbal (read and unpack) to Mathematical (solve and assess) on the vertical axis of the semantic profile figure. The shape of the profile gives an indication of how rapidly the transitions take place between representations (whether quickly or gradually).

## 4.7 **Validity and reliability**

Notions of validity and reliability have their origins in quantitative research and these need to be conceptualized in different ways for qualitative research (Lincoln & Guba, 1985; Merriam, 1988). Lincoln and Guba (1985) assert that the trustworthiness of a qualitative research study involves establishing its credibility, transferability, dependability and confirmability.

Consequently, with regard to the first concept introduced by Lincoln and Guba (1985), viz. *credibility*, when the researcher conducts a research study, s/he should ask him/herself whether the findings of the study make sense and whether the results are *credible* enough to the people they study and the readers (Miles & Huberman, 1994). The researcher should see *validity* as *authenticity*, where s/he should look for an authentic portrait in his/her research (Miles & Huberman, 1994). Lincoln and Guba put forward several techniques for ensuring the credibility of research findings. These include what they term prolonged engagement, persistent observation, triangulation and peer debriefing (Lincoln & Guba, 1985).



As noted earlier, my fieldwork entailed prolonged engagement: I attended and observed many lectures and tutorials during the academic year. Because the observations took place over an extended period of time, I was able to develop a more ‘intimate and informal relationship’ with the students, which enabled me to have a better insight into their behaviour (Cohen & Manion, 1980: p. 104), and to make them feel at ease when interviewing them.

*Triangulation* was used in the data gathered on how students tackled physics tasks: students were video-recorded while tackling a physics task and then interviewed after finishing the task. *Triangulation* was used to evaluate the same objects from different perspectives that were provided by the different methods used (Nieman, Nieman, Brazelle, Van Staden, Heyns & De Wet, 2000).

The final technique for ensuring credibility is what Lincoln and Guba (1985) term ‘peer debriefing’. I presented parts of this research at national seminars and at three international conferences, viz. the 7<sup>th</sup> Basil Bernstein conference (BB7), the 7<sup>th</sup> Higher Education Close-Up conference (HECU7) and the 1<sup>st</sup> Legitimation Code Theory conference (LCT1). This enabled me to get feedback from education, sociology and Science, Technology, Engineering and Mathematics (STEM) colleagues who were working with similar analytical constructs. I also exposed this study to critique from three peer groups for feedback: the first group was my departmental colleagues, the second and the third were my research groups – CREE (Centre for Research in Engineering Education) and Sasol Inzalo. These research groups consist of STEM researchers who are engaged in teaching and learning, as well as research, both in schools and at higher education institutions. Furthermore, I had formal meetings with three international experts in the fields of LCT and physics education for further comments, especially with regard to the coding in SG and SD. The feedback from all these specialists helped me to improve and create an in-depth interpretation of the external LoD and also to modify the coding system appropriately.

The second concept that Lincoln and Guba (1985) introduce is ‘transferability’ – the process of showing that the findings in a study have applicability in other contexts. Here, the provision of a ‘thick description’ of research (Geertz, 1973) is important as

a way of enabling others to judge the results and their usefulness in other situations. This study has described and produced a rich, *thick description* of the physics undergraduate context of the study. This in-depth description could assist other researchers to decide the extent to which the findings from this research might be generalizable to another situation (Cohen et al., 2000).

The third concept proposed by Lincoln and Guba (1985) is ‘dependability’, which involves showing that the findings are consistent and could be repeated. Dependability can be assessed through an audit trail – the preservation of all information regarding the research so that the findings could be verified by independent persons (Nieman et al., 2000). Producing an audit trail is a process in which I as the researcher demonstrate how my work and thinking progressed throughout the project with the use of verifiable documents (Finlay & Ballinger, 2006). In this study, the process of analysis was made transparent through demonstrating (using data summary tables) how observation and interview data was analysed. Further data exemplars are provided in the appendixes.

The fourth concept that Lincoln and Guba (1985) introduce is ‘confirmability’ – a degree of neutrality, which can also be understood as the extent to which the findings of a study are shaped by the respondents and not by researcher bias, motivation, or interest. The audit trail is one means of addressing this: it can help other researchers to ‘follow the actual sequence of how data was collected, processed, condensed/transformed, and displayed’ to draw a specific conclusion (Miles & Huberman, 1994: p. 278). In other words, the outcome of the conclusion must depend on ‘the subject and conditions of the inquiry’ rather than on the researcher as the inquirer (Guba & Lincoln, 1981).

Another way of addressing confirmability is that of researcher reflexivity and positionality. Reflexivity requires that, as a researcher, one makes explicit the possible sources of researcher bias. As noted in Chapter 1, my role was that of academic literacy practitioner within the Extended physics course, and as a researcher I needed as far as possible to guard against bias towards the Extended course in relation to the Mainstream course. This study goes beyond merely being a comparison of the two

courses; rather, the aim was to understand the different affordances for learning that the two curriculum structures could enable.

#### **4.8 Ethical issues**

The appropriate procedures were followed in order to clear the study with the Ethics Committee of the Faculty of Natural Sciences at UWC. Students completed indemnity forms and pseudonyms were used in this study to ensure anonymity. As mentioned before, the students were told at the start of the observations and the interviews that their identity would be protected. In my data, I moreover refer to the students as student 1, 2, 3 etc. Appendix 5 is a blank copy of the indemnity forms completed by the students.

The students, together with the lecturers, were informed about the purpose, nature and duration of the study. However, protecting the identity of the lecturers was more difficult, since there were only two lecturers involved in each of the two courses during the period of the study. In both courses, the lecturers' approaches to teaching the course were similar, and so the study could have been conducted with either of the two lecturers. In both cases, I opted to work with the more senior of the two lecturers.

Through developing a collegial relationship of *trust* with both lecturers prior to collecting data in their lectures, I emphasised to the lecturers involved that the research focus was not on the individual lecturers, but rather on the affordances of different curricula structures. In this way, I aimed to establish that the study would not be setting out to criticize their teaching.

#### **4.9 Conclusion**

This chapter has discussed in detail how theoretical frameworks and concepts drawn from PER (particularly research on multiple representations) and LCT (in particular SG and SD) were used to guide the research design of my study, including the gathering and analysis of the data. The following five chapters (Chapters 5 to 9) present the findings of my study.

## **Chapter 5:**

### **The Introductory Physics Context at UWC**

#### **5.1 Introduction**

Chapter 1 (Section 1.3) and Chapter 4 (Section 4.3) gave a brief overview of the two introductory physics courses that form the setting of this study. This chapter provides more detail on the curriculum structure, the classroom setting and the use of course materials in these two courses – based on extensive classroom observations and analysis of course documentation.

#### **5.2 The curriculum structure**

As noted in Chapter 4, the introductory Extended course differs from the Mainstream course in several aspects. Although the content is almost identical in both courses, the order of the topics is different. Bernstein (2000) terms this ‘sequencing’. The Mainstream physics curriculum structure starts with mechanics, followed by vibrations and waves, before moving on to electricity and magnetism. The Extended curriculum starts with a section on the nature of science, followed by a broad, conceptual introduction to modern physics, which includes atomic structure, and nuclear physics (using the classic textbook, Paul Hewitt’s *Conceptual Physics* [Hewitt, 1998]). Only then, three months into the course, does the focus turn to mechanics (which is the traditional starting point for the first year Physics courses). The second year of the Extended programme, then, deals with the remaining sections on vibrations and waves, and electricity and magnetism. See Table 5.1 for details of the selection and sequencing of topics in the Mainstream and Extended courses (Note: the topic descriptions in Table 5.1 are taken from the course documentation; this study examined only the Mechanics sections [shaded in grey to show the contrast] and the lecture topics analysed in Chapters 6, 7 and 8 are indicated in bold).

**Table 5.1: Selection and sequencing of topics in the Mainstream and Extended courses**

| Mainstream programme   | Extended programme  |
|--|---|
| 1 <sup>st</sup> Year   | 1 <sup>st</sup> Year  |
| Semester 1: Term 1<br>Mechanics <ul style="list-style-type: none"> <li>• Concept of motion</li> <li>• Kinematics in one dimensions</li> <li>• Vectors and coordinate systems</li> <li>• Kinematics in two dimensions</li> <li>• Forces and motion</li> <li>• Dynamics I: Motion along a straight line</li> <li>• Newton's third Law</li> <li>• Dynamics II: Motion in a plane</li> </ul> | Semester 1: Term 1 <ul style="list-style-type: none"> <li>• Course introduction</li> <li>• The nature of science</li> <li>• Atomic nature of matter</li> <li>• Development of models that describe the atoms</li> <li>• The atomic nucleus and radioactivity</li> <li>• Fission and fusion</li> </ul>   |
|  | Mechanics <ul style="list-style-type: none"> <li>• Kinematics I: Describing motion</li> </ul>   |
| Semester 1: Term 2 <ul style="list-style-type: none"> <li>• Impulse and momentum</li> <li>• <b>Energy</b></li> <li>• <b>Work</b></li> <li>• Rotation of a rigid body</li> <li>• Newton's theory of gravity</li> </ul>  | Semester 1: Term 2 <ul style="list-style-type: none"> <li>• <b>Kinematics II: the full description of motion in one &amp; two dimensions</b></li> <li>• Dynamics: applying Newton's Laws of motion to problems in relevant contexts to which students can relate in one &amp; two dimensions (Newton's 1<sup>st</sup> and 2<sup>nd</sup> Laws)</li> </ul> |
| Semester 2: Term 3 <ul style="list-style-type: none"> <li>• Vibrations and waves</li> </ul>  | Semester 2: Term 3 <ul style="list-style-type: none"> <li>• <b>Dynamics (continued): applying Newton's Laws of motion as above (Newton's 3<sup>rd</sup> Law)</b></li> <li>• Conservations laws: Momentum</li> </ul>   |
| Semester 2: Term 4 <ul style="list-style-type: none"> <li>• Electricity and magnetism</li> </ul>   | Semester 2: Term 4 <ul style="list-style-type: none"> <li>• Conservations laws (cont): Momentum</li> <li>• <b>Conservations laws: Energy</b></li> <li>• <b>Work-energy theorem</b></li> </ul>   |

|  |  |
|--|--|
|  | <ul style="list-style-type: none"> <li>• Rotational dynamics</li> </ul>  |
|  |  |
|  | 2 <sup>nd</sup> Year   |
|  | Semester 1: Term 1 <ul style="list-style-type: none"> <li>• Electricity and magnetism</li> </ul>                 |
|  | Semester 1: Term 2 <ul style="list-style-type: none"> <li>• Electricity and magnetism</li> </ul>                 |
|  | Semester 2: Term 3 <ul style="list-style-type: none"> <li>• Vibrations and waves</li> </ul>                      |
|  | Semester 2: Term 4 <ul style="list-style-type: none"> <li>• Capstone section: mathematics for physics</li> </ul> |

Course documentation from the initial design stage of the Extended course (Lesia et al., 2007) indicates that the intention of starting with the nature of science and modern physics is to focus initially on topics not dealt with at school, in order to shift students away from a view of learning physics as merely substituting numbers into equations. In other words, by exposing them to an unfamiliar topic, they are not able to use the learning approaches that had worked at school. Atomic and nuclear physics is also considered as an ideal vehicle to discuss the nature of scientific knowledge and how it builds and develops (for example, the progression of knowledge, as illustrated in the development of various models of the atom). The focus here is on making explicit the hierarchical knowledge structure of physics, as well as the interconnectedness of physics concepts.

The curriculum structure or sequencing of the physics topics is presented to the students differently in the two courses. The Mainstream students are supplied with an information sheet, including of a list of topics to be covered each week, and the dates for tests. In the Extended course, a course reader lists the topics to be dealt with in the course (see Table 5.1 above). See Appendices 1A and 1B for course documentation (Mainstream course information sheet and Extended course reader).

In the Extended course, the curriculum structure is additionally presented by means of a concept map for the course, devised to show the links between the different sections/topics and concepts of the course; this is referred to frequently in classes

during the year, and is used as a sort of ‘roadmap’ for the course – showing students how later topics/concepts are built upon the earlier ones. This is also an attempt to make the hierarchical knowledge structure of physics more apparent to students. See Appendix 1C for the concept map.

The course outlines indicate that the pacing (Bernstein, 2000) of the two courses is also different: essentially, in the Extended course, students do first year physics over two years (see Table 5.1). In the Extended course, moreover, the pacing is slower in the first semester and then picks up in the second semester, especially for the last term of the year (Table 5.1 shows that the pace of the Mechanics section in the Extended course in Term 4 is similar to the pace of that section in the Mainstream course in Term 2 – as indicated by the topics dealt with). The purpose of doing things in this way, as stated in the course documentation, is to prepare the students for the increased pacing and the greater complexity of topics in the second year of the Extended course and the following two years of their BSc degree.

The two courses also differ in terms of *control* over pacing: classroom observations indicated that, in the Mainstream course, the lecturer strongly controls the pacing of the content, whereas in the Extended course, the ‘extended first year’ model gives the lecturer more time to set up in-class activities for students, and to respond to students’ questions and difficulties. In other words, there is more student control of pacing (i.e. in Bernstein terms, a weaker framing of pacing) in the Extended course, as compared to the Mainstream course. The issue of pacing in these two courses is examined in more detail in Chapters 6 to 8.

### **5.3 The classroom setting**

As noted in Chapter 2, Physics Education research (PER) has suggested that teaching Physics using non-traditional instruction methods, specifically those where students are actively involved and engaged, promotes their learning (see, for example, Etkina & Van Heuvelen, 2007; Wieman & Perkins, 2005). The Extended course designers thus concluded that the traditional lecture format and consequently the large lecture theatre setting, would not be optimal. Therefore, a flat-space venue was found and converted to look like a low-technology version of a SCALE-UP (Student-Centered

Active Learning Environment for Undergraduate Programs) classroom. This SCALE-UP approach (Beichner, 2008; Beichner, Bernold, Burniston, Dail, Felder, Gastineau, Gjertsen, & Risley, 1999) promotes interactive engagement (IE) in large classes, in a flat-space venue equipped with educational technology. The UWC Extended course venue is occupied by 10 large workbenches, which are permanently fixed to the floor. The room is used for all class activities, including practical experimental work. Students work in groups of three, with three groups seated around each table. The seating arrangement also allows short presentations to be made at either end of the venue by means of a screen for a data projector at one end and a multimedia monitor with audio-visual equipment at the other. Class discussions are facilitated with the aid of a portable microphone. This arrangement is intended to facilitate one-on-one engagement and interaction, as well as to use the benefits of peer interaction in learning – aligning with co-operative learning principles developed by Johnson and Johnson (1984). Twelve large whiteboards are arranged against the walls between the windows and the back wall to facilitate group interaction and student-lecturer engagement.

The Mainstream course venue, in contrast, is a traditional, tiered lecture theatre, with a large desk at the front and large chalk-boards. This venue allows the lecturer occasionally to engage with the students, though mainly with those in the front row and on the sides of the venue. The weekly tutorials are held in a flat venue, to provide time for students to work on problems and engage with tutors.

In terms of the number of students in each course, the Mainstream course has 60 students and the Extended course has 150 students (approximately 75 in each class, with this study looking at only one of these classes).

#### **5.4 Use of course materials**

Both the Mainstream and Extended courses use the same *textbook* for Mechanics, viz. *Physics for Scientists and Engineers: A strategic approach* by Randall Knight (2007). The textbook is based on PER, and emphasises the importance of conceptual understanding and the use of multiple representations. The aim of the textbook is to help students to understand concepts and communicate their understanding of these



concepts in words, diagrams, graphs and then finally mathematically. These mathematical aspects are introduced as tools in forming, presenting and communicating physics concepts and principles in a concise way and in modelling natural phenomena.

The Extended course students are given a *course reader* at the outset, which provides extensive information about the course philosophy, learning outcomes and assessment modes to be used in the course. It emphasises the use of modelling processes and multiple representations in problem-solving and the importance of understanding physics concepts. At the start of the course, students are given reading tasks that require them to read and engage with the philosophy and expectations of the course, as laid out in the course reader. This is done in the form of an academic literacy exercise, where students are guided in class how to read a text, summarise it and write coherent responses. For each task throughout the year, learning outcomes are written at the top of the exercise, so that students know what they need to achieve or what is expected in that particular task.

The use of *class notes and handouts* is also different in the two courses. In the Mainstream course, the lecturer supports his explanations with diagrams and notes on the board and makes no mention of the textbook, students' notes or class handouts. The class handouts are given to students only after they finish each topic, and students are expected to refer to the course textbook on their own. In the Extended course, students are given summary class notes before starting with each chapter. They are required to complete pre-reading ('warm-up' tasks) prior to the following class, and are also expected to read the chapter in the textbook and submit a chapter summary. The intention of this is to spend more time in class on applying physics principles and addressing students' questions or difficulties arising from the pre-reading tasks.

## **5.5 Concluding remarks**

This chapter has extended the brief overview of the UWC introductory physics context that was provided in Chapters 1 and 4. Based on classroom observations and analysis of course documentation, this chapter has provided more detail on the curriculum structure, the classroom setting and the use of course materials in these

two courses. Although this overview does not specifically address the research questions of the study, it sets the context for the research findings presented in the following four chapters.



## Chapter 6:

# Pedagogical practices: The semantic profiles of Mainstream and Extended Courses – Lecture Sequence 1

### 6.1 Introduction

This chapter presents the analysis of the data relating to Research Question 1: *What is the nature of the pedagogical practices in terms of their semantic profiles (i.e. semantic gravity and semantic density)?* This research question is addressed in the following three chapters (Chapters 6 to 8). As indicated in the Methodology chapter (Chapter 4, Table 4.2), the data analysis of lecture sequences 1 and 2 focuses on lectures from the Mainstream and Extended courses (discussed in Chapters 6 and 7 respectively), whereas the data analysis of lecture sequence 3 specifically examines how problem tasks are dealt with in class (discussed in Chapter 8).

This chapter presents an analysis of lecture sequence 1 from each course, occurring *at the same time* during the academic year (Term 2). As noted in Chapter 5 (see topics highlighted in bold in Table 5.1), at this stage in the academic year, the Mainstream course was dealing with Work-Energy, whereas the Extended course was dealing with the concepts of Position and Displacement. In both cases, the lecture sequences started with the introduction of a new topic.

This chapter will present the analysis of classroom observations in the Mainstream and Extended lectures to characterise the pedagogical practices in terms of SG and SD. As discussed in Chapter 4 (see Section 4.5), the Mainstream lecture is used as a benchmark of typical first year physics teaching. The Extended lecture was observed in the same week as the Mainstream lecture. Both were introductory lectures on a new topic, yet the analysis shows how their associated pedagogical practices are very different. The semantic profiles and the concepts of SG and SD provide a useful way of illustrating how they are different.

This chapter has a strong methodological emphasis: extensive use is made of the data, in order to demonstrate how each lecture sequence is analysed in terms of SG and SD

and to illustrate the analytical process involved in constructing the semantic profiles. This close engagement with the data provides a form of ‘audit trail’ (Guba & Lincoln, 1998) for the reader, which makes transparent the analysis processes, since this form of analysis using semantic profiles is fairly novel. The data tables, viz. Tables 6.1 and 6.2 below, may seem particularly data-rich for the reader, but a summary of each lecture sequence is also provided after each semantic profile (Figure 6.1 and Figure 6.2), to offer the reader a useful overview. The data in these tables also serves to give the reader a ‘thick description’ (Lincoln & Guba, 1985) of the lecture context.

## **6.2 Detailed analysis of lecture sequences from the Mainstream and Extended courses**

As noted in the Methodology chapter (Chapter 4), the construction of summary tables for each lecture sequence amounted to a form of data reduction. These are set out in Tables 6.1 and 6.2. From each summary table, the semantic profile is constructed (for a reminder of how SG and SD are related through an external LoD to the levels of Abstract, Linking and Concrete in a physics context, see Table 4.3 in Chapter 4). After the semantic profiles for the Mainstream and Extended lectures are put forward, their similarities and differences are analysed in Section 6.3.

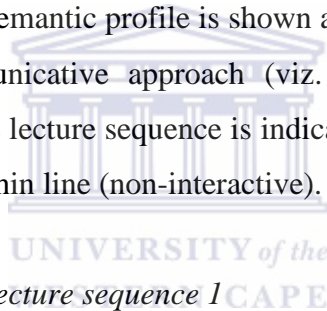
### *6.2.1 How to interpret the data tables and semantic profiles below*

As discussed in the Methodology chapter (Chapter 4), each lecture was broken down into several parts, for analytical purposes. This division was based on when a new sub-topic was introduced or when a shift occurred between abstract theoretical concepts and concrete examples. At times, there were shifts within a part, and these sub-parts are labeled as a, b, c, etc. Each summary table contains the following details about the lecture sequence observed:

- Column 1: the numbered parts of the lecture and the time taken for each part;
- Column 2: a summary of what happened in each part of the lecture (this includes a summary of what was said verbally by the lecturer and students, as well as gestures, demonstrations, and so on);

- Column 3: what was written on the board (words, sketches, diagrams, symbols, equations, etc.);
- Column 4: coding comments, which explain how the parts of the lecture were coded in terms of the external LoD (see Table 4.3 in Chapter 4);
- Column 5: coding in terms of Abstract, Linking and Concrete;
- Column 6: the communicative approach (interactive or non-interactive).


The coding comments in column 4, together with column 5, can be used to interpret the shape of the semantic profile presented below. The shape of the profile is an indication of how the transitions take place between the semantic levels (viz. whether quickly or gradually). Where there is no explicit connection between levels (for example, when the lecturer jumps to a new concept without a link to the previous ones), this is shown as a discontinuity. Where no transition has taken place for an extended period of time, the semantic profile is shown as a ‘semantic flatline’ (Maton, 2013). The form of communicative approach (viz. whether interactive or non-interactive) in each part of the lecture sequence is indicated on the semantic profile by a thick line (interactive) or a thin line (non-interactive).

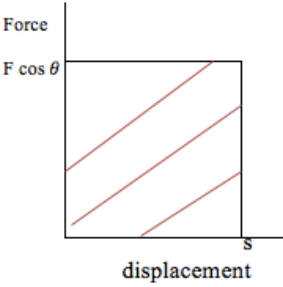
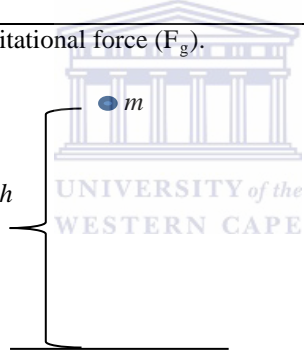


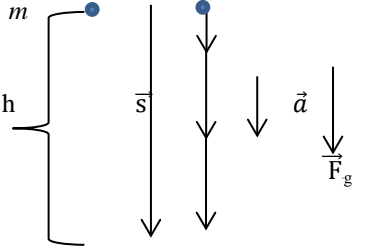
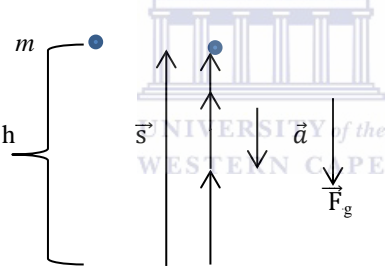
### 6.2.2 Mainstream course: Lecture sequence 1

This section presents an analysis of one 60-minute lecture sequence of the Mainstream course (as shown in Table 6.1 below, the lecture took 56 minutes and the 4 minutes left were used for administrative purposes). Table 6.1 is the summary table containing the data that was used to construct the semantic profile, illustrated in Figure 6.1 below the table.


**Table 6.1: Summary data for Mainstream lecture sequence 1 (Topic: Work-Energy)**


| Parts of the lecture and the time taken (approximate) | What happens in class  | What is written on the board   | Coding comments   | Position and shifts in SG and SD<br>Abstract = A<br>Linking = L<br>Concrete = C | Communicative approach (interactive or non-interactive) |
|---|--|--|---|---|---|
| 1<br><i>1.5 minutes</i>                               | The lecturer starts the lesson by asking the class, ‘If someone asks you, how do you define work, what do you say?’ He then answers the question himself: ‘F dot s’. He then writes symbolically the definition of work on the board:<br>$W_F = \vec{F} \cdot \vec{s}$<br>He draws attention to the subscript $W_F$ and notes that this way of defining work is a shorthand for writing $W_F = F_s \cos \theta$ , where $\theta$ is the angle between the two vectors $\vec{F}$ and $\vec{s}$ .  | $W_F = \vec{F} \cdot \vec{s}$<br><br>$W_F = F_s \cos \theta$<br><br> | SG is strong: The lecturer starts with abstract concept of work, and meaning is condensed in the term ‘work done’. He writes this in dense symbolic representation $W_F = \vec{F} \cdot \vec{s}$ . Therefore, this is coded as the Abstract level (A).<br><br>He elaborates that $\vec{F} \cdot \vec{s}$ can be written as $F_s \cos \theta$ , and so there is a slight shift down in SD.<br><br>Note: as outlined earlier, the shape of the profile is an indication of how quickly the transition took place. | A   | Lecturer only   |
| 2<br><i>0.5 minutes</i>                               | The lecturer illustrates the significance of the angle between $\vec{F}$ and $\vec{s}$ with an example: ‘If you’re carrying something, a bag or a suitcase, the work done by you on the bag is zero, because you are going this way ( <i>indicating to the right</i> ), and of course you apply the force vertically upwards ( <i>showing how to pull the bag upwards</i> )’.<br>The lecturer points out that ‘you were taught at school, work is the force times distance; that is wrong, that is the <i>special case</i> , when work is the force times distance’. |  | Although the lecturer refers to students’ prior knowledge from school, this reference is rapid (approx. 30 seconds) with only a brief further elaboration at this point; he notes that this is a ‘special case’, though without explaining that this special case is when $\cos \theta = 0$ . Therefore this illustrative example is coded as a Linking (L) level.  | A – L   | Lecturer only   |
| 3<br><i>2 minutes</i>                                 | The lecturer then shifts to a different representation: presenting $F_s \cos \theta = W_F$   |  | The lecturer moves from the illustrative example of work done (L level) to a  | L – A – L   | Lecturer only   |


|                      |  |  |  |           |  |
|----------------------|--|--|--|-----------|--|
| 3a                   | graphically, he says, ‘We can very easily find this graphically’, adding, ‘if the force is constant’, and writing on the board $F = \text{constant}$ , before drawing the graph:   | <p><math>F = \text{constant}</math></p>            | graphical representation of the work done. Meaning is again condensed in this representation (coded at A level), but he then unpacks the graphical representation by explaining how to find the work done graphically, and he relates the area under the graph to the symbolic representation: $(F \cos \theta \cdot s = W_F)$ (coded at L level)  |           |  |
| 3b                   | The lecturer shows on the graph how to calculate the area under the graph, that is, $F \cos \theta \cdot s = W_F$ (he shades the area under the force/displacement graph graph, and notes that this area is work done by force).   |  | Note on the semantic profile even though some unpacking is taking place, a significant amount of prior knowledge, understanding and ability to translate between symbolic and graphical representations is being taken for granted here (coded at L level).  |           |  |
| 4<br>9 minutes<br>4a | The lecturer then introduces examples of ‘finding the work done by various forces’; the first example is the work done by the <i>gravitational force</i> ( $F_g$ ). He demonstrates this by throwing a piece of chalk vertically upward, and notes that the chalk returns: this is indicative of the gravitational force acting on that body. He says, ‘Let’s say this body falls, the body has the mass $m$ and falls through a height $h$ ’, and draws a sketch of a body falling downwards. | <p>1. Gravitational force (<math>F_g</math>).</p>  | The lecturer starts with a concrete example, which is demonstrated and described verbally. This is coded at the Concrete (C) level.<br><br>There is a discontinuity here, however, because no explicit link is made between earlier segments of the lecture and this part. For example, the chalk illustration used here is a ‘special case’, that was referred to earlier as something that students are assumed to have learned at school, but no link is made to this special case. | C – L – A | Lecturer only at 4a & 4b, then Lecturer & students at 4c |
| 4b                   | The lecturer explains that they can simplify the above situation by using a motion diagram, which he draws and labels (see sketch). He says, ‘replace mass $m$ with a dot’, and draws the velocity vectors to show the velocities at different times, as well as the acceleration downwards and the force of gravity downwards. He then relates the diagram to the formula $W_F = F s \cos \theta$ and at the same time reminds the students of the  |  | The lecturer first represents the concrete example in a sketch (pictorial representation), then by means of a motion diagram (physical representation). This represents a shift from the C to the L level. The motion diagram is coded at the L level because students are familiar with this representation. The motion diagram here is used to link familiar concepts (velocity and acceleration) to a new concept (work done). It is also used to condense the concrete             |           |  |

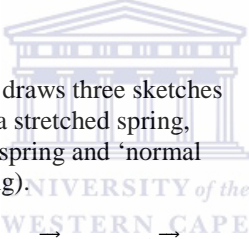
|    |  |  |   |  |  |
|----|--|--|---|--|--|
|    | <p>meaning of the dot in-between the two vector symbols, <math>\vec{F}</math> and <math>\vec{s}</math>. Then, he asks the students about the size of the angle between the two vectors and one of them says 'it is zero'. Then, he links the student's answer to the formula by writing <math>W_F = F_g s \cos 0^0</math>, on the board and relating this to potential energy.</p>   |  $  \begin{aligned}  W_F &= \vec{F}_g \cdot \vec{s} \\  &= F_g s \cos 0^0 \quad (\cos 0^0 = 1) \\  &= F_g \cdot s \quad (F_g \parallel s) \\  &= mgh \text{ (potential energy)}  \end{aligned}  $        | <p>situation into a denser physics representation.</p> <p>The lecturer then relates the motion diagram to the formula, with <math>\vec{F}</math> and <math>\vec{s}</math> represented to explain the principle – <math>W_F = F_g s \cos 0^0</math>. This continues to be coded at the L level.</p> <p>The lecturer's comment - 'replace mass m with a dot' - seems to take for granted that students appreciate and understand the 'point particle model' from a physics perspective. In other words, a significant amount of physics meaning is condensed in this brief comment.</p>   |  |  |
| 4c | <p>The lecturer thereafter asks the students about the velocity of the body as it falls – a student answers that it will increase, and the lecturer asks, 'How do you know that?' Then the lecturer himself answers the question by showing on the diagram that the velocity and the acceleration are in the same direction, therefore, the body's velocity will increase – 'it will speed up'. He then asks the students whether the work done (WD) is positive or negative and what it means if the body speeds up. He describes this symbolically on the diagram (<math>WD &gt; 0</math>), in other words, WD is positive.</p> <p>He does the same for the case of a body moving vertically upwards. He draws another sketch and motion diagram (see next column), and from this shows that the velocity is decreasing and the work done is negative (<math>WD &lt; 0</math>). He notes that, 'The negative answer here means</p> |  $  \begin{aligned}  W_F &= \vec{F}_g \cdot \vec{s} \\  &= F_g s \cos 180^0 \quad (\cos 180^0 = -1) \\  &= -F_g \cdot s \quad (F_g \parallel s) \\  &= -mgh \text{ (potential energy)}  \end{aligned}  $ | <p>The lecturer uses the two motion diagrams (for upward and downward motion of an object) in order to link the status of the velocity (increasing/decreasing) to the status of work done (positive/negative): <math>WD &gt; 0</math>/ <math>WD &lt; 0</math>. This is coded as A level.</p> <p>The extension of the example (for upward motion) serves to illustrate the relationship between the signs assigned to the velocity and the acceleration and the work done by the gravitational force. Being able to appreciate this relationship calls for a sophisticated level of abstraction (therefore this segment is coded A).</p> |  |  |




|                       |  |  |   |       |   |
|-----------------------|--|--|---|-------|---|
|                       | something: it means the body slows down, therefore, negative work is done’.  |  |   |       |   |
| 5<br>27 minutes<br>5a | He continues with the second example, and writes on the board ‘force to accelerate a body: $F_{acc} = F_{net}$ ’ and notes that one can use Newton’s 2 <sup>nd</sup> Law to calculate the work done. He then gives a verbal example: ‘Let’s say you are driving your car with the velocity $v_1$ , the car has a mass $m$ , you are driving and have a displacement $s$ and your new velocity is now $v_2$ .’ While he describes the problem verbally, he simultaneously draws a sketch of the problem. He notes that the car’s velocity is increasing from $v_1$ to $v_2$ , and therefore ‘that implies there is some acceleration, that is changing velocity’. | 2. Force to accelerate a body:<br>$F_{acc} = F_{net}$<br>$(W_F = \vec{F} \cdot \vec{s})$<br>$W_{Fnet} = \vec{F}_{net} \cdot \vec{s} = mas.$<br><br>The lecturer draws a sketch of the situation. | A new, implicitly linked example is introduced (creating the discontinuity shown on the semantic profile).<br><br>This verbal example is coded at the L level because it deals with familiar concepts of velocity and acceleration.   | L – A | Lecturer only at 5a, then Lecturer & students at 5b |
| 5b                    | He relates the generalised definition of work done ( $W_F = \vec{F} \cdot \vec{s}$ ) to Newton’s 2 <sup>nd</sup> Law by explaining and writing $W_{Fnet} = \vec{F}_{net} \cdot \vec{s} = mas.$<br><br>He says, ‘I would like to write this in terms of velocity’. He verbally gives the students all the equation of motion formulae and from those equations he chooses one that is possible to be used in calculating $v_2$ .:<br>$v^2 = v_0^2 + 2a(s - s_0)$<br><br>The lecturer shows the students how to get from this equation of motion to the formula of work done, viz. $W_{Fnet} = \vec{F}_{net} \cdot \vec{s} = mas.$                                 | <br>UNIVERSITY of the WESTERN CAPE   | Here the lecturer is linking to Newton’s 2 <sup>nd</sup> Law and reminding students of the link between acceleration and a resultant force on the car (L level)<br><br>He also reminds students of familiar equations of motion (L level).<br><br>The shape of the semantic profile from 5a (t=17min) to 5b (t=20 min) indicates that the lecturer is in the process of building on familiar concepts (L level) in order to generate a new, unfamiliar concept (in 5b) – (A level).<br><br>The lecturer is linking two familiar symbolic representations – of an equation of motion and work done – to generate a new, unfamiliar symbolic representation (A level):<br>$W_{Fnet} = \frac{1}{2} m v_2^2 - \frac{1}{2} m v_1^2.$ |       |   |

|  |  |  |   |                  |                      |
|--|--|--|---|------------------|----------------------|
|  | <p>In other words, he uses <math>v^2 = v_0^2 + 2a(s - s_0)</math> in a substitution for 'as' to derive <math>W_{\text{Fnet}} = \frac{1}{2}mv_2^2 - \frac{1}{2}mv_1^2</math>.</p> <p>Then, he gives the students an example showing the application of the relationship: <math>W_{\text{Fnet}} = \frac{1}{2}mv_2^2 - \frac{1}{2}mv_1^2</math>. He draws a sketch, before overlaying a FBD on top of this. The students are required to solve for <math>v_2</math> using an equation of motion <math>v_2</math> and then use the formula <math>W_{\text{Fnet}} = \frac{1}{2}mv_2^2 - \frac{1}{2}mv_1^2</math> to find the value of <math>W_{\text{Fnet}}</math>.</p> <p>He gives the students hints on how to go about it (e.g. 'Let's look at N11 and use the equation of motion, to find the unknown,' etc.). The students are thus using the equations to solve for the unknowns. As they work, he asks them to call out their calculated values.</p> <p>He notes the relationship between the work done by the resultant force and the change in kinetic energy, and explains that this is called the work-energy theorem.</p> |                              | <p>The interpretation of this concept at this stage is very abstract. It is thus coded as A because of its dense symbolic representation, which has not yet been unpacked as the work-energy theorem.</p> <p>This application of the new relationship is coded as A because the student engagement is at the level of working with the new symbolic representation.</p> <p>After the application, the lecturer introduces a new term for the relationship between the work done and the change in kinetic energy – the 'work-energy theorem'. This section is still coded at A level.</p> |                  |                      |
| <p>6<br/>2 minutes</p> <p>6a</p> <p>6b</p> | <p>He continues with the third example: work done by <i>friction</i>, <math>f_k</math>. He gives the students a verbal example of an object sliding across a surface, and then demonstrates this by pushing an object across the floor and explaining the effect of the frictional force on the object.</p> <p>He uses a sketch to explain the work done by the frictional force.</p>  | <p>3. Friction, <math>f_k</math></p> <p>The lecturer draws a sketch of an object sliding across a surface.</p> | <p>This is initially coded C because the lecturer starts with a concrete demonstration.</p> <p>The sketch is used to link the demonstration with the concept of work done by a</p>  | <p>C – L – A</p> | <p>Lecturer only</p> |

|  |  |  |  |           |               |
|--|--|--|--|-----------|---------------|
| 6c   | <p>He writes this as<br/> <math>W_{f_k} = \vec{F}_{f_k} \cdot \vec{s} = -f_k \cdot s</math></p> <p>He explains that the negative sign is there because of the angle between the two vectors.</p>   | $W_{f_k} = \vec{F}_{f_k} \cdot \vec{s} = -f_k \cdot s;$  | <p>frictional force (coded L).</p> <p>The new concept here is that work done due to frictional force will be negative. This is coded A, because the dense representation <math>W_{f_k} = \vec{F}_{f_k} \cdot \vec{s} = -f_k \cdot s</math> is new in the context of work done.</p> <p>The explanation of work done by a frictional force is abstracted very quickly (as indicated by the semantic profile, this entire example only took 2 minutes).</p>   |           |               |
| <p>7<br/>3 minutes</p> <p>7a</p> <p>7b</p> <p>7c</p> | <p>The lecturer introduces the fourth example, <i>centripetal force</i>, <math>\vec{F}_{cent}</math>. He notes: ‘This is the force that keeps the body towards the central path’. He draws a sketch of a body in circular motion and labels the force and the displacement.</p> <p>He says ‘by definition, <math>W_{F_{cent}} = \vec{F}_{cent} \cdot \vec{s} = 0</math>’ because of the angle between the force (<math>\vec{F}_{cent}</math>) and the displacement (<math>\vec{s}</math>).</p> <p>He then says: ‘If you were taught that work done is force times distance, you can see from these numbers of cases like this one (<i>pointing at the board</i>) it is not: work done is not force times distance, it is <math>F \cdot s</math> (F.s). You need to take account of the angle between those two vectors.’</p> <p>The lecturer summarises the previous four examples; he says, ‘If you are looking at all these cases, you’ll see that to swing an object around (<i>showing this by hand</i>), the force there is constant; if you take a frictional force, which is <math>\mu_k</math> times <math>F_N</math>,</p> | <p>The lecturer draws a sketch of a body in circular motion</p> $W_{F_{cent}} = \vec{F}_{cent} \cdot \vec{s} = 0$  | <p>The example is presented in a sketch and is somewhat abstracted, viz. it refers to ‘a body’, rather than to a concrete example of circular motion, and is therefore coded as L level.</p> <p>The new concept here is the work done by the centripetal force. This is coded A because the explanation of work done by a centripetal force is abstracted very quickly (as indicated by the semantic profile, 7a to 7b took only 2 minutes).</p> <p>Here the lecturer is summarising the 4 previous examples and relating them to the school definition of work done in order to highlight the importance of the angle between the vectors (which is assumed to be zero in the ‘school example’). He seems to be implicitly linking back to the earlier ‘suitcase’ example, but this link is only assumed. This part is coded as L.</p> <p>In this part, the lecturer links all four previous examples to an introduction of the fifth example (part 8). He is highlighting the fact that all the previous examples involved <u>constant</u> forces. This is still coded as L.</p> | L – A – L | Lecturer only |

|                       |  |  |   |                                  |               |
|-----------------------|--|--|---|----------------------------------|---------------|
|                       | where $F_N$ is a constant, so it means the frictional force is constant; if you look at the case of a body falling under gravity ( <i>dropping a piece of chalk downwards</i> ), the gravitational force is constant, $mg$ doesn't change. What happens now if the force <u>could</u> change?'   |  | He then poses the question 'What happens now if the force <u>could</u> change?'   |                                  |               |
| 8<br>11 minutes<br>8a | The lecturer introduces the fifth example, work done by a <b>varying force</b> , $\vec{F}_{spring}$ . He gives the students an example verbally and uses the spring to demonstrate the varying forces acting on the spring, when stretching or compressing the spring.   |  | This part is coded C because the lecturer uses a spring to demonstrate the forces acting on the string at various positions.  | L – C – L – A<br>– L – C – L – A | Lecturer only |
| 8b                    | He draws three sketches to show the relationship between the restoring force of the spring and the displacement (stretched spring, compressed spring and 'normal length' spring). He explicitly shows the labelling of displacement in each case (e.g. $x = 0$ when the spring is in normal length), as well as the $\vec{F}_{spring}$ and $\vec{F}_{applied}$ when the spring is stretched or compressed. |  <p>The lecturer draws three sketches of a spring (a stretched spring, compressed spring and 'normal length' spring).<br/>He labels <math>x = 0</math>, <math>\vec{F}_{spring}</math> and <math>\vec{F}_{applied}</math></p> | <p>The lecturer moves from the concrete example to a representation of this in a sketch, repacking the situation in order to introduce the relevant physics terms 'restoring force, which is '<math>F_{spring}</math>', '<math>F_{applied}</math>', and 'displacement <math>x</math>'.</p> <p>This is coded as the L level.</p> |                                  |               |
| 8c                    | He then shows that $\vec{F}_{spring}$ and $\vec{F}_{applied}$ are related through Newton's 3 <sup>rd</sup> law. He shows symbolically that the $\vec{F}_{spring}$ and hence $\vec{F}_{applied}$ are directly proportional to the displacement:<br>$x \propto \vec{F}_{applied}$  | The lecturer writes the explanation symbolically on the board:<br>$x \propto \vec{F}_{applied}$  | This part is coded as A, since the emphasis here is on the concept of a varying force, which is new to the students. The concept of a force varying with displacement is represented in dense symbolic form.  |                                  |               |
|                       | The lecturer relates the symbolic representation above to the sketches by pointing out the various displacements and forces.   |  | This part is coded as L because the lecturer is unpacking the symbolic representation by using the sketches.  |                                  |               |

|    |   |  |  |  |  |
|----|---|--|--|--|--|
| 8d | The lecturer now uses the spring to show the above relationship. He asks, 'What does ' $x \propto \vec{F}_{\text{applied}}$ ' mean?' He demonstrates that, if one stretches the spring a certain amount, one needs to apply a certain force, and if one doubles the force, the displacement will be double. | $\vec{F}_{\text{applied}} = kx$<br>$\vec{F}_{\text{spring}} = -kx$<br> | The lecturer now links the abstract and linking concepts to the concrete example of the spring (coded C).  |  |  |
| 8e | The lecturer then notes: 'In maths we write this as ' $\vec{F}_{\text{applied}} = kx$ .' He introduces the concept of the spring constant k, with its unit $\text{Nm}^{-1}$ and links this to the hardness or softness of a spring.   |  | This part is coded L because the lecturer is explicitly linking the familiar maths concept of a constant to the notion of a spring constant k.   |  |  |
| 8f | Since ' $\vec{F}_{\text{spring}}$ ' is in the opposite direction to ' $\vec{F}_{\text{applied}}$ ', then ' $\vec{F}_{\text{spring}} = -kx$ '. He introduces this as Hooke's Law.  |  | This part is coded A because the lecture introduces a new physics concept – Hooke's Law. It condenses much meaning within its symbolic representation (viz. the proportionality of F and x; the reason for the negative sign). |  |  |
| 8g |   |  |  |  |  |

### 6.2.2.1 Semantic profile of the Mainstream course lecture sequence 1

The shifts in SG and SD (which relate to the shifts between Concrete, Linking and Abstract levels) are represented in the form of a *semantic profile* in Figure 6.1 below.

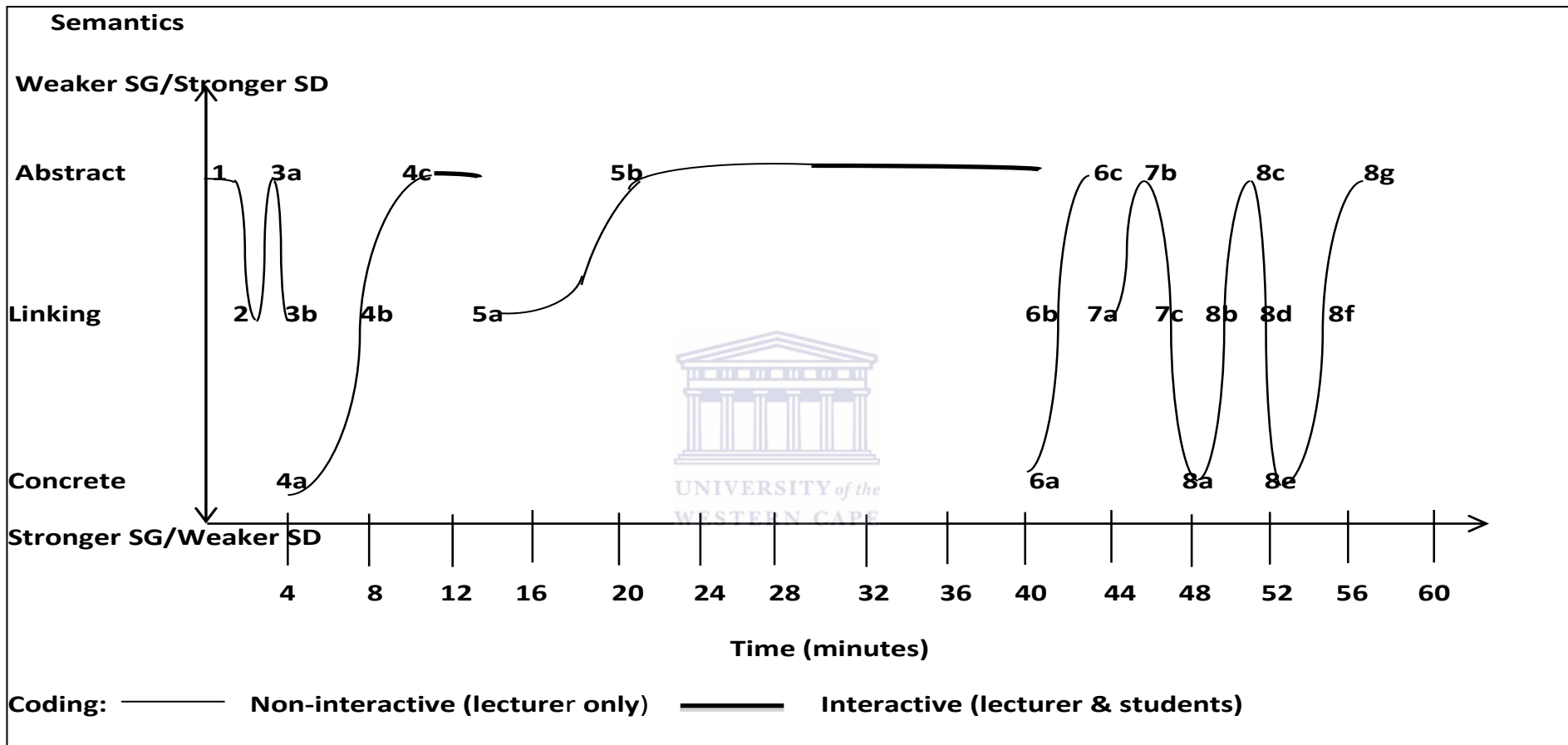


Figure 6.1: The semantic profile for the Mainstream lecture sequence 1 (Topic: Work-Energy)

### 6.2.2.2 Overview of the Mainstream course lecture sequence 1

- In part 1, from 0 minutes to 1.5 minutes (*for 1.5 minutes*) (starts at A): the lecturer defines the concept ‘work done’ both verbally and symbolically.
- In part 2, from 1.5 minutes to 2 minutes (*for 0.5 minutes*) (from A to L): the lecturer explains the concept by means of an example.
- In part 3, from 2 minutes to 4 minutes (*for 2 minutes*) (from L to A to L): the lecturer introduces the concept graphically (at 3a) and ‘unpacks’ it (at 3b).
- In part 4, from 4 minutes to 13 minutes (*for 9 minutes*) (from C to L to A): the lecturer introduces the first example of finding the work done (concept of *gravitational force* [ $F_g$ ]) by means of a demonstration and verbally (at 4a) then diagrammatically (at 4b); he also introduces the abstract relationship between the change in velocity and the work done (4c).
- In part 5, from 13 minutes to 40 minutes (*for 27 minutes*) (from L to A): the lecturer introduces the second example verbally (*force to accelerate a body:  $F_{acc} = F_{net}$* ), before explaining it both with a sketch (at 5a) and symbolically (at 5b). Students work with the application of the new Work-Energy concept in 5b.
- In part 6, from 40 minutes to 42 minutes (*for 2 minutes*) (from C to L to A): the lecturer introduces the third example verbally (*friction,  $f_k$* ), before explaining it by means of a demonstration (at 6a), a sketch (at 6b) and symbols (at 6c).
- In part 7, from 42 minutes to 45 minutes (*for 3 minutes*) (from L to A to L): the lecturer introduces the fourth example verbally (*centripetal force,  $F_{cent}$* ) (at 7a), before explaining it by means of a sketch and symbolically (at 7b). Then the lecturer summarises the previous four examples as all involving *constant* forces. Then (at 7c) the lecturer links to the fifth example in part 8, while posing a question about non-constant forces.
- In part 8, from 45 minutes to 56 minutes (*for 11 minutes*) (sequence of L – C – L – A – L – C – L – A): the lecturer introduces the fifth example verbally (*varying forces,  $F_{spring}$* ), before explaining it by means of a spring demonstration (at 8a), a sketch (at 8b) and symbolically  $x \propto \vec{F}_{\text{applied}}$  (at 8c); the lecturer uses a sketch (at 8d) to link this symbolic representation to the varying displacements shown in the earlier spring demonstration; then he returns to a concrete demonstration (at 8e) in order to build towards the concept of a spring constant (at 8f), and finally he presents the dense, abstract physics principle of Hooke’s Law (at 8g).

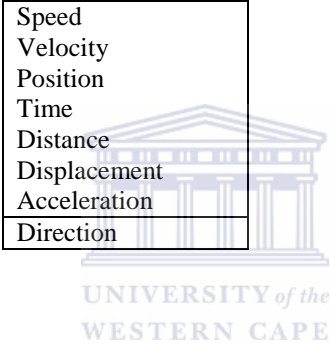
### 6.2.3 *Extended course: Lecture sequence 1*



Here, the same analytical process was followed as in the lecture sequence relating to the Mainstream course. The aim of the Extended course's lecture sequence was to develop students' understanding of the concepts of Position and Displacement. The selected topic was completed over two lectures, 60 minutes each; as shown in the semantic profile below, the two lectures actually took 112 minutes, with the remaining 8 minutes being used for administration and the explanation of a pre-reading 'warm-up' task. For analytical purposes, the lecture sequence was broken up into 7 parts. As noted above, Table 6.2 contains the detailed information, which can be used to interpret the shape of the semantic profile illustrated in Figure 6.2 below the table.

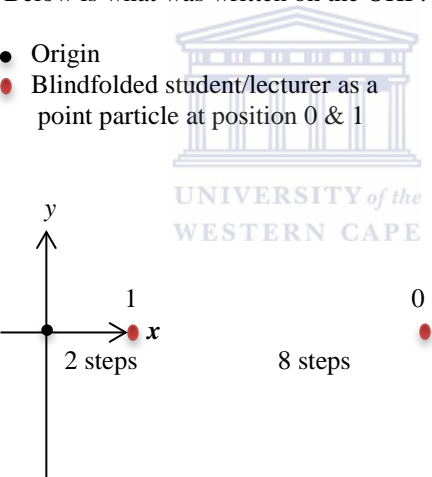





Table 6.2: Summary data for Extended lecture sequence 1 (Topic: Position & Displacement)


| Parts of the lecture and the time taken (approximate) | What happens in class  | What is written on the overhead projector (OHP)   | Coding comments  | Position and shifts in SG and SD:<br>Abstract = A<br>Linking = L<br>Concrete = C | Communicative approach (interactive or non-interactive) |
|---|--|---|--|--|---|
| 1<br><br>2 minutes                                    | <p>The lecturer starts the <b>first lecture</b> by focusing on students' prior knowledge about motion. He asks students to name any physical quantities that can describe motion: 'What are key concepts or key aspects of motion?' The students call out concepts and the lecturer lists the words on the OHP:</p> <p>As the students are calling out the concepts, the lecturer asks about them. For example, he says, 'How do you describe speed, displacement, etc.?' Similarly, he asks, 'Is direction a vector quantity or not?', before explaining the concepts and writing on the OHP:</p> <p>'Direction is what gives a quantity its vector property'.</p> <p>He explains, 'Therefore, as a physicist, we perceive that quantity as a vector'. He also asks the students to write the explanation in their books, since they had been uncertain about this point.</p> |  <p>'Direction is what gives a quantity its vector property',</p> | <p>This is coded as Concrete (C) because the lecturer focuses on <i>students' prior knowledge</i> (from school/daily life) to start the <i>new</i> lesson by asking the students to name <i>any</i> physical quantities ('key concepts/aspects') that can describe motion.</p> | C  | Lecturer & students                                     |

|                                   |  |  |   |              |                                |
|-----------------------------------|--|--|---|--------------|--------------------------------|
| <p>2</p> <p><i>10 minutes</i></p> | <p>From this list, the lecturer asks the students to identify which quantities are vectors.</p> <p>Discussion follows in small groups, and then group feedback is given in the whole class.</p> <p>Students then vote on which concepts are vectors or not.</p> <p>The lecturer realizes that most students think that ‘position’ is not a vector. He then says, ‘I’m now going to deal with displacement and position for you in a very explicit way; you’ll see that position and displacement are very closely related but they are NOT the same thing. Afterwards, I’ll ask you the question again: is position a vector or a scalar?’</p> | <p>Students’ votes are added next to the list above</p>  | <p>This is coded as Linking level (L), since the students need to apply the ‘vector’ concept to the list of quantities. This draws on a concept from school, so it is familiar but the meaning is condensed in the term ‘vector’.</p> | <p>C – L</p> | <p>Lecturer &amp; students</p> |
| <p>3</p> <p><i>20 minutes</i></p> | <p>The lecturer then introduces a class activity, where a student is blindfolded and the other students (working in their groups) are required to direct the student from the classroom door to find an object in the three-dimensional space.</p> <p>The students are instructed to describe the situation in sketches and words. In their groups, students thus enact the situation, counting the steps from where the blindfolded student is to where the object is placed (<i>here, students are checking and comparing their steps to</i></p>   |    | <p>Students represent the motion in different (concrete) ways – verbal, written, gestures (steps), sketches (showing initial position to final position).</p> <p>Therefore this is coded as C level.</p>                              | <p>L – C</p> | <p>Lecturer &amp; students</p> |

|                 |  |   |   |                                      |                     |
|-----------------|--|---|---|--------------------------------------|---------------------|
|                 | <p><i>the blindfolded students' steps; one of them in one group noted that the steps were not the same, and said, 'he is not tall as you are!'</i></p> <p>After their long discussion, group feedback occurs.</p>  |   |   |                                      |                     |
| 4<br>25 minutes | <p>The lecturer asks volunteer groups to summarise their discussion on the OHP (using sketches or words to describe the path to be taken by the blindfolded student). To describe direction, some groups use 'left and right', while others use 'forward and backward'.</p> <p>In the following sequence (4b-4f), the lecturer enacts their descriptions in order to link students' <i>concrete</i> explanations to the <i>abstract</i> concepts of 'position vector', 'origin', and 'co-ordinate system'.</p> | <p>Below is what was written on the OHP:</p> <ul style="list-style-type: none"> <li>● Origin</li> <li>● Blindfolded student/lecturer as a point particle at position 0 &amp; 1</li> </ul>  | <p>Students summarise explanations on OHP. The lecturer enacts their descriptions to link students' concrete explanations to abstract concepts; this is done sequentially for each of the following concepts: co-ordinate system, origin, position vector.</p> <p>The lecturer links students' <i>concrete</i> experiences (e.g. walking to the front wall; left or right) to <i>abstract</i> concepts (e.g. choosing a co-ordinate system).</p> <p>He repeats this move from concrete to abstract (C – L – A) for the other relevant concepts – origin, position vector condensing meanings into physics terms – 'vector', 'co-ordinate system', 'origin'.</p> | <p>C – L – A – L<br/>– C – L – A</p> | Lecturer & students |
| 4a              |  |   |   |                                      |                     |
| 4b              | <p>To start with, they need to agree on a shared co-ordinate system. He links the <i>concrete</i> description 'walking to the front wall' to the <i>abstract concept</i> of choosing a positive x-direction on a co-ordinate system.</p>   |   |   |                                      |                     |
| 4c              | <p>When they direct him towards the object, he asks them at one point to describe where he is – viz. his position relative to his starting point. A student volunteers: 'You are eight steps away from the origin, in the positive x-direction'.</p>   |   |   |                                      |                     |

|                 |   |  |  |       |                     |
|-----------------|---|--|--|-------|---------------------|
| 4d              | The lecturer relates the <i>concrete</i> descriptions of ‘starting point’ and ‘eight steps away from the origin’ to the <i>abstract concepts</i> of origin (the door), the choice of co-ordinate system, and position as a vector quantity. He summarises it as follows:  |  |  |       |                     |
| 4e              | ‘I can’t describe my position fully if I don’t use a vector quantity to describe it. So position is not a scalar, it is in fact a vector – because you [i.e. students] correctly used magnitude and direction to describe this point in space [where he is standing] relative to the origin and a coordinate axis’.             |  |  |       |                     |
| 4f              | The lecturer then asks the students to write in their books, ‘position vector represents the distance and direction away from the origin’.  |  |  |       |                     |
| 5<br>30 minutes | Since this part is the start of the <b>second lecture</b> , the lecturer starts the lecture by recapping what he was doing in parts 4a-f in the previous lecture. The lecturer uses the students’ sketches from the previous lecture to describe how these position vector quantities are represented <i>diagrammatically</i> . |  |  | A – L | Lecturer & students |
| 5a              | He unpacks the dense diagrammatic representation of a vector into its constituent parts and their meanings. He notes: ‘The vector as an arrow has an important information... The <i>line</i>   |  |  |       |                     |
| 5b              |   |  |  |       |                     |



|                 |  |  |   |           |               |
|-----------------|--|--|---|-----------|---------------|
|                 | steps, + y.'   |  |   |           |               |
| 6<br>15 minutes | The lecturer introduces an <i>abstract generalizing concept</i> of 'displacement vector' as the difference between the final and initial position vectors. He writes this in symbolic form: the dense <i>symbolic</i> representation of a displacement vector – ( $\Delta\vec{r}_{01} = \vec{r}_1 - \vec{r}_0$ ).  | $\Delta\vec{r}_{01} = \vec{r}_1 - \vec{r}_0$   | This is coded as Abstract level (A), since the lecturer introduces an abstract generalizing concept (viz. the concept of a 'displacement vector').  | L – A – L | Lecturer only |
| 6a              |  |  |   |           |               |
| 6b              | He unpacks the dense <i>symbolic</i> representation of a displacement vector into its constituent parts and their meanings and poses questions, such as: 'What does delta mean? What do the subscripts 1 and 0 mean? What do the arrows above r mean?' At one stage, he asks, 'How do we then describe displacement? Where is the tail of the black arrow ( <i>i.e.</i> 8 steps pointing to the left on the diagram); what does that represent? Can we use the same symbol if it is not the same as the position vector?' In-between these questions, he lets the students respond in a superficial way, before explaining the concepts in detail. |    | <p>He links the concept of a 'displacement vector' back to the previous, concrete situation in part 3. He unpacks the dense <i>symbolic representation</i> of a vector – e.g. (<math>\Delta\vec{r}_{01} = \vec{r}_1 - \vec{r}_0</math>) - into its constituent parts and their meanings. This is coded as L.</p> <p>The lecturer dominates this summary discussion by giving detailed explanations; students are only involved in a very superficial way.</p> |           |               |
| 7<br>10 minutes | The lecturer relates the concept of the displacement vector and its symbolic representation ( $\Delta\vec{r}_{01} = \vec{r}_1 - \vec{r}_0$ ) back to the concrete blindfold exercise, with $r_1$ and $r_0$ being related to the steps taken by the students. Here, the lecturer is moving down from an abstract concept ( $\Delta\vec{r}_{01} = \vec{r}_1 - \vec{r}_0$ ) to the concrete example of  | $\begin{aligned} \Delta\vec{r}_{01} &= \vec{r}_1 - \vec{r}_0 \\ &= (2 \text{ steps, } + x) - (10 \text{ steps, } + x) \\ &= - (8 \text{ steps, } + x) \\ &= - 8 \text{ steps, } + x \end{aligned}$ <p style="text-align: center;">OR</p> $= 8 \text{ steps, } - x$ | <p>This is coded as C level, since the lecturer relates the concept of the displacement vector back to the concrete blindfold exercise, for example, by referring to the number of steps taken by the student.</p> <p>Here, the lecturer is moving down from an abstract concept (<math>\Delta\vec{r}_{01} = \vec{r}_1 - \vec{r}_0</math>) to a</p>   | L – C     | Lecturer only |

|  |  |   |   |  |  |
|--|--|---|---|--|--|
|  | that concept. He unpacks the meanings of the constituent parts of the symbolic representation in relation to the blindfold activity. He writes this on the OHP and explains: | $\therefore \Delta \vec{r}_{01} = 8 \text{ steps, } -x \text{ direction}$ | concrete example of that concept.<br><br>Also, he is unpacking the meaning of the constituent parts of the symbolic and diagrammatic representations in a concrete context. |  |  |
|--|--|---|---|--|--|

*Semantic profile of the Extended course lecture sequence 1*

The shifts in SG and SD (which relate to the shifts between Concrete, Linking and Abstract levels) are represented in the form of a *semantic profile* in Figure 6.2 below.



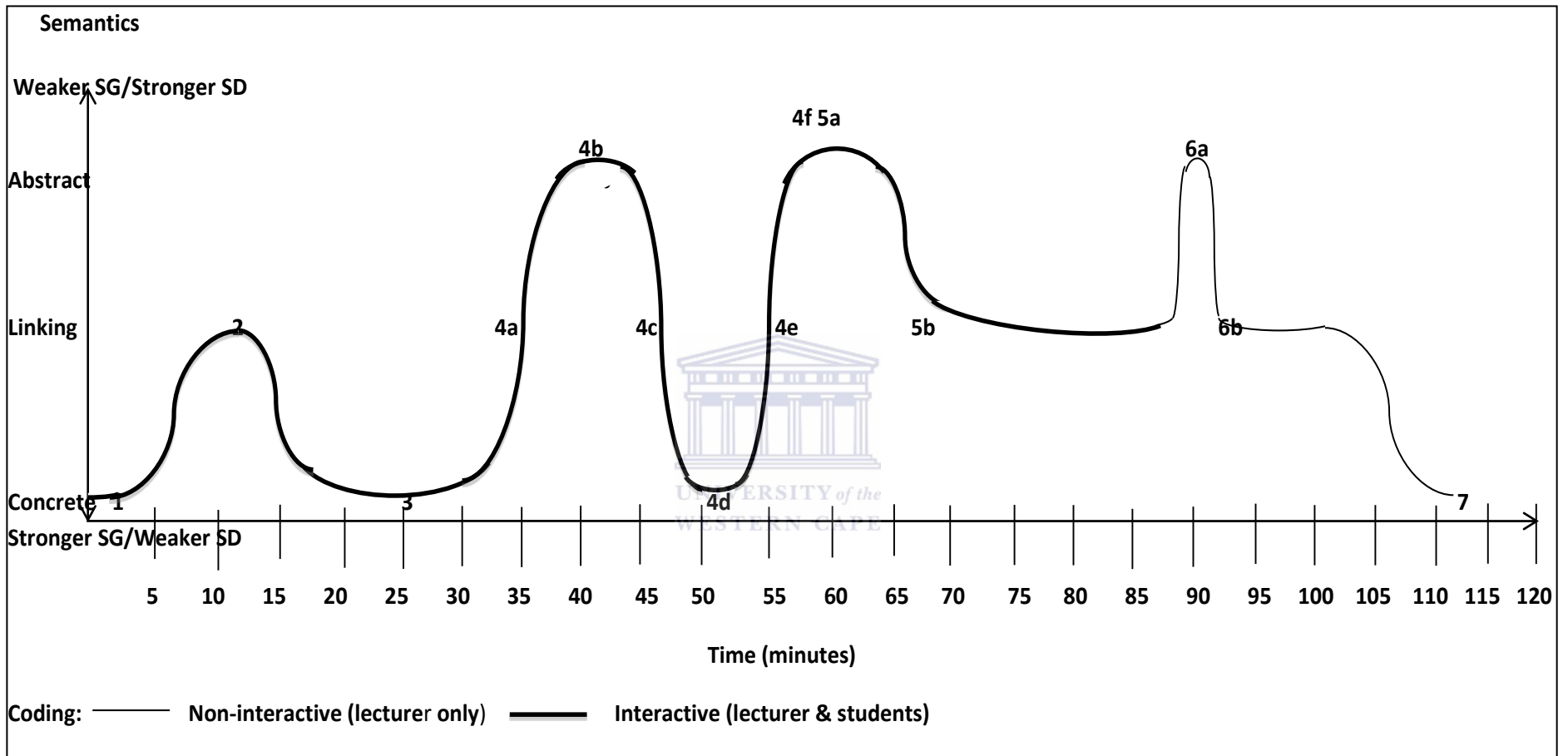


Figure 6.2: The semantic profile for the Extended lecture sequence 1 (Topic: Position & Displacement)



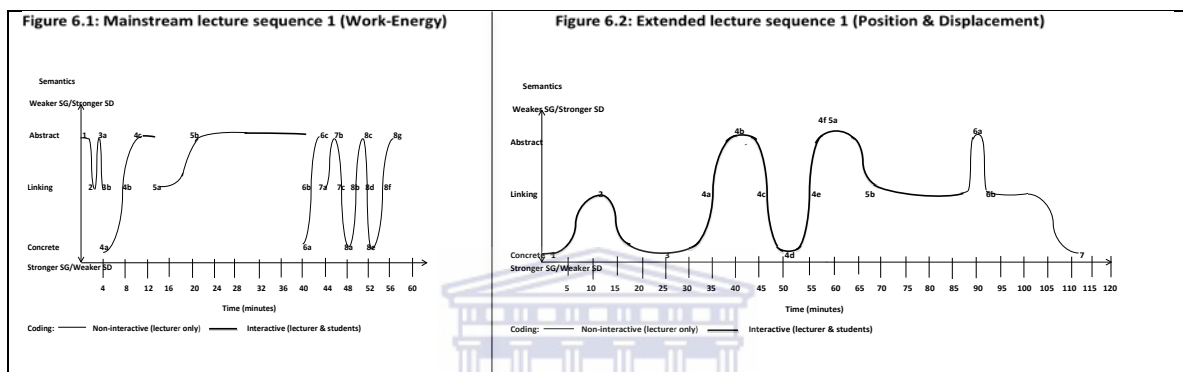
### 6.2.3.1 Overview of Extended course lecture sequence 1

- In part 1, from 0 minutes to 2 minutes (*for 2 minutes*) (starts at C): the first lecture starts with the lecturer establishing the students' prior knowledge on motion.
- In part 2, from 2 minutes to 12 minutes (*for 10 minutes*) (from C to L): students are required to apply the concept of 'vector' to a list of physical quantities related to motion. Since most students think that 'position' is not a vector quantity, the lecturer then introduces an activity (in part 3).
- In part 3, from 12 minutes to 32 minutes (*for 20 minutes*) (from L to C): the lecturer instructs the students to enact a 'blindfold activity' (a concrete experience of finding an object in a three-dimensional space).
- In part 4, from 32 minutes to 57 minutes (*for 25 minutes*) (sequence of C – L – A – L – C – L – A): based on group feedback, the lecturer links students' explanations to the abstract physics concept of 'position vector'; he translates students' sketches and words into a vector diagram, specifying a co-ordinate system and choosing an origin (from 4a to 4f).
- In part 5, from 57 minutes to 87 minutes (*for 30 minutes*) (start of the second lecture – from A to L): (5a) the lecturer recaps the concept of 'position vector', and then (5b) focuses on the representation of vectors, linking this to students' sketches from the previous lecture.
- In part 6, from 87 minutes to 102 minutes (*for 15 minutes*) (from L to A to L): (6a) the lecturer introduces the new concept of a 'displacement vector' in relation to the position vector, using dense symbolic representation; (6b) he thereafter unpacks this symbolic representation.
- In part 7, from 102 minutes to 112 minutes (*for 10 minutes*) (from L to C): the concepts of position and displacement vectors are related back to the concrete activity.

This section (Section 6.2) has presented two detailed analyses of lecture sequence 1 from the Mainstream and Extended courses. The lecture sequence from each course consists of lectures, which occurred at the same time during the academic year. As part of the analysis, semantic profiles of the pedagogical practices were constructed. Section 6.3 below provides a summary of these semantic profiles of pedagogical practice.

### 6.3 Summary of analysis of semantic profiles of pedagogical practice

This chapter has summarised the data on lecture sequences observed in the Mainstream and Extended physics courses, in order to characterise the pedagogical practices used in teaching the two topics (Work-Energy and Position & Displacement). In both cases, the lecture sequences were introducing a new topic to the students. The concepts of SG and SD – combined to form a semantic profile – offered a useful way of describing and mapping the pedagogical moves between representations.



**Figure 6.3: Semantic profiles for the pedagogical practices in the Mainstream and the Extended lecture sequence 1**

The analysis shows that the semantic profiles (shown side-by-side in Figure 6.3) for the respective lecture sequences described above are quite different. Firstly, they have different **entry/exit points** (in terms of starting or ending with higher or lower SG and SD): the Extended lecture sequence starts and ends at the Concrete level, while the Mainstream lecture sequence starts and ends at the Abstract level. Some data from Tables 6.1 and 6.2 is drawn on here to illustrate this point.

As indicated, the Mainstream lecture sequence starts at the *Abstract level*: the abstract concept of work is introduced and immediately expressed in dense symbolic representation (see Table 6.1, part 1 & 2):

The lecturer starts by asking the class for a definition of work: *‘If someone asks you, how do you define work, what do you say?’* He answers the question himself: *‘F dot s’* and writes this symbolically on the board: he then unpacks this as  $F \cos \theta$  and illustrates the significance of the angle between  $F$  and  $s$  with an example of a suitcase

being carried. This is signified by a downward shift on the semantic continuum to the *Linking level*.

In contrast, the Extended lecture sequence starts at the *Concrete level*: the lecturer elicits students' prior knowledge (from school/daily life) about motion by asking them to name any physical that can describe motion (see Table 6.2, part 1-3):

The lecturer starts by asking: 'What are the key concepts or key aspects of motion?' Together the class generates a list of quantities (speed, position, time, distance, displacement, etc.). He asks the students to apply the 'vector' concept to the list, and when he realises that most students think that position is not a vector, he introduces a blindfold activity to address this erroneous view: a student is blindfolded and other students direct the student from the classroom door to find an object in three-dimensional space: 'I am now going to deal with displacement and position for you in a very explicit way [through the blindfold activity]. You'll see that position and displacement are very closely related, but they are not the same thing. Afterwards, I'll ask you the same question: is position a vector or a scalar?'

Similarly, the **exit points** of the two lecture sequences are also different: *Abstract* in the Mainstream case and *Concrete* in the Extended case. The Mainstream lecturer has explored the concept of work done by a varying force, building up towards a dense symbolic representation of Hooke's Law (see Table 6.1, part 8g). This is coded as *Abstract*. In the Extended course (see Table 6.2, part 7), the lecturer relates the concept of 'displacement vector' and its symbolic representation ( $\Delta\vec{r}_{01} = \vec{r}_1 - \vec{r}_0$ ) back to the concrete blindfold activity, with ( $\Delta\vec{r}_{01} = \vec{r}_1 - \vec{r}_0$ ) being related to the number of steps taken by the students. This is indicated by a downward shift on the semantic continuum to the *Concrete level*.

Secondly, different **semantic ranges** were observed (the extent to which the pedagogical practices focus on the Concrete, Linking or Abstract level); in both lecture sequences, a significant part of the lecture is spent at the Linking level; however, the Mainstream lecture sequence spends more time at the *Abstract* level than at the *Concrete* level, whereas the Extended lecture sequence spends more time at the *Concrete* level. As the semantic profile indicates, when the Mainstream lecture sequence is at the *Concrete* level (at 4a, 6a, 8a and 8e), this is only for a short time before moving back to the Linking level.

Thirdly, the semantic profiles showed different degrees of **compression** (in other words, the frequency with which shifts between the various levels occur, or the time taken to move between levels). In parts of the semantic profile, where there is a series of movements through all the levels, it can be seen that the semantic profile is more compressed in the case of the Mainstream lecture. For instance, part 8 of the Mainstream lecture (Table 6.1, part 8) shows rapid shifts between Concrete and Abstract, as the lecturer explains the concept of work done by a varying force, moving between demonstrations, sketches, and symbols. The entire movement (moving from 8a through to 8g) takes 11 minutes. By comparison, part 4 of the Extended lecture (Table 6.2, part 4) has a very similar profile in terms of the shifts between Concrete and Abstract, as the lecturer translates students' sketches and explanations into a vector diagram and into the concepts of co-ordinate system, origin and position vector. In contrast to the Mainstream lecture, however, this entire movement in the Extended lecture (moving from 4a through to 4f) takes 25 minutes, more than twice as long. As was noted in Chapter 5 with regard to the curriculum structure, the pacing of the Extended course was slower than the Mainstream course, which means that the time available to deal with topics is more compressed in the Mainstream course.

The fourth difference is in terms of **who is involved in the semantic shifts or moves between the Abstract, Linking and Concrete levels**. As noted in Chapter 2, modes of interaction in a lecture can be characterised in terms of 'communicative approaches' (Mortimer & Scott, 2003). In this study, communication in lectures is characterised as either *interactive* or *non-interactive*, with interaction indicated on the semantic profile with a thick line, and non-interaction with a thin line. The coding on the semantic profiles shows an important difference in this regard. In the Mainstream lecture sequence, there is not much time for student engagement and the lecture consists largely of the lecturer introducing concepts, before setting up a problem: the lecturer introduces the representations needed for the problem (a sketch, followed by symbolic representation); the students are engaged only at the stage of substituting values into the symbolic representation. During part 4c (3 minutes), the lecturer poses some questions to the students (indicated by a thick line), although the lecturer answers some of these himself. In the second half of 5b, the lecturer again sets up an example and gives the students time (12 minutes) to work on this themselves (as indicated by the thick line).

In contrast, in the Extended lecture sequence, most of the time is spent on student engagement, with lecturer guidance (as shown by the thick line in the semantic profile). At the end of the lecture sequence, the lecturer summarises the main concepts that have been dealt with, and relates these back to the concrete context that had been introduced at the start of the lecture sequence (this non-interactive part of the lecture is indicated by a thin line).

## 6.4 Conclusion to Chapter 6

This chapter has examined two lecture sequences (one from the Mainstream course and one from the Extended course) that occurred at the *same time during the academic year*, and differences in the semantic profiles of these lecture sequences were discussed. It could be argued that the differences highlighted in the semantic profiles are due to the different topics being taught; the Extended lecture sequence was one of the first in Mechanics; the Mainstream lecture sequence occurred towards the end of Mechanics, and so the Mainstream lecture on Work-Energy was more conceptually advanced than the Extended lecture.

The chapter that follows will attempt to address this potential concern. Chapter 7 will look at another lecture sequence (sequence 2), which will examine *similar content knowledge* being taught in the Mainstream and the Extended courses. In this way, the study will examine to what extent the differences in semantic profiles are an artefact of the content knowledge being taught or an indication of difference pedagogical practices.

An important purpose of this chapter was to develop a methodologically rigorous process of characterising the semantic profiles of pedagogical practices. The data tables and the semantic profiles were intended to provide a ‘thick description’ (Geertz, 1973) of the data analysis process. The preliminary observations of the Extended and Mainstream lecture sequences made in this chapter will be elaborated on in Chapter 7, where further pedagogical practices are analysed.

## **Chapter 7:**

### **Pedagogical practices: The semantic profiles of Mainstream and Extended courses – lecture sequence 2**

#### **7.1 Introduction**

This chapter presents an analysis of the second lecture sequence relating to Research Question 1: *What is the nature of the Mainstream and Extended pedagogical practices in term of their semantic profiles (i.e. semantic gravity and semantic density)?* Chapter 6 focused on two introductory lecture sequences, which took place *at the same time* during the academic year, but with different content knowledge. The analysis in Chapter 6 identified some clear differences between the two lecture sequences. The objective of this chapter is to determine whether the differences in semantic profiles highlighted in the pedagogical practices considered in Chapter 6 were due to the different topics being taught. Therefore, Chapter 7 presents a lecture sequence from the Mainstream course and the Extended course that has *similar content knowledge* – the concept of Work-Energy.

This chapter will show that, in this second lecture sequence, the pedagogical practices of the Mainstream and Extended lectures are more similar to each other than the Mainstream and Extended pedagogical practices that were analysed in Chapter 6. However, there are still discernable differences in the shifts in SG and SD, which this chapter will highlight. The semantic profile will be used as an analytical tool to show in a detailed way the similarities or differences in these semantic shifts.

The following section discusses the details of the findings from lecture sequence 2 with regard to the respective pedagogical practices.

#### **7.2 Detailed analysis of lecture sequences from Mainstream and Extended courses**

This section presents an analysis of the pedagogical practices from lecture sequence 2 in the Mainstream and Extended courses. In both cases, the lectures were from the Work-Energy section. In undergraduate physics courses, the sequencing of topics in this section varies; some start with the concept of Work, followed by Energy, or vice versa. In this study, the

Mainstream course started this section with Work (see lecture sequence 1 in Chapter 6), with Energy being introduced in lecture sequence 2 (in Chapter 7); in contrast, the Extended course started with Energy, followed by Work (both discussed in lecture sequence 2 in Chapter 7). See Table 5.1 for the sequencing details.

From the observation data, summaries of each lecture sequence were constructed. Since the analytical process of constructing the semantic profiles was the same as in Chapter 6, the same rich ‘audit trail’ is not provided here. Instead, in this chapter only the semantic profiles are presented; the summary data is contained in Appendix 2. After the semantic profiles for the Mainstream and Extended lectures are illustrated below, these are analysed in Section 7.3 in terms of the similarities and differences that are observed.

### *7.2.1 Mainstream course: Lecture sequence 2*

This section analyses one 60-minute lecture (as shown below, the lecture took 55 minutes and the 5 remaining minutes were used for course administration). As mentioned earlier, the aim of the lecture sequence was to develop students’ understanding of the concepts of *energy* in physics. The lecture occurred just after lecture sequence 1, which was examined in Chapter 6.

#### *7.2.1.1 Semantic profile of the Mainstream course lecture sequence 2*

The analysis of the lecture sequence is presented in the semantic profile in Figure 7.1 below. The use of coding shown below the semantic profile is an indication of the communicative approaches that characterised each part of the lecture. An overview of the lecture sequence is given below the semantic profile (the summary data is given in Appendix 2A).

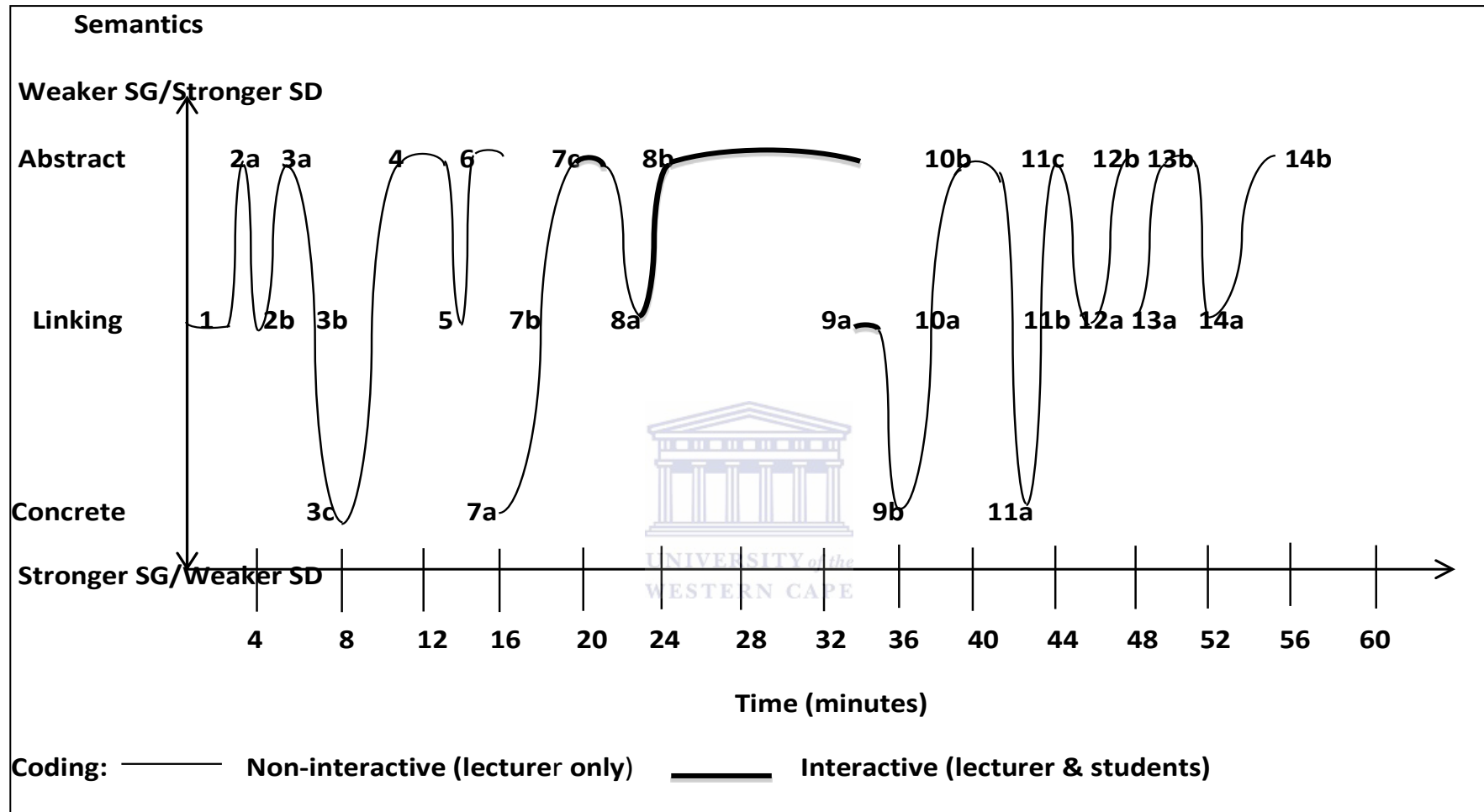


Figure 7.1: The semantic profile for the Mainstream lecture sequence 2 (Topic: Work-Energy)



### 7.2.1.2 Overview of Mainstream course lecture sequence 2

- In part 1, from 0 minutes to 4 minutes (*for 4 minutes*) (starts at L): the lecturer recaps important information from the previous lecture, drawing a sketch of a spring, to show how the restoring force varies when the spring is compressed or stretched, in relation to  $W_f = \vec{F} \cdot \vec{s}$ .
- In part 2, from 4 minutes to 5 minutes (*for 1 minute*) (from L to A to L): the lecturer draws a new graph of  $F_{\text{spring}}$  vs  $x$  and relates the concept of work done by a spring to the area under the graph (at 2a). Thereafter, the lecturer unpacks the graph, showing how the area of the graph can be written mathematically (at 2b).
- In part 3, from 5 minutes to 8 minutes (*for 3 minutes*) (sequence of L – A – L – C): the lecturer relates the area under the graph to the concept of work done, and writes:  $W_{\text{spring}} = -1/2kx^2$  (at 3a). The lecturer uses the sketch to explain the negative sign (at 3b) and demonstrates the stretching or compressing of a spring in relation to the formula (at 3c).
- In part 4, from 8 minutes to 13 minutes (*for 5 minutes*) (from C to A): the lecturer uses the graph and relates this to the mathematical principle of integration:  $W_{\text{spring}} = \int_0^x F dx$
- In part 5, from 13 minutes to 14 minutes (*for 1 minute*) (from A to L): the lecturer uses the graph to explain the meaning of the integral sign.
- In part 6, from 14 minutes to 16 minutes (*for 2 minutes*) (from L to A): the lecturer solves the integral to derive a new expression for  $W_{\text{spring}} = -1/2kx^2$ .
- In part 7, from 16 minutes to 20 minutes (*for 4 minutes*) (from C to L to A): the lecturer introduces the new concept of 'power' through a demonstration (at 7a), defines the concept (at 7b), discusses the symbol P used for power (in contrast to p for momentum) and then writes the definition of power symbolically (at 7c).
- In part 8, from 20 minutes to 34 minutes (*for 14 minutes*) (from A to L to A): the lecturer gives a verbal problem example to illustrate the new concept of power (at 8a); he asks the students to solve this, guiding them since the concept is new to them, and he also derives an alternative formulation for power (at 8b):  $\vec{F} \cdot \vec{v}_{\text{average}}$ .

- In part 9, from 34 minutes to 36 minutes (*for 2 minutes*) (from L to C): the lecturer introduces ‘another process, called energy’; he asks, ‘What is energy?’ He allows the students to answer and then writes a definition on the board (at 9a). Thereafter, the lecturer demonstrates dropping an object and explains the demonstration in terms of energy (at 9b).
- In part 10, from 36 minutes to 42 minutes (*for 6 minutes*) (from C to L to A): the lecturer condenses the demonstration example above by drawing a sketch to illustrate the concept of gravitational potential energy (U) (at 10a). He uses the sketch to derive a mathematical expression for the work done by a gravitational force in terms of the change in gravitational potential energy (U) (at 10b).
- In part 11, from 42 minutes to 44 minutes (*for 2 minutes*) (sequence of A – C – L – A): the lecturer now throws an object up to demonstrate a body that is going vertically upwards (at 11a). He draws a sketch of this (at 11b), and uses this sketch to derive a mathematical expression for the work done by a gravitational force in terms of the change in gravitational potential energy (at 11c).
- In part 12, from 44 minutes to 48 minutes (*for 4 minutes*) (from A to L to A): the lecturer signals that he will now focus on a second form of energy: kinetic energy. He gives a verbal example, before drawing a sketch and writing:  $K = \frac{1}{2}mv^2$  on the board (at 12a). He asks how kinetic energy is related to work done, and derives the Work-Energy Theorem on the board (at 12b).
- In part 13, from 48 minutes to 52 minutes (*for 4 minutes*) (from L to A): the lecturer gives a verbal example of a falling object and draws a sketch of the situation (at 13a); he asks ‘What is the final velocity?’ He reminds them on the board that this can be determined using a kinematic equation of motion. He introduces a new way of solving the problem, using the Work-Energy Theorem. He writes the Work-Energy Theorem on the board and lets the students find the final answer (at 13b).
- In part 14, from 52 minutes to 55 minutes (*for 3 minutes*) (from A to L to A): the lecturer recaps the Work-Energy Theorem for a falling object and writes on the board  $W_{res} = \Delta K$  (at 14a); thereafter, he relates the work done by the gravitational force to the change in energy (at 14b).

### 7.2.2 *Extended course: Lecture sequence 2*

Here, I analyse two 60-minute lectures. Note that, as shown in the summary below, the lecture sequence took 75 minutes, with the remaining 45 minutes used for the class activity, the pre-reading ‘warm-up’ task and administration. The aim of this lecture sequence is to develop students’ understanding of the concepts of Work-Energy in physics.

#### 7.2.2.1 *Semantic profile of the Extended course lecture sequence 2*

In Figure 7.2 below, the analysis of the lecture sequence in terms of SG and SD is illustrated. The use of coding in the semantic profile is an indication of the sort of communicative approaches taking place in the lecture. An overview of the lecture sequence is given below the semantic profile (remember that the summary data is contained in Appendix 2B).



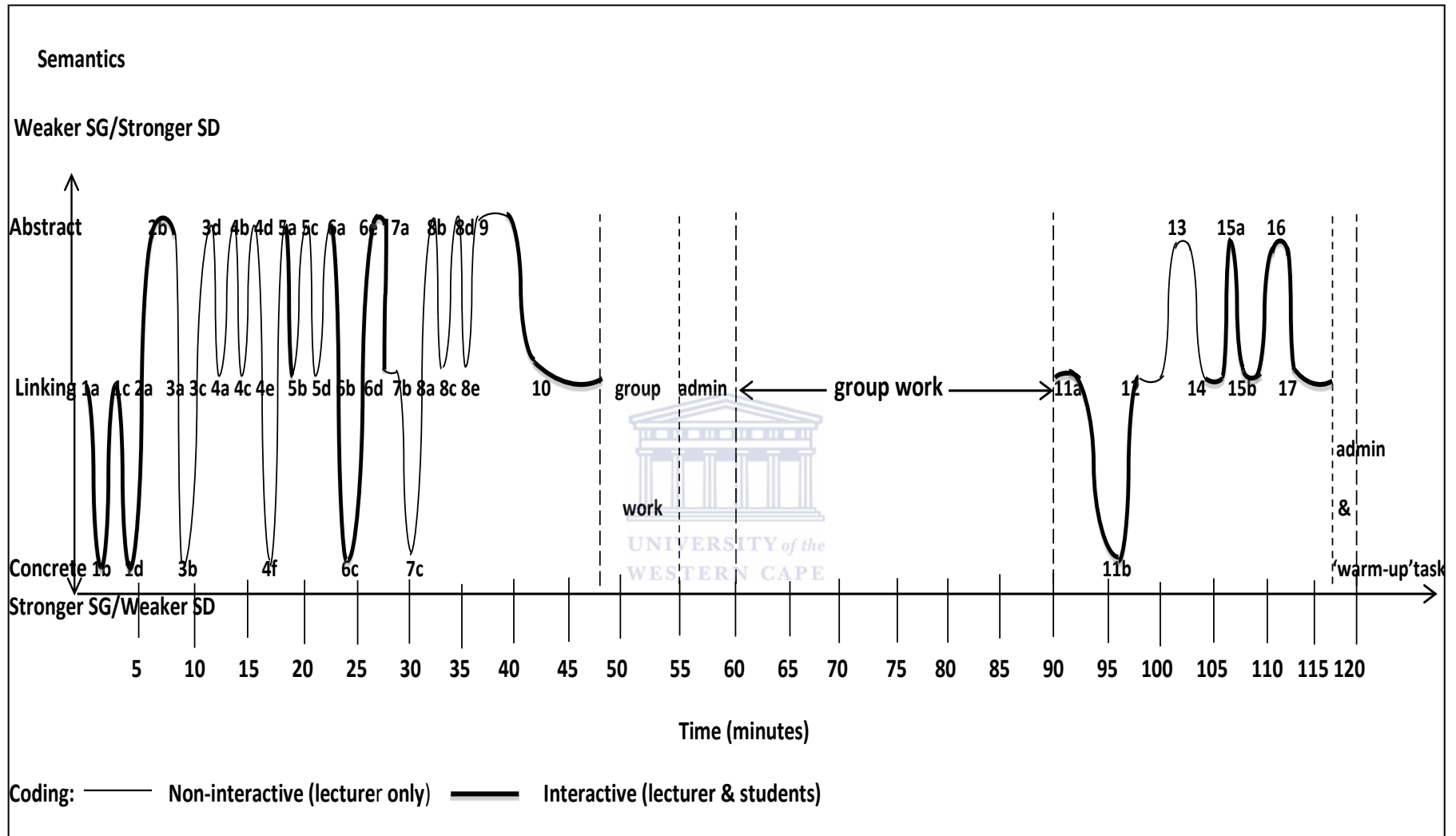


Figure 7.2: The semantic profile for the Extended lecture sequence 2 (Topic: Work-Energy)

### 7.2.2.2 Overview of Extended course lecture sequence 2

- In part 1, from 0 minutes to 4 minutes (*for 4 minutes*) (sequence of L – C – L – C): the lecturer asks the students: ‘Say anything you know about energy.’ He unpacks the words used by the students in their response (part 1a). He then uses a demonstration to respond to the request of a student to repeat the explanation (part 1b). Thereafter, the lecturer asks: ‘Anything else of energy?’ and the students respond with a definition of energy (part 1c). The lecturer unpacks this definition with an example (part 1d).
- In part 2, from 4 minutes to 8 minutes (*for 4 minutes*) (from C to L to A): the lecturer asks the students to read the definition of energy in their notes, before reading the definition out aloud himself. He then reminds them about the due date for handing in their chapter summaries (part 2a). The lecturer uses the definition from the notes, repacks the definition and writes the explanation of mechanical energy symbolically on the OHP. He uses the concept of gravitational potential energy to introduce the concept of conservative forces (part 2b).
- In part 3, from 8 minutes to 10 minutes (*for 2 minutes*) (sequence of A – L – C – L – A): the lecturer unpacks the concept of conservative forces (part 3a) and demonstrates this with an example (part 3b). He continues by repacking the example and showing how an object gains and loses energy (part 3c). Lastly, he explains the meaning of ‘conservative’ as meaning no net change in the total energy of the system (part 3d).
- In part 4, from 10 minutes to 16 minutes (*for 6 minutes*) (sequence of A – L – A – L – A – L – C): the lecturer unpacks the concept of ‘conservative force’, using a verbal example of a spring oscillating vertically, and draws a sketch of the spring on the OHP (part 4a). Thereafter, he condenses this example symbolically to show how the energy changes from one form to another (part 4b). He then uses another example of a spring that is being compressed or stretched horizontally, and shows in a sketch how the displacement ( $\Delta s$ ) changes with compression and extension (part 4c). He condenses this example symbolically on the OHP (part 4d) to show how elastic potential energy is related to  $\Delta s$ :  $U_s = \frac{1}{2}k(\Delta s)^2$ . The lecturer reminds the students about the first spring example, showing what happens when the spring is compressed or

stretched vertically (part 4e). He then demonstrates with another example of increasing and decreasing potential energy, by dropping a pen on the floor (part 4f).

- In part 5, from 16 minutes to 21 minutes (*for 5 minutes*) (sequence of C – A – L – A – L): the lecturer moves from the potential energy examples to the other type of mechanical energy – kinetic energy – and writes this symbolically on the OHP:  $K = \frac{1}{2}mv^2$  (part 5a). He thereafter relates this to other earlier topics in kinematics that they had covered, and gives a verbal example (part 5b). He then repacks the meaning of total mechanical energy in symbolic form:  $E_{mech} = K + U_s + U_g$  (part 5c). He thus relates these scalar quantities to the earlier Mechanics section on vectors and elaborates on this (part 5d).
- In part 6, from 21 minutes to 25 minutes (*for 4 minutes*) (sequence L – A – L – C – L – A): the lecturer introduces the concept of conservation of energy (part 6a). He asks: ‘Under what conditions do you think mechanical energy could be conserved in a system?’ After interaction with the students, he explores the meaning of ‘isolated system’ (part 6b). He thereafter demonstrates a box being pushed across a desk, sliding some distance, and coming to a stop. He asks why it stops and under which conditions the mechanical energy is conserved (part 6c). The students respond by linking the friction in the demonstration to the concept of the conservation of mechanical energy (part 6d). The lecturer uses this to introduce a new physics term (‘dissipative forces/agents’) to abstract from the demonstration (part 6e).
- In part 7, from 25 minutes to 30 minutes (*for 5 minutes*) (sequence A – A – L – C): the lecturer uses the terms isolated and non-dissipative systems and conserved kinetic energy to introduce the new concept of work done, before writing this symbolically on the OHP (part 7a). He uses a sketch to unpack the concept of work done, relating energy to the familiar concept of Newton’s 2<sup>nd</sup> Law (part 7b). He then uses a concrete example to demonstrate and explain the concept of work in terms of the interaction of particles within a system (part 7c).
- In part 8, from 30 minutes to 35 minutes (*for 5 minutes*) (sequence C – L – A – L – A – L): the lecturer repacks the example in terms of energy and work done (part 8a). The lecturer uses this relationship to introduce the concept of ‘dot

product', explaining this symbolically (part 8b). He furthermore explains the meaning of the dot product in terms of the units, writing this symbolically (part 8c). The lecturer explains the 'dot product' mathematically – as a mathematical symbol to express a vector operation and as a scalar product (part 8d) – and then unpacks the concept of 'scalar product' (part 8e).

- In part 9, from 35 minutes to 39 minutes (*for 4 minutes*) (from L to A): the lecturer uses a diagrammatic representation to condense the meaning of the dot product (part 9).
- In part 10, from 39 minutes to 48 minutes (*for 9 minutes*) (from A to L): the lecturer is explicitly linking the diagrammatic representation of the dot product to the same concept that was dealt with in the students' Mathematics course; he relates the mathematics in physics to students' understanding of vectors (part 10).

**[N.B. Class activity takes place here: 37 minutes (in the 7 last minutes of the first lecture, the lecturer gives students a problem task, and in the first 30 minutes of the second lecture, students had to finish the task in groups). The problem task is that of a passenger carrying a suitcase up a flight of stairs, with the students needing to calculate the work done by the passenger]**

- In part 11, from 90 minutes to 96 minutes (*for 6 minutes*) (from L to L to C): one group volunteers to write the solution of the task on the OHP. The lecturer moves around to look at the other groups' solutions, intervenes and addresses the whole class to ascertain their understanding of the task (part 11a). He asks the students questions about the task, before using a demonstration of carrying a suitcase to unpack the task (part 11b).
- In part 12, from 96 minutes to 100 minutes (*for 4 minutes*): (from C to L): the lecturer links the concrete demonstration of carrying a suitcase to the students' solution (the FBD) by drawing a sketch to show the initial and final state of the system.
- In part 13, from 100 minutes to 103 minutes (*for 3 minutes*) (from L to A): the lecturer uses the students' solutions (the FBD) to draw a sketch, in order to show the students how to identify the significant information in terms of the

relevant force, displacement and the angle between the two, and in order to explain in depth how to solve the task in terms of work done.

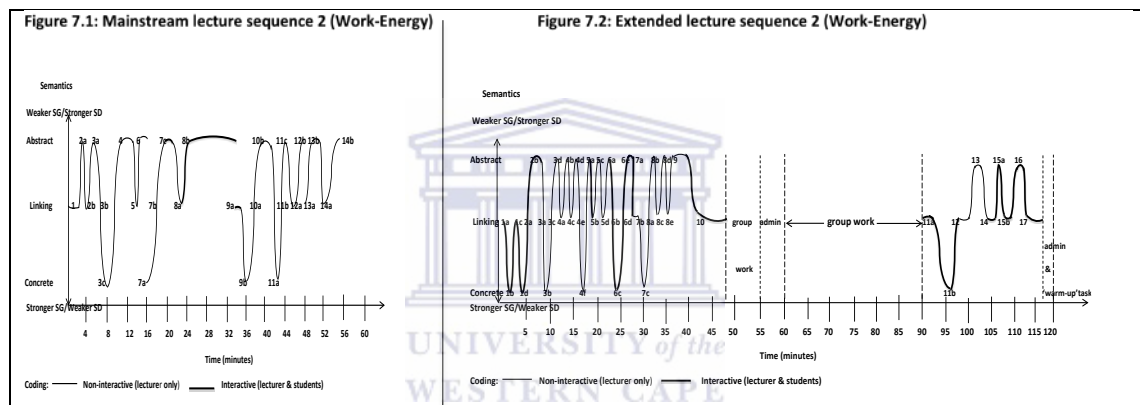
- In part 14, from 103 minutes to 106 minutes (*for 3 minutes*) (from A to L): the lecturer responds to a student's question with a verbal example, and emphasises the importance of superimposing the displacement vector and the angle when drawing a diagram for work done.
- In part 15, from 106 minutes to 109 minutes (*for 3 minutes*) (from L to A to L): the students are required to relate this new concept of work done to the first problem task question (part 15a). He then requests the class to read the question from the task ('how much work does the passenger do?'), before paraphrasing it and asking them which of the forces in their FBD is relevant for the question (part 15b).
- In part 16, from 109 minutes to 112 minutes (*for 3 minutes*) (from L to A): the lecturer repacks the students' responses and writes the solution symbolically:  $W_{\vec{F}_{\text{on } S}} = \vec{F}_{\text{on } S} \cdot \Delta\vec{r}$ ; (Here he is explicit about the notation used and clear about specifying the forces needed).
- In part 17, from 112 minutes to 117 minutes (*for 5 minutes*) (from A to L): the lecturer uses the diagram and the symbolic representation to answer the question from the task (to calculate the work done by the passenger); he asks probing questions, explains in-depth and solves the problem in using  $i$  and  $j$  notation. Finally, he ends the lecture by asking the students to solve the problem in component form at home.

The objective of this chapter was to observe another lecture sequence. This section (Section 7.2) has presented two detailed analyses of lecture sequence 2 from the Mainstream and Extended courses, in order to characterise the pedagogical practices, while a similar content knowledge – *Work-Energy* – was being taught. As part of the analysis, semantic profiles of the pedagogical practices were constructed. Section 7.3 below provides a summary of these semantic profiles of pedagogical practice.



### 7.3 Summary of analysis of semantic profiles of the Mainstream and Extended courses lecture sequence 2

Chapter 6 highlighted certain differences in the semantic profiles when *different topics* were being taught in the two courses. Therefore, this chapter examines whether the differences in semantic profiles were an artefact of the content knowledge being taught or an indication of different pedagogical practices. The semantic profiles for both courses have been presented in this chapter. In this section, the differences and the similarities between the two semantic profiles are discussed. Data extracts are also used to illustrate some of these differences and similarities.



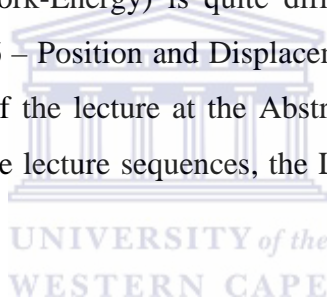
**Figure 7.3: Semantic profiles for the pedagogical practices in the Mainstream and the Extended lecture sequence 2**

The two semantic profiles presented in this chapter (shown side-by-side in Figure 7.3) are to a certain extent more similar than those given in Chapter 6, where the Extended semantic profile was very different from the Mainstream one. In both semantic profiles, there is frequent shifting between levels of SG and SD; moreover, these shifts in SG and SD are more compressed in this second Extended course lecture sequence than they are in the first one examined in Chapter 6. Despite the general similarities between the semantic profiles presented in Chapter 7, there are nevertheless several differences:

Firstly, the **entry and exit points** are different; although they both start at the Linking level, in the Mainstream course, the lecture moves immediately into a sequence of

Abstract-Linking shifts. In contrast, the Extended lecture moves immediately into a sequence of Linking-Concrete shifts. In terms of the exit points, the Mainstream lecture ends at the Abstract level (with a mathematical formulation of the Work-Energy theorem – part 14b), whereas the Extended lecture ends at the Linking level (with an interactive discussion of how a Work task is expressed in  $i$  and  $j$  notation – which students learnt about earlier in Mechanics – part 17).

Secondly, the semantic profiles show that the **proportion of lecture time spent at the levels of Abstract, Linking and Concrete** differs within the Mainstream and Extended course lectures. For the Mainstream course, the semantic profiles for lecture sequence 1 (Chapter 6) and 2 (Chapter 7) are very similar: there is roughly an equal proportion of the lecture at the Abstract and Linking levels, with a smaller proportion at the Concrete level. For the Extended course, the semantic profile for lecture sequence 2 (Chapter 7 – Work-Energy) is quite different to the Extended course lecture sequence 1 (Chapter 6 – Position and Displacement): in the second sequence, there is a larger proportion of the lecture at the Abstract level than at the Concrete level. In both Extended course lecture sequences, the Linking level forms the largest proportion of the lecture.



In comparing lecture sequence 2 for the Mainstream and Extended courses, the proportion of lecture time spent at the Abstract, Linking and Concrete levels differs. In the Mainstream lecture, there seems to be proportionally more time spent at the Abstract level, whereas in the Extended lecture, slightly more time is spent at the Concrete level.

The semantic profile for the Extended lecture sequence shows that the first lecture in the sequence (until  $t = 48$  minutes) is more similar to the Mainstream course than the second lecture in the sequence (from  $t = 60$  minutes to 117 minutes). In the second lecture, the students are given time to work independently, which is followed by student engagement, as student solutions are shared and discussed with feedback from the lecturer.

Thirdly, the **coding** on the semantic profiles again shows differences in terms of who is involved in the semantic shifts or moves between the Abstract, Linking and

Concrete levels. The Mainstream lecture is largely *non-interactive*; there is not much time for student engagement. At one point (part 7), the lecturer asks the students about the symbol for power (indicated by the thick line in part 7c); later, he sets up a problem and presents the representations needed for the problem (first a sketch, then a symbolic representation) on the board; the students are engaged only at the stage of substituting values into the symbolic representation (indicated by the thick line in part 8a–8b). The third occurrence of student engagement is when the lecturer asks ‘What is energy?’ (part 9). The students answer, ‘the ability to do work’. The lecturer writes their response on the board in a more precise way: ‘Energy – the ability a body possesses to do work’.

In contrast, the Extended lecture is more *interactive*, with much of the time being spent in student engagement with lecturer guidance (as shown by the thick line in the semantic profile). Even in the first part of the Extended semantic profile, which is very similar in shape to the Mainstream semantic profile, the coding shows that there is more student engagement. The lecture starts with student engagement, where the lecturer explores students’ prior knowledge of ‘energy’ (part 1) by asking ‘Say anything that you know about energy’. It is interesting to note that, in the Mainstream lecture, the definition of energy is dealt with rather quickly (part 9), whereas in the Extended lecture, the lecturer’s question about energy is followed by a series of shifts from Linking to Concrete level (part 1), and then to Abstract level (part 2).

Lastly, the semantic profile for the Mainstream lecture sequence shows that, in some parts, there are **discontinuities** between the shifts (6 & 7; 8 & 9). For instance, in parts 7 and 9, the lecturer will leave the concept previously dealt with and start with a new application without explicitly relating what he is currently doing to the theoretical concept dealt with earlier. This is not to suggest that there is no implicit link, but merely that this was not explicitly pointed out.

As with any analytical tool, there are certain aspects of the pedagogical practices, which the semantic profile cannot capture. In other words, there are subtle differences in the pedagogical practices of the Extended and Mainstream courses, which the semantic profile is, in a way, ‘hiding’. I will briefly discuss these below.

Firstly, the semantic profile does not reveal if the lecturer is **using teaching and learning materials** (*i.e. class handouts, course readers, their own summary notes or textbooks*), when there are semantic shifts between the Concrete, Linking and Abstract levels. In the Mainstream course, the lecturer writes notes on the board and makes no mention of the textbook, students' own notes or class notes (although summary notes are handed out at the end of each chapter). In the Extended course, in contrast, class notes and the textbook are often used as artefacts for scaffolding the semantic shifts. For example, in part 2, the lecturer asks students to look at the definition of energy in their printed notes, before unpacking the definition together with the students and relating it to an explanation of mechanical energy. He also refers here to students' 'chapter summaries': these are summaries of the textbook chapters that students are required to complete in preparation for the following lecture. Again, in part 10, he asks student to read the problem example from their class notes; this problem is then read out aloud and unpacked together. This is in contrast with the Mainstream course, where problem examples are given to students verbally and mainly set up by the lecturer (for example, see parts 8 and 13 of the Mainstream course lecture sequence 2). Later, the Extended course lecturer (in part 15) refers back to the written problem statement in the class notes and asks the class to reread the question: 'How much work does the passenger do? He then paraphrases the question: 'Which means, the work done by the force', and links this to the use and interpretation of the FBD. In summary, he is using the class notes as a means of scaffolding the semantic shifts: through unpacking and repacking the verbal and physical representations.

Secondly, the **use of examples** varies within and between the two courses. Broadly speaking, examples were either used as *concrete demonstrations/illustrations*, or as a form of a *verbal problem example*. If an example is used in a concrete way (as a demonstration or illustration) to introduce a new concept, or to relate a concept to a concrete real-life situation, then it is coded as Concrete (C). For example, the Mainstream course lecturer lifts up a book from the floor to demonstrate the concept of power (part 7); the Extended course lecturer introduces the concept of a dissipative force by means of a demonstration (part 6): a box is pushed across the desk, it slides some distance and he asks why it stops.

At other times, an example is used either to derive a new physical relationship or to apply a new physics concept. Here, the *verbal problem example* is used to build towards the abstract level, and so it is coded as Linking (L). For example, the Mainstream course lecturer gives a verbal example (in part 13) to apply the newly introduced Work-Energy theorem.

It is interesting to note, however, that not all illustrative examples are automatically coded as Concrete; the context is important. For example, both the Mainstream and the Extended course lecturers use the example of carrying a suitcase when explaining work done; however, these are coded differently because they are used differently. In the Mainstream lecture sequence 1 (Chapter 6, Table 6.1, part 2), the lecturer uses the example to illustrate the mathematical formulation of work done:  $W_F = \vec{F} \cdot \vec{s}$ . He illustrates the significance of the angle between the two vectors with the example:

*If you're carrying something, a bag or suitcase, the work done by you on the bag is zero, because you are going this way (indicating to the right) and of course you apply the force vertically upwards (indicates upwards). You were taught at school work is force times distance – that is wrong, that is the special case when work is force times distance*

Although the suitcase example is intended to relate the abstract definition of work done to a concrete example, it is taken for granted that students will see that the 'special case' taught at school becomes relevant when the angle between the two vectors is zero. Therefore this illustrative example is coded at the Linking level.

In the Extended course lecture, the suitcase example is also used to unpack a question in a task that some students are struggling to understand. The lecturer demonstrates how the suitcase is being carried in the problem task. While he does this, he poses questions to the students to contextualise the task:

*How are you carrying the suitcase? Is the suitcase's speed increasing? If you look at the state of energy – the suitcase's speed at the start and at the end – is it the same or not?*

In summary, the same illustrative example is coded differently, because the example is used differently: in the Mainstream lecture, the suitcase example is coded as

Linking, because it is only a brief description (0.5 min), which students need to interpret for themselves in order to recognise the relation to the mathematical definition of work done. In the Extended lecture, the same example is coded as Concrete, because the lecturer poses questions so that the students can discern the importance of the angle between the vectors and relate this to the concrete example (this takes 4 min).

Building on previously learned knowledge is a key aspect of cumulative learning (Maton, 2009). The third aspect that the semantic profile cannot capture is the details of **how prior knowledge is built upon**. For example, the profile cannot distinguish whether the prior knowledge is from an earlier part of the same lecture, from a previous lecture, from a related subject (e.g. Mathematics – vectors, integration), from school physics, or from wider everyday contexts. The semantic profile can indicate a transition between Concrete and Linking, or between Linking and Abstract, but it cannot show the details of this. Therefore, the summary data is important. Although both lecturers link to students' prior knowledge, how they do so is different. For example, both introduce the concept of 'energy' by posing questions to the students: the Mainstream course lecturer asks, 'What is energy?' (part 9). Conversely, the Extended course lecturer, introducing the same concept, asks, 'Say anything you know about energy?' The lecturer's more open-ended question invites a wider range of understandings of the concept of energy.

The Mainstream students answer, 'the ability to do work', and the lecturer writes their response on the board in a more precise way: 'Energy – the ability a body possesses to do work'. In response to the Extended course lecturer's question – 'Say anything you know about energy' – an Extended student also gives a definition: 'energy cannot be destroyed or created, but it can be transferred'. The lecturer contrasts the meaning in the words 'transferred' and 'transformed', using a demonstration. The lecturer then invites other understandings of energy and the students respond, 'energy is the ability to do work'; the lecturer then spends time elaborating on this definition: 'If I have energy in a system, that system has a capacity to do work on another system or object'.

Another interesting use of prior knowledge in explaining the mathematical definition of work done relates to the mathematical concept of the dot product. In the Mainstream lecture sequence 1 (Chapter 6, parts 2 & 7), the mathematical meaning of the dot is taken for granted; in the Extended lecture, in contrast, this is elaborated upon by explicitly linking it to the mathematical concept of ‘dot product’ (part 8), which is then illustrated both diagrammatically and symbolically (part 9), before being linked back to the physics example (part 10).

#### **7.4 Conclusion to Chapter 7**

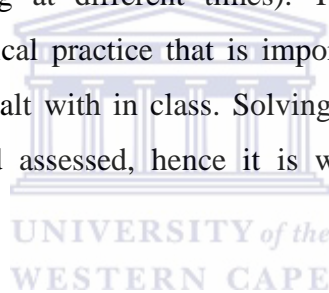
This chapter has examined two lecture sequences that have *similar content knowledge*. It was shown that, while these two lecture sequences were more similar than the ones in Chapter 6, key differences could be identified, such as, the entry/exit points, the semantic range, the compression of semantic profiles, the relative time spent at Concrete, Linking and Abstract levels, the discontinuities and the communicative approaches used. Chapter 8 will focus on a particular aspect of physics-related pedagogical practice, that is, how lecturers deal with physics problem tasks in class. Solving problems is a central way in which physics is taught and assessed, so Chapter 8 focuses on this particular aspect of pedagogical practice.

## Chapter 8:

### How Physics Problems are dealt with in Class

#### 8.1 Introduction

This chapter presents the analysis of the data relating to Research Question 1: *What is the nature of the Mainstream and Extended pedagogical practices, in terms of their semantic profiles (i.e. semantic gravity and semantic density)?* The previous two chapters presented the findings from classroom observations of the lectures in the Mainstream and the Extended courses. Chapter 6 looked at the pedagogical practices with the lecture sequences occurring at more or less the *same time during the academic year*, even though they were covering different content knowledge. Chapter 7, in contrast, examined two lecture sequences that had *similar content knowledge* (though occurring at different times). This chapter will focus on a particular aspect of pedagogical practice that is important in physics, namely, how physics problem tasks are dealt with in class. Solving problems is a central way in which physics is taught and assessed, hence it is worthwhile devoting an entire chapter to this.



In this chapter, I will investigate how the lecturers in the two classes dealt with physics tasks relating to Newton's 2<sup>nd</sup> Law. This topic was specifically selected because it is the topic of the task that the students were interviewed about during my subsequent data collection process (this will be discussed in Chapter 9). As I pointed out in Chapter 4, the motive behind this was to look at the same topic in the lectures as in the students' work, and moreover to look carefully at how the lecturers in class dealt with the same sort of Newton's 2<sup>nd</sup> Law problems.

This chapter has a strong methodological emphasis, as Chapter 6 also had, with the inclusion of data tables in order to demonstrate how the use of representations used in tackling a physics problem in class was analysed in terms of SG and SD. This close engagement with the data provides a form of 'audit trail', to allow the reader to follow the analytical process entailed in constructing the semantic profiles. As noted in Chapter 6, the data tables may seem very data-rich for the reader, but a simplified



overview of each lecture sequence is also given after the semantic profiles in Figures 8.1 and 8.2.

Section 8.2 below will present two detailed analyses of lecture sequence 3 from each course, focusing on how Newton's 2<sup>nd</sup> Law physics tasks are dealt with in class.

## **8.2 Detailed analysis of physics tasks involving Newton's 2<sup>nd</sup> Law from Mainstream and Extended course lectures**

This section presents two lecture sequences involving Newton's 2<sup>nd</sup> Law problem tasks: the Mainstream lecture sequence occurred during Term 2 and the Extended one during Term 3. In both cases, Newton's 2<sup>nd</sup> Law had already been taught, and so the lecturers were in a sense using it in the context of subsequent topics in the course. In the Mainstream course, Newton's 2<sup>nd</sup> Law was used to show that a problem that dealt with using Newton's 2<sup>nd</sup> Law could also deal with using Work-Energy considerations; in the Extended course, Newton's 2<sup>nd</sup> Law was being applied in the context of discussing Newton's 3<sup>rd</sup> Law.

As Kohl and Finkelstein (2006) note, the term 'problem' in physics education does not always imply or necessitate a quantitative analysis. They use the term to refer to 'typical physics tasks given to students', which would include questions that do not involve numerical calculations. Although in this case both problems required the application of Newton's 2<sup>nd</sup> Law, the two problem tasks analysed were slightly different: numerical values were given in the Mainstream course problem statement, whereas the Extended course problem built towards a mathematical representation of Newton's 2<sup>nd</sup> Law without inserting numerical values at the end.

### *8.2.1 How to interpret the data tables and semantic profiles below*

Firstly, both lecture sequences are independently presented in table form to highlight significant information about the use of representations in the way the Mechanics tasks are dealt with (as shown in Chapter 4). The data tables (Table 8.1 and Table 8.2) comprise six columns, which contain the following details:

- Column 1: numbered parts of the lecture sequence and the time taken;

- Column 2: the ideal representations, based on how a Mechanics problem would be expected to be dealt with (Knight, 2007; Van Heuvelen, 1991a);
- Column 3: a description of how the lecturer used specific representations in the physics tasks;
- Column 4: what was written on the board (words, sketches, diagrams, equations, etc.);
- Column 5: coding comments, which can be used to interpret the shape of the semantic profile and to indicate the form of communicative approach (interactive or non-interactive) employed in each part of the lecture sequence;
- Column 6: practices associated with the representations (e.g. read and unpack, model, visualise, etc.).

As discussed in the Methodology section (Chapter 4), each lecture sequence was broken down into several parts, for analytical purposes. This division was based on when a new representation was used; for example, part 1 could be a verbal representation (the reading and unpacking stage), whereas part 2 could involve modelling the problem (the model stage). These parts (together with the approximate time taken for each part) are labeled in Column 1 of the table.

The coding comments (Column 5), together with Column 6, can be used to interpret the shape of the semantic profile presented below. The shape of the profile is an indication of how the transitions take place between the semantic levels (whether quickly or gradually, depending on how much time is used for a specific representation). This last column (Column 6) summarises the position and the shifts in these representations.

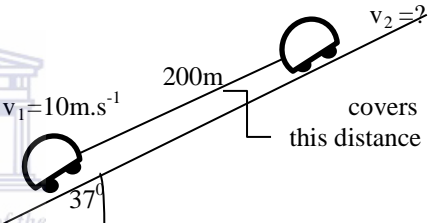
From this analysis, the semantic profile is constructed (for a reminder of how SG and SD are related to the representations used in physics problem tasks, see Figure 4.1 in Chapter 4). After the semantic profiles for the Mainstream and the Extended course lectures are presented, these are analysed in terms of their observed similarities and differences.

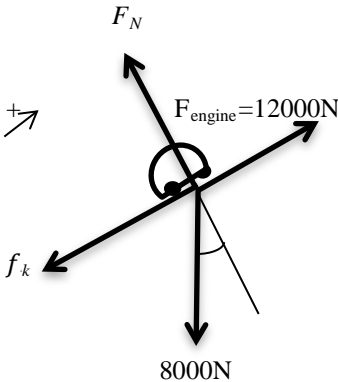
### 8.2.2 *Mainstream course lecture sequence 3 – Newton’s 2<sup>nd</sup> Law physics task*

In Table 8.1 below, the analysis of a physics task in the Mainstream course is presented in terms of the external LoD for SG and SD, as described in Chapter 4. In Figure 8.1, an overview of Table 8.1 is presented in the form of a semantic profile and a summary.



**Table 8.1: Mainstream lecture sequence 3: Tackling a Newton's 2<sup>nd</sup> Law physics task**

| Parts of the lecture and the time taken     | Expected or ideal representations for the physics task – (external LoD)   | How the lecturer uses representations in dealing with the physics task   | What is written on the board (i.e. words, sketches, diagrams, symbols, equations)   | Coding comments   | Position and shifts in the application of Newton's 2 <sup>nd</sup> Law |
|---|---|--|---|---|--|
| 1<br>1.5 minutes<br>(from 0 to 1.5 minutes) | <p><b>Verbal representation (written or words)</b></p> <ul style="list-style-type: none"> <li>- read the problem carefully</li> <li>- sketch the situation</li> <li>- identify the object of interest (the system)</li> <li>- draw a circle around the object of interest</li> <li>- identify the external objects or forces interacting with the system</li> </ul> | <ul style="list-style-type: none"> <li>- The lecturer verbally introduces an example of a car driving up the hill.</li> <li>- He describes the problem situation in words (verbally), saying, 'Let's say, you are driving a car up the hill and you are asked to find the velocity'.</li> <li>- He draws a sketch of the situation on the board. He writes in words and symbolically, as he talks through the whole sketch, he says, 'For example, the car covers 200m, the initial velocity is 10m.s<sup>-1</sup>, assume <math>\mu_k</math> is 0,2, etc.'</li> </ul> | <p>- The lecturer draws a sketch of the situation on the board.</p>  <p>let's assume friction <math>\mu_k = 0.2</math></p> | <p>Problem situation presented verbally</p> <p>He does not identify the system or the objects acting on the system.</p>                               | Reading & unpacking  |
| 2<br>(0 minutes)                            | <p><b>Pictorial representation (particle model)</b></p> <ul style="list-style-type: none"> <li>- represent the objects as a point particle</li> <li>- make simplifying assumption when interpreting the problem statement</li> </ul>  | <ul style="list-style-type: none"> <li>- The lecturer says, 'Here's the car', and draws a sketch of the car in the centre, as shown below in the physical representation.</li> </ul>   |   | <ul style="list-style-type: none"> <li>- The lecturer draws a figure of a car and does not represent the car as a dot or a point particle.</li> </ul> | Model  |

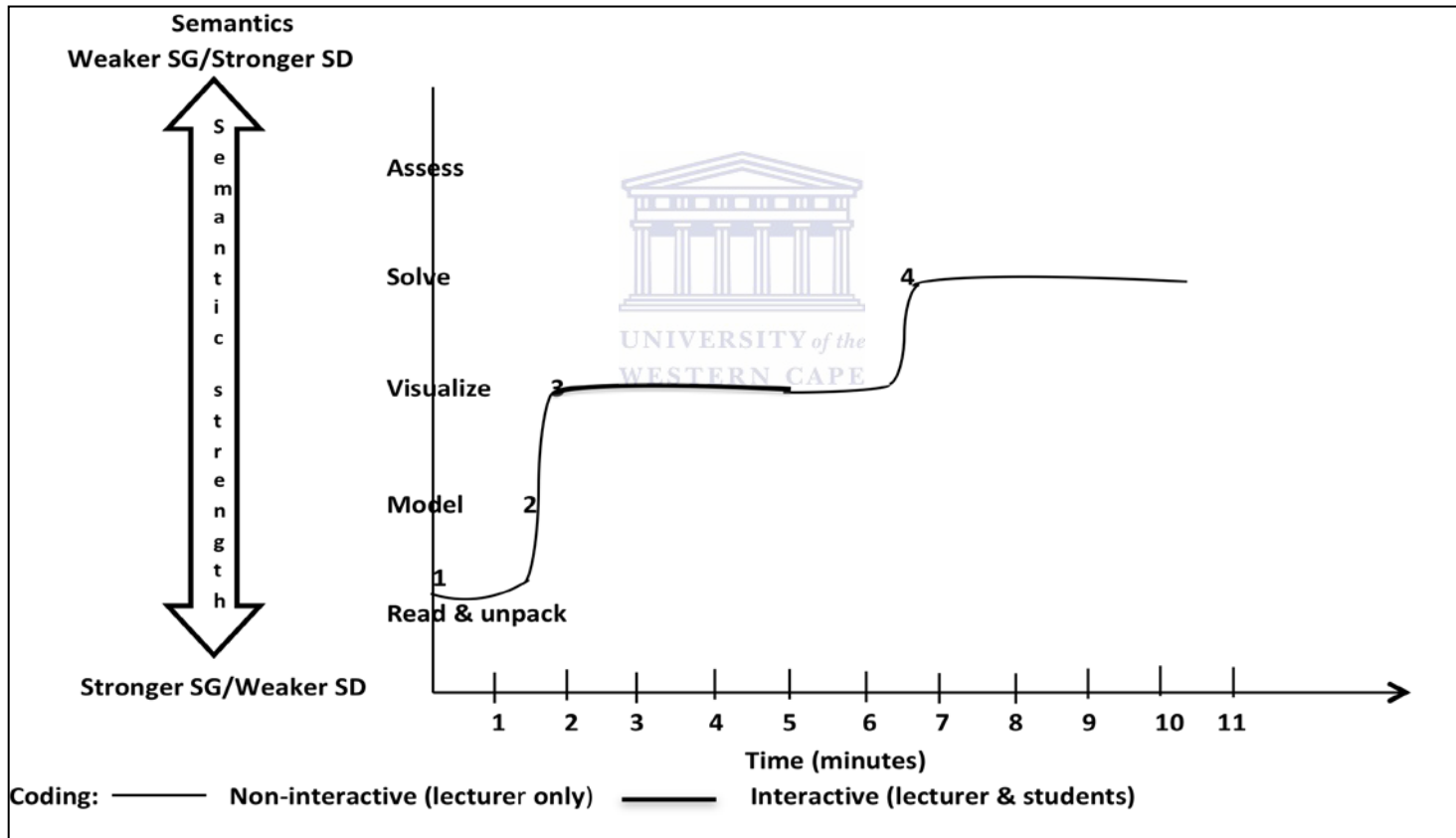
|   |   |  |   |  |                  |
|---|---|--|---|--|------------------|
| <p>3<br/>3.5 minutes<br/>(from 1.5 to 5<br/>minutes:<br/>students work<br/>on the task<br/>individually)</p> <p>1.5 minutes<br/>(from 5 to 6.5<br/>minutes: this<br/>time includes<br/>the<br/>modelling)</p> | <p><b>Physical representation (FBD)</b></p> <ul style="list-style-type: none"> <li>- identify all the forces acting on the object</li> <li>- establish a coordinate system to identify signs</li> <li>- represent the object as a dot at the origin of the coordinate axes</li> <li>- particle model</li> <li>- translate on the FBD the components for an inclined surface</li> <li>- draw force vectors representing all the identified forces (lengths represent the relative magnitudes)</li> <li>- label all the forces in the diagram (with two subscripts)</li> <li>- draw and label the vector <math>F_{net}</math> or the acceleration of the motion</li> <li>- translate the problem into symbols (define symbols for masses and for the interaction)</li> <li>- identify the desired unknowns</li> </ul> | <p>After drawing the sketch the lecturer gives the students time (3.5 min) to work on the problem, and guides them. He says, 'Of course you can solve this using Newton's 2<sup>nd</sup> Law; first find the acceleration, you say Nil, then use kinematics. Start by drawing a FBD of the car; how many forces are on the car?' Then he draws a FBD, as shown in the column on the right.</p> <p>As pointed out above, in the modelling stage, the lecturer says, 'Here's the car' and then draws a sketch of the car in the centre and gives the value for the mass of the car as 800kg.</p> <ul style="list-style-type: none"> <li>- Then, the lecturer identifies all the forces, and he says 'the most obvious one, <math>F_g</math>'. He firstly draws the gravitational force (<math>\downarrow 8000N</math>) straight downwards; secondly, he translates the angle <math>=37^\circ</math> on the diagram; then he draws the normal force (<math>\nearrow F_N</math>) perpendicular to an incline surface; thirdly, friction (<math>\swarrow f_k</math>) is shown as parallel to an inclined surface; and lastly, the applied force with the value (<math>\nearrow F_{engine} = 12000N</math>).</li> <li>- The lecturer says, 'If you want to find the resultant force, you need to decide some direction is positive, it's your choice. Let's</li> </ul> |  | <p>Here, students are given a chance to engage with the problem task for 3.5 min (see thick line coding on semantic profile)</p> <ul style="list-style-type: none"> <li>- the lecturer verbally names all the forces acting on the car</li> <li>- the lecturer draws force arrows (vectors) representing all the identified forces (with no details of the lengths of the vectors)</li> <li>- the lecturer translates onto the FBD the components for an inclined surface</li> <li>- the lecturer labels all the forces in the diagram with one subscript</li> <li>- the lecturer</li> </ul> | <p>Visualize</p> |
|---|---|--|---|--|------------------|

|  |  |  |   |   |       |
|--|--|--|---|---|-------|
|  |  | take up as positive, you can work out the resultant force acting on the body.' The lecturer then draws an arrow as (+ $\nearrow$ ) next to the diagram to show the direction of motion of the car that has been chosen to be positive.   |   | draws + $\nearrow$ besides the diagram to indicate the direction of motion of the car - then the lecturer identifies the desired unknowns                                   |       |
| 4<br>4 minutes<br>(from 6.5 to 10.5 minutes) | <b>Mathematical/quantitative representation (Newton's 2<sup>nd</sup> law)</b><br>- identify the law (first write the required law/equations for calculating the unknowns)<br>- find $F_{net}$ for the parallel sides and the perpendicular sides (the components for the inclined surface should be included in these sides)<br>- use explicit subscripts throughout this representation, each referring to a symbol that was defined in the physical representation/FBD<br>- replace the symbols with numerical values defined in the physical representation | - The lecturer tells the students that they must find the resultant force of the car. He asks: 'Which way is the resultant force acting on the car?' He answers by writing: 'up: $F_{net}$ – up the incline'.<br>- He says, 'So, I'll take this as my positive direction'. He then writes + $\nearrow$ and calculates the resultant force $F_{net}$ . He says, 'So let's write down the resultant force for up'. He begins: up: $1200 - f_k$<br>- The lecturer explains how $F_g$ can be broken down into components: 'This force here has two components, that one component (the horizontal component, next to $f_k$ ; this was not drawn on the board but indicated by hand where it should be in the diagram), this component is the same as that one (the side opposite angle $37^0$ )'.<br>- He writes the full equation for the number of forces acting along the surface,<br>up: $F_{res} = 1200 - f_k - 8000 \sin 37^0$<br>- Thereafter, the lecturer asks another question: 'How do we get | As shown above in the physical representation stage, the lecturer writes an arrow + $\nearrow$ to show the 'positive direction', as he writes, up: $F_{net}$ – 'up the incline'<br>The lecturer then writes down the resultant force for up the inclined direction as:<br>up: $1200 - f_k$<br>Then, he writes the full equation for the number of forces acting along the surface in the inclined direction:<br>up: $F_{res} = 1200 - f_k - 8000 \sin 37^0$<br>$F_N - 8000 \cos 37^0 = 0$<br><br>up: $F_{res} = 1200 - f_k - 8000 \sin 37^0$<br><br>- Then, the lecturer shows the students how to 'find $f_k$ ', writing the values that were implicitly calculated from finding the value for $F_N$ , (since $f_k = \mu_k F_N$ ):<br><br>$f_k = 0,2 \cdot 6400 = 1280N$ | - the lecturer identifies the law<br><br>- thereafter the lecturer finds $F_{net}$ resultant force<br><br>- lastly, the lecturer replaces the formula with numerical values | Solve |

|   |   |  |  |   |  |
|---|---|--|--|---|--|
|   |   | <p><math>f_k</math>?’ He says, ‘<i>We know that <math>f_k</math></i> (pointing at force <math>F_N</math> in the diagram), <i>how are you getting there?</i>’ He answers by saying, ‘<i>You look at the sketch</i> (meaning/pointing on FBD) <math>F_N</math> <i>must be balancing by this component of the weight</i> (pointing at the component perpendicular to the incline surface) <i>adjacent to the angle, then you say perpendicular</i>’:</p> $F_N - 8000 \cos 37^\circ = 0$ <p>then he puts the value in there,<br/>up: <math>F_{\text{res}} = 1200 - f_k - 8000 \sin 37^\circ</math></p> <p>He says, ‘<i>find <math>f_k</math></i>’, before writing the values,<br/><math>f_k = 0,2 \cdot 6400 = 1\,280\text{N}</math></p> <p>- Finally, he asks the students to find the acceleration <math>a</math> and gives them guidelines on how to work out this final part of the problem. He asks the students to finish the problem at home.</p> |  |   |  |
| 5 | <p><b>Assess the problem</b></p> <ul style="list-style-type: none"> <li>- check whether the result is reasonable</li> <li>- provide a final concluding statement wherein you interpret the mathematics solution in the context of the problem</li> <li>- check whether the result has correct proper signs and units</li> </ul> | No assessment has been done for this task  |  | No assessment has been done for this task by the lecturer |  |

8.2.2.1 Semantic profile of the Mainstream course lecture sequence 3

The shifts of the Mainstream course lecture in terms of SG and SD (which relate to the shifts between the multiple representations used) are presented in the form of a *semantic profile* (see Figure 8.1 below for this).





**Figure 8.1: The semantic profile for the Mainstream lecture sequence 3: Tackling a Newton's 2<sup>nd</sup> Law physics task**



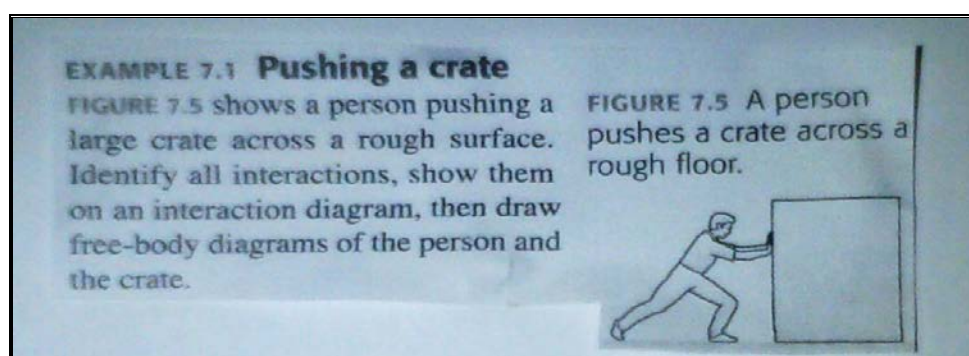
### 8.2.2.2 Overview of Mainstream course lecture sequence 3

- In part 1, from 0 minute to 1.5 minutes (*for 1.5 minutes*): **Verbal – Read & unpack**: the lecturer describes the problem situation verbally; system and agents not identified.
- In part 2 (*for 0 minutes*): **Modelling**: this representation is effectively skipped – the lecturer does not model the car as a point particle.
- In part 3, from 1.5 minutes to 6.5 minutes (*for 5 minutes*): **Physical – Visualise**: the lecturer gives students time to work on FBDs ( $t=1.5-5$  min); the lecturer thereafter proceeds to draw the FBD ( $t=5-6.5$  min), without drawing on the students' efforts.
- In part 4, from 6.5 minutes to 10.5 minutes (*for 4 minutes*): **Mathematics – Solve: identify & use NII**: the lecturer moves on to the mathematical representation of Newton's 2<sup>nd</sup> Law.

### 8.2.3 Extended course lecture sequence 3 – Newton's 2<sup>nd</sup> Law physics task

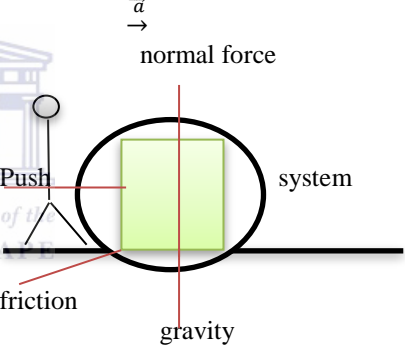
In Table 8.2 below, the analysis of a physics task in the Extended course is presented in terms of the external LoD for SG and SD in physics tasks, as described in Chapter 4. In Figure 8.2, an overview of Table 8.2 is presented in the form of a semantic profile and summary.

Unlike the Mainstream course, where the problem was presented verbally, here the physics task starts with an example from the textbook (see below).



Using this Newton's 3<sup>rd</sup> Law example as a starting point, the lecturer asks students to write a mathematical representation of Newton's 2<sup>nd</sup> Law for the crate, assuming that the crate has an acceleration to the right.

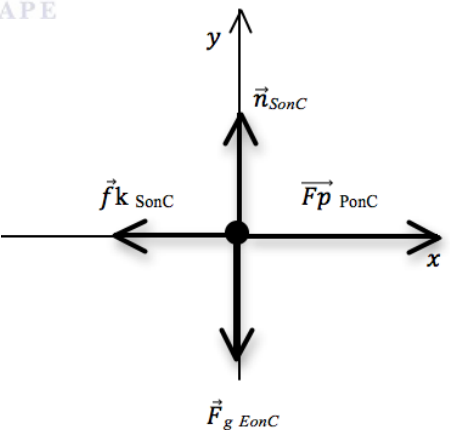
Table 8.2: Extended lecture sequence 3: Tackling a Newton's 2<sup>nd</sup> Law physics task


| Parts of the lecture and the time taken            | Expected or ideal representations for the physics task – (external LoD)   | How the lecturer uses representations in the physics task   | What is written on the board/OHP (i.e. words, sketches, diagrams, symbols, equations)   | Coding comments  | Position and shifts in the application of Newton's 2 <sup>nd</sup> Law |
|--|---|---|---|--|--|
| <p>1<br/>10 minutes<br/>(from 0 to 10 minutes)</p> | <p><b>Verbal representation (written or words)</b></p> <ul style="list-style-type: none"> <li>- read the problem carefully</li> <li>- sketch the situation</li> <li>- identify the object of interest (the system)</li> <li>- draw a circle around the object of interest</li> <li>- identify the external objects or forces interacting with the system</li> </ul> | <ul style="list-style-type: none"> <li>- The lecturer reads the example from the textbook of a person pushing a crate and the students look at their textbooks while he reads.</li> <li>- When translating the written words, he says: <i>'Start with a normal sketch.... identify the system (i.e. draw a circle around the object of interest); at this point start listing and labelling all the interacting objects or agents.'</i></li> <li>- While he is drawing the sketch, he asks questions and allows students to call out the answer. For example, he asks, <i>'With the crate, which objects or agents will interact with my system?'</i> The students answer, <i>'The crate'</i>. The lecturer says, <i>'Is the system'</i> and asks the class, <i>'What will we label it as?'</i> Students say <i>'C'</i>. He writes <i>'system – crate: C'</i>. The lecturer then asks, <i>'What next, what are the other systems, objects or agents, reactions that can identify the</i></li> </ul> | <p>The lecturer draws the sketch on the OHP:</p>  <p>system – crate: C      <math>\vec{F}_{p_{\text{PonC}}}</math></p> <p>agents { person: P      <math>\vec{n}_{\text{SonC}}</math></p> <p>          { surface: S      <math>\vec{F}_{g_{\text{EonC}}}</math></p> <p>          { earth: E      <math>\vec{f}_{k_{\text{SonC}}}</math></p> | <ul style="list-style-type: none"> <li>- the lecturer reads the physics task</li> <li>- the lecturer sketches the situation</li> <li>- the lecturer and the students identify the system</li> <li>- the lecturer draws a circle around the system</li> <li>- the lecturer and the students identify the agents and specify all the forces with two subscripts</li> </ul> | <p>Reading &amp; unpacking</p>   |

|  |  |   |  |  |  |
|--|--|---|--|--|--|
|  |  | <p><i>system?</i>' The class responds, but he asks one student to answer, the student says, 'The floor'. He writes that on the OHP, and says, <i>'I'm going to refer to that as the surface: S'</i>. The students continue to call out all the other interacting agents and he writes them down and asks the students to label them, e.g. <i>person: P, earth: E</i>, as shown in the next column, (in the sketch).</p> <p>- After that, the lecturer says, <i>'Identify the significant forces'</i>. The students call out 'friction' and he draws the force on the sketch, and asks <i>'What agent is responsible for that force?'</i> The students respond, <i>'The surface'</i>. The lecturer specifies each force precisely, with 2 subscripts. For example, <math>f_{k\text{son}C}</math>. He notes, <i>'It is a frictional force of the surface on the crate.'</i> The class continues to call out all the other significant forces and the lecturer draws and writes them down.</p> <p>- They call out 'gravity' and he writes 'gravity <math>\vec{F}_g</math>', and says, <i>'You should write the vector signs on top.'</i> He asks them to label it as required in the textbook, and says, <i>'It is the force F, of what on what? So I want us all to adopt this convention for this course, you write it like this, after you've</i></p> |  |  |  |
|--|--|---|--|--|--|

|  |  |   |  |  |  |
|--|--|---|--|--|--|
|  |  | <p>identified all the coordinate systems labels (pointing to the significant forces), <math>\vec{F}_{g \text{ EonC}}</math>. He says, 'gravitational force of the earth on the crate'. He asks, 'then, what next?' The students call out, 'normal force', and he draws and asks, 'You see, I'm drawing it from the surface, it's the pressure from the surface that causes this normal force. How would you label that?' The students call out, 'It's the surface on the crate' and then he writes it down, normal – <math>\vec{n}_{\text{SonC}}</math>.</p> <p>- He notes, 'Can you see what I'm doing explicitly here? I'm now not just labelling this as a normal and gravitational force, I'm identifying the agent which is the result or causes the force. So, in other words, the earth is responsible for this gravitational force on the system that is the crate' (pointing on <math>\vec{F}_{g \text{ EonC}}</math>). Then a student asks, 'In the normal force, is it not the crate on the surface?' The lecturer responds, 'No, the normal force is exerted by the surface on the crate. Remember when we identify our system, it is important to understand that we are trying to identify the forces acting <u>on the system</u>. Why is that important? Why are we not worried about the force of the crate on the surface?' The class answer, then one student says aloud, 'The floor is not the</p> |  |  |  |
|--|--|---|--|--|--|

|  |  |  |  |  |  |
|--|--|--|--|--|--|
|  |  | <p>system'. The lecturer affirms this:<br/> <i>'Correct, if I want to analyse the motion or the net force on the system, I only care about the force acting on the system; we'll come back to this in a second.'</i></p> <p>- He continues labelling the forces. He asks the students to label any other forces, and they call out, <i>'Pushing force'</i>. He asks, <i>'The force of what on what? What it is due to?'</i> The students respond, <i>'It's the force of the person on the crate'</i>, which he labels as <math>\vec{F}_{P \text{ on } C}</math>.</p> <p>- He says, <i>'This is a short version to identify the interaction of all the forces; the important thing is, for each and every force, there's an equal but opposite reaction force; so for each force, there's a Newton's 3<sup>rd</sup> Law pair; there can only be action-reaction between two objects; only two objects interacting with each other.'</i></p> |  |  |  |
|--|--|--|--|--|--|

|   |  |  |   |   |                  |
|---|--|--|---|---|------------------|
| <p>2<br/>5 minutes<br/>(First 5 minutes:<br/>from 10 to 15 minutes:<br/>students work on the task in their group)<br/>(They draw a FBD and the point particle is included in this time)</p> | <p><b>Pictorial representation (particle model)</b><br/>- represent the objects as a point particle<br/>- make simplifying assumptions when interpreting the problem statement</p>   | <p>- The lecturer asks students to work in their groups and draw a FBD for the crate.<br/>- The lecturer allows the students to work on their own in their groups.<br/>- After some time, he asks for volunteers from the groups; one group volunteers and writes their solutions on the OHP.<br/>- The group represents the system as the dot/particle in the middle of the coordinate system.</p>  | <p>- the students make assumption: model the crate as a point particle (draw a particle dot)</p>  | <p>Model</p>  |                  |
| <p>3<br/>5 minutes<br/>(7 minutes:<br/>from 15 to 22 minutes:<br/>students draw a FBD and modelling is included in this time)</p>   | <p><b>Physical representation (FBD)</b><br/>- identify all the forces acting on the object<br/>- establish a coordinate system to identify signs<br/>- represent the object as a dot at the origin of the coordinate axes – particle model<br/>- translate on the FBD the components for an inclined surface<br/>- draw force vectors representing all the identified forces (lengths represent the relative magnitudes)<br/>- label all the forces in the diagram (with two subscripts)<br/>- draw and label the vector <math>F_{net}</math> or the acceleration of the motion<br/>- translate the problem into symbols (define symbols for masses and for the interaction)</p> | <p>- While the students are busy in their groups, the lecturer reminds the whole class about the significant information when drawing a FBD.<br/><br/>- The lecturer says, 'Draw the FBD and remember when we were trying to do; what was the main thing? I know it was a coordinate system and all the details of it, but what was the main purpose of it?' (He asks the question of the whole class). The whole class responds, but he asks one student to answer: 'We were trying to identify the significant forces acting on the system.' The lecturer repeats this statement and adds: 'and the relative sizes of the forces, that is so obvious. But now we are going to use Newton' 3<sup>rd</sup> Third Law and</p> | <p>The FBD below is the solution from the volunteer group:<br/><br/> <math display="block">\vec{F}_{net} = \vec{a}</math> <math display="block">\vec{a} = 0 / \vec{F}_{net} = 0 \text{ in } y \text{ coordinate}</math>  </p> | <p>- the students establish a coordinate system and draw a dot at the origin of the coordinate system<br/><br/>- the students identify all the significant forces<br/><br/>- the students draw force arrows (vectors) representing all the identified forces (with details of the lengths of the vectors)</p> | <p>Visualize</p> |

|   |   |   |  |  |                     |
|---|---|---|--|--|---------------------|
|   | - identify the desired unknowns   | <p><i>use that law to identify which forces are acting on which objects and what the relative sizes are.</i></p> <p>- The lecturer tells the students to assume that the crate's acceleration is to the right (this is used to help students to estimate the sizes of the vectors). He thereafter guides the students on how to identify the laws, by explaining: <i>'By Newton 3 you identify the agents' reactions and by Newton 2, the relative sizes.'</i></p>  |  | <p>- the students label all the forces in the diagram with two subscripts</p> <p>- the students draw and label <math>F_{\text{net}}</math> net force vector and the acceleration of the motion besides the diagram for the <math>x</math> axis and indicate that <math>a = 0 / \vec{F}_{\text{net}} = 0</math> in <math>y</math> coordinate</p> <p>- the students translate the problem into symbols</p> |                     |
| 4<br>2 minutes<br>(from 22 to 24 minutes) | <p><b>Pictorial representation (particle model)</b></p> <p>- represent the objects as a point particle</p> <p>- make simplifying assumption when interpreting the problem statement</p> | - As shown above in the physical representation, while the volunteer group is drawing the FBD, the group makes a simplifying assumption about the motion of the crate, that it is only along the $+x$ axis (towards right hand side); no motion in the $y$ axis and the friction is in the opposite side of the motion.   |  | <p>- the students make assumption that in the <math>+x</math> axis, there is <math>\vec{a}</math> and <math>\vec{F}_{\text{net}}</math>; in <math>y</math> axis <math>a = 0 / \vec{F}_{\text{net}} = 0</math> and there is friction (<math>\vec{f}_k</math>) in the <math>-x</math> axis</p>   | Model               |
| 5<br>2 minutes<br>(from 24 to 26 minutes) | <p><b>Verbal representation (written or words)</b></p> <p>- read the problem carefully</p> <p>- sketch the situation</p>  | - While the volunteer group is still busy writing their solutions on the OHP, the lecturer asks the whole class to look at their diagrams. He   |  | - in the FBD, the lecturer requests the students to  | Reading & unpacking |



|  |  |  |  |   |       |
|--|--|--|--|---|-------|
|  | <ul style="list-style-type: none"> <li>- identify the object of interest (the system)</li> <li>- draw a circle around the object of interest</li> <li>- identify the external objects or forces interacting with the system</li> </ul> | <p>says, 'While he's (the volunteer student is) drawing the FBD, ask yourself these questions,</p> <ul style="list-style-type: none"> <li>• did you label your force vectors according to the agents and the system?</li> <li>• do you have a coordinate system?</li> <li>• did you indicate the acceleration and net force on the diagram?</li> <li>• did you use Newton's 2nd Law to figure out what the relative sizes of the vector arrows on the system must be?</li> </ul> <p>- The lecturer summarises: 'Because you need to remember the diagram is not just some lifeless thing, it must reflect the physical situation.'</p> |  | <p>check whether the information from the written words and sketch matches their labelling of the diagram in terms of Newton's 2<sup>nd</sup> Law</p> <p>- here, the lecturer requests the students to review the FBD diagram by unpacking and relating the details on it to the written words and the sketch as 'the physical situation'</p> |       |
| <p>6<br/>2 minutes<br/>(from 26 to 28 minutes)</p> | <p><b>Pictorial representation (particle model)</b></p> <ul style="list-style-type: none"> <li>- represent the objects as a point particle</li> <li>- make simplifying assumptions when interpreting the problem statement</li> </ul>  | <p>- The lecturer adds: 'in other words, it (the diagram) must contain the knowledge that you have about the system'.</p> <p>- The lecturer refers to an example of gravity to explain how to reason with Newton's 2<sup>nd</sup> law. He then demonstrates by dropping a ball and asks the class, 'What is it doing in terms of Newton's Laws?' The students answer, 'It is accelerating.' He asks, 'How do I calculate this acceleration?' and they answer, 'by Newton's 2<sup>nd</sup></p>  |  | <p>- here, the lecturer reminds the students by highlighting the significant information contained in the sketch and the FBD (dot/point particle) 'about the system'</p> <p>- here, the lecturer is showing the</p>   | Model |

|  |   |  |  |   |           |
|--|---|--|--|---|-----------|
|  |   | <i>Law</i> '.  |  | relationship between acceleration and Newton's 2 <sup>nd</sup> Law through a different example of an acceleration, that is more familiar to students. This is done in order for students to see the relevance of making assumptions about the motion of the crate |           |
| 7<br>3 minutes<br>(from 28 to<br>31 minutes) | <b>Physical representation (FBD)</b><br>- identify all the forces acting on the object<br>- establish a coordinate system to identify signs<br>- represent the object as a dot at the origin of the coordinate axes – particle model<br>- translate on the FBD the components for an inclined surface<br>- draw force vectors representing all the identified forces (lengths represent the relative magnitudes)<br>- label all the forces in the diagram (with two subscripts)<br>- draw and label the vector $F_{net}$ or the acceleration of the | - The lecturer goes back to the question from the textbook (above), simplifying it and showing how the law should be applied. He involves students by asking questions and simplifying it, as well as using the principles to make clear some of their understanding (see details in the following paragraphs).<br><br>- The lecturer lets the group finish writing and uses their solution to continue his lesson. The group does all that the lecturer mentioned above in part 5, representing the system as a particle in the middle of the coordinate system, etc. |  | - here, the lecturer reviews the students' FBDs to see whether the force vectors in the FBDs correspond to their application of Newton's 2 <sup>nd</sup> Law for the crate; he also uses the details from the FBD to relate to Newton's 3 <sup>rd</sup> Law       | Visualize |

|  |  |   |  |   |              |
|--|--|---|--|---|--------------|
|  | <p>motion</p> <ul style="list-style-type: none"> <li>- translate the problem into symbols (define symbols for masses and for the interaction)</li> <li>- identify the desired unknowns</li> </ul>  | <ul style="list-style-type: none"> <li>- The lecturer uses the group's solution to emphasise why it is important to do as the group did, as mentioned in the previous paragraphs; he says, '<i>we only want you to draw a FBD for the crate</i>'.</li> <li>- The lecturer thereafter reviews the solution and asks the rest of the class to work in pairs: '<i>Talk to one another and explain why the sizes of the forces are equal or different. Also look whether the forces are Newton's 3<sup>rd</sup> Law pairs or not. Also, use the labels of the forces and look at their reaction-pairs and the acceleration or the net force of the motion.</i>'</li> </ul>  |  |   |              |
| <p>8<br/>4 minutes<br/>(from 31 to<br/>35 minutes)</p> | <p><b>Mathematical/quantitative representation (Newton's 2<sup>nd</sup> Law)</b></p> <ul style="list-style-type: none"> <li>- identify the law (first write the required law/equations for calculating the unknowns)</li> <li>- find <math>F_{\text{net}}</math> for the parallel sides and the perpendicular sides (the components for the inclined surface should be included in these sides)</li> <li>- use explicit subscripts throughout this representation, each referring to a symbol that was defined in the physical representation/FBD</li> <li>- replace the symbols with numerical values defined in the physical representation</li> </ul> | <ul style="list-style-type: none"> <li>- The lecturer uses the students' responses for a feedback session. He emphasises that the relative sizes of the forces give information about the acceleration. He uses the information from the FBD, writes it down and points out that, '<i>in the physical and mathematical representations</i>', e.g.<br/> <math display="block">\text{N11: } \sum \vec{F}_y = \vec{n}_{\text{SonC}} + \vec{F}_{\text{g EonC}} = 0</math> <i>(a = 0 / <math>\vec{F}_{\text{net}} = 0</math> in y coordinate)</i><br/> He says, '<i>write this in terms of the vector equation, the sum of the forces in the y direction</i>',<br/> <math display="block">\text{N11: } \sum \vec{F}_x = \vec{f}_{\text{kSonC}} + \vec{F}_{\text{PonC}} = m\vec{a}_x</math> He says, '<i>explicitly use the law to explain why the forces are equal or different</i>'; '<i>communicate</i></li> </ul> | <ul style="list-style-type: none"> <li>- The lecturer writes this on the OHP:<br/> <math display="block">\text{N11: } \sum \vec{F}_y = \vec{n}_{\text{SonC}} + \vec{F}_{\text{g EonC}} = 0</math> <i>(a = 0 / <math>\vec{F}_{\text{net}} = 0</math> in y coordinate)</i><br/> <math display="block">\text{N11: } \sum \vec{F}_x = \vec{f}_{\text{kSonC}} + \vec{F}_{\text{PonC}} = m\vec{a}_x</math> </li> </ul> | <ul style="list-style-type: none"> <li>- here, the lecturer uses the students' solution to recap and show them how to identify the law</li> <li>- the lecturer shows the students how to find <math>F_{\text{net}}</math> resultant force</li> <li>- the lecturer recaps and shows the students how to put significant information in the formula to</li> </ul> | <p>Solve</p> |

|   |   |  |  |   |  |
|---|---|--|--|---|--|
|   |   | <i>explicitly the piece of critical information that will tell the reason why the arrows are not equal in x direction'.</i>  |  | use and refer it to the explicit symbols defined in the FBD |  |
| 9 to 10<br>1 minutes<br>(from 35 to 36 minutes) | <b>Assess the problem</b><br>- check whether the result is reasonable<br>- provide a final concluding statement wherein you interpret the mathematics solution in the context of the problem<br>- check whether the result has correct proper signs and units | - This problem does not have numerical values but the lecturer tells the students to evaluate the mathematical representation of Newton's 2 <sup>nd</sup> Law in terms of the forces represented in the FBD. He points out that students should <i>'explicitly link the acceleration via Newton's 2<sup>nd</sup> Law to the conclusion of how the forces must be and what their relative sizes must be and their directions'</i> |  |   | - the lecturer tells the students how to evaluate the final solution |

### 8.2.3.1 Semantic profile of the Extended course lecture sequence 3

The shifts of the Extended course lecture in terms of SG and SD (which relate to the shifts between the multiple representations used) are presented in the form of a *semantic profile* (see Figure 8.2 below for this).

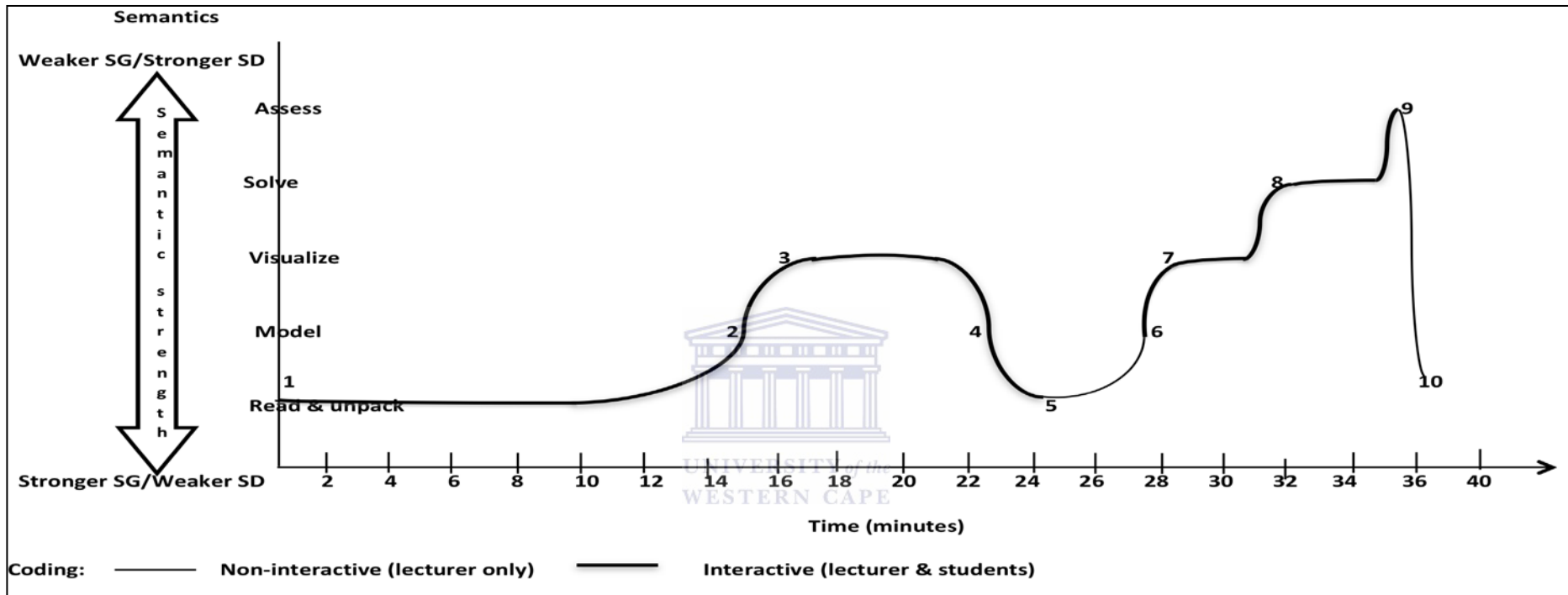


Figure 8.2: The semantic profile for Extended lecture sequence 3: Tackling a Newton's 2<sup>nd</sup> Law physics task

### 8.2.3.2 Overview of Extended course lecture sequence 3

- In part 1, from 0 to 10 minutes (*for 10 minutes*): **Verbal – Read & unpack**: the lecturer and the students read and unpack the written example; the system is identified, as well as the agents exerting forces on the object of interest.
- In part 2, from 10 minutes to 15 minutes (*for 5 minutes*): **Modelling**: the students work on the FBD, model the crate as a point particle, then draw force vectors; one student group volunteers to draw their FBD on the board.
- In part 3, from 15 minutes to 22 minutes (*for 7 minutes*): **Physical – Visualise**: the students work on their FBDs, while the lecturer prompts the students to check their FBDs and to relate the relative sizes of the force vectors back to the physical situation of the accelerating crate.
- In part 4, from 22 minutes to 24 minutes (*for 2 minutes*): **Modelling**: the students make simplifying assumptions about the motion of the crate: the system is not accelerating; the acceleration for the crate is equal to zero ( $\vec{a} = 0$ ), and therefore the resultant force is also zero ( $\vec{F}_{\text{net}} = 0$ ).
- In part 5, from 24 minutes to 26 minutes (*for 2 minutes*): **Physical – Visualise**: the lecturer requests the students to review the FBD to relate it to the details of the sketch and the problem statement.
- In part 6, from 26 minutes to 28 minutes (*for 2 minutes*): **Modelling**: the lecturer shows the relationship between the acceleration and Newton's 2<sup>nd</sup> Law through a different example that is more familiar to the students.
- In part 7, from 28 minutes to 31 minutes (*for 3 minutes*): **Physical – Visualise**: the lecturer reviews the students' solutions (FBDs) and gets them to check whether the sizes of the force vectors are reflecting the information about the acceleration and  $\vec{F}_{\text{net}}$ .
- In part 8, from 31 minutes to 35 minutes (*for 4 minutes*): **Mathematics – Solve: Identify & use NII**: the lecturer uses the students' FBDs to show them how to represent Newton's 2<sup>nd</sup> Law mathematically.
- In part 9 to 10, from 35 minutes to 36 minutes (*for 1 minute*): **Assess the problem**: the lecturer shows the students how to evaluate the problem situation.

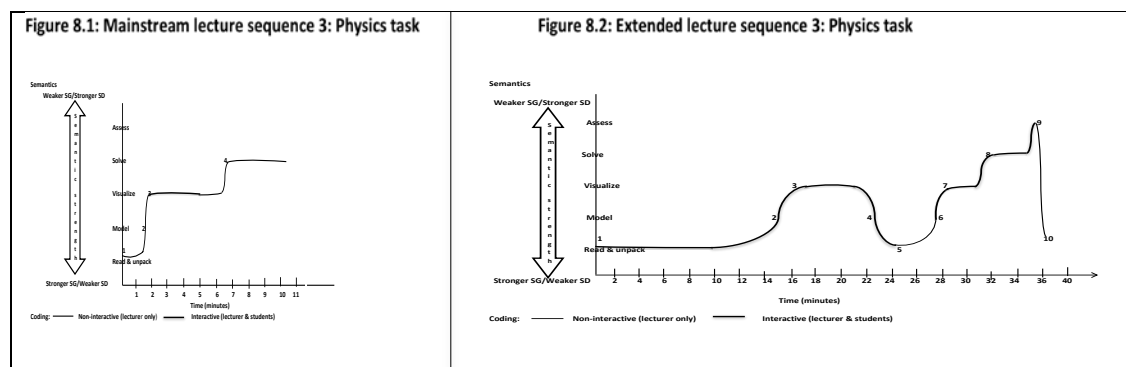
This section (Section 8.2) has presented two detailed analyses of lecture sequence 3 from the Mainstream and Extended courses, focusing on how Newton's 2<sup>nd</sup> Law physics tasks are dealt with in class. As part of the analysis, semantic profiles of the pedagogical practices were constructed. Section 8.3 below provides a summary of these semantic profiles of pedagogical practice.

### 8.3 Summary of analysis of semantic profiles of pedagogical practice

This chapter presents an analysis of the classroom observations from the lecture sequence 3 in the Mainstream and the Extended courses; during this sequence, the lecturers deal with a problem task relating to Newton's 2<sup>nd</sup> Law. Consequently, the semantic profile is used as an analytical tool to show the shifts between the various representations. The data reveals where the shifts occur between representations on the semantic continuum, as well as highlighting the different modes of interaction between lecturers and students in the classroom.

#### 8.3.1 The semantic profiles of pedagogical practices at a glance

The analysis of the two lecture sequences in the Mainstream and the Extended courses are shown in Figures 8.1 and 8.2 (shown side-by-side in Figure 8.3), which reveal how SG and SD vary over time. The steepness of the semantic profiles shows whether the movement up and down the semantic continuum is gradual or swift. The line thickness coding indicates the communicative approaches that are evident at various stages in the lecture.



**Figure 8.3: Semantic profiles for the pedagogical practices in the Mainstream and the Extended lecture sequence 3**

At a glance, the two lecture sequences reveal rather different semantic profiles. In the Mainstream course lecture sequence (Figure 8.1), there is a more rapid unidirectional shift up the semantic continuum, weakening SG (through a rapid shift away from the concrete problem situation) and strengthening SD (with the meaning of the problem context rapidly being condensed into mathematical representation). In the Extended course lecture sequence (Figure 8.2), in contrast, the semantic profile is initially flatter. While the Mainstream course lecturer takes about 6.5 minutes (from  $t=0$  minute to  $t=6.5$  minutes on the semantic profile) to move from introducing the problem situation to a completed FBD, in the Extended course, this same process takes about 31 minutes (from  $t=0$  minute to  $t=31$  minutes). The extra time in the Extended course is used for a more explicit focus on modeling the problem, and on the detailed aspects of constructing a FBD, before moving on to the mathematical representation. The semantic profile also shows more up and down shifting between representations in the Extended course.

### 8.3.2 *The semantic profiles in terms of ‘communicative approaches’ used in the lectures*

As noted earlier in the thesis (in Chapter 2), the modes of interaction in the lecture sequences were moreover characterised in terms of an analytical framework of ‘communicative approaches’ in science teaching, as developed by Mortimer and Scott (2003). This framework characterises communication as *interactive* or *non-interactive*. On the semantic profiles (Figures 8.1 and 8.2), the thick line represents interaction (viz. students and lecturer are engaged), while the thin line represents non-interaction (viz. the lecturer talks).

Mortimer and Scott (2003) moreover note that, within the ‘interactive’ category, communication may be *authoritative* (in a question and answer format) or *dialogic* (probing, elaborating, supporting, and building on students’ ideas).

The line thickness coding in the two semantic profiles indicates that there are much more interactive modes of communication in the Extended course lecture sequence than in the Mainstream course. On the Mainstream course’s semantic profile (Figure 8.1), there is a period of about 3.5 minutes (indicated by the thick line), when



the lecturer asks the students themselves to work on drawing a FBD and solving the problem. However, he does not then draw on their responses, but continues to demonstrate the solution on the board. This is a form of *authoritative* interaction (a variation of a ‘question and answer’ format). At other times in the Mainstream course lecture, the lecturer will pose a question to the class, but will immediately answer it himself. For example, when writing Newton’s 2<sup>nd</sup> Law in mathematical form (see Table 8.1, part 4), he asks the class, ‘Which way is the resultant force acting on the car?’ He then answers the question himself, writing on the board: ‘up:  $F_{net}$  up the incline’.

In contrast, the semantic profile of the Extended course lecture sequence (Figure 8.2) indicates that an interactive mode of communication approach is more dominant (as indicated by the thick line). The lecturer engages with the students in first reading the problem statement, and thereafter setting up the sketch, FBD, and mathematical representations together. The form of interactive mode here is *dialogic*, with the lecturer probing and building on students’ ideas. For example, when specifying the forces acting on the crate (see Table 8.2 part 1), the following dialogic interaction is observed:

*Lecturer: ‘Which objects and agents will interact with my system, the crate?’*

*Students: ‘The person, the floor, the Earth’ (as students respond, the lecturer writes these down – ‘person (P), surface of the floor (S), Earth (E)’)*

*Lecturer: ‘So now we need to identify the significant forces’ (the students call these out – ‘friction’, ‘gravity’ – and each time the lecturer probes the students: ‘it’s the force of what on what?’)*

*Lecturer: ‘Then, what next?’*

*A student: ‘Normal force.’*

*Lecturer: ‘You see, I’m drawing it from the surface, it’s the pressure from the surface that causes this normal force. How would you label it?’*

*Students: ‘The surface on the crate’ (lecturer writes ‘normal -  $n_{SonC}$ )*

*Lecturer: 'Can you see what I'm doing explicitly here? I'm now not just labelling this as a normal force... I'm identifying the agent, which causes the force.....'*

At two stages of the Extended course lecture sequence, there are sections coded as *non-interactive* (see Figure 8.2, part 5 to 6 and part 9 to 10). In these sections, the lecturer is providing a summary to the students of what has gone before. In parts 5 to 6, for instance, he is summarising the key elements in a FBD and explaining how a FBD relates to the physical situation it represents. In parts 9 to 10, he shows the students how to evaluate a problem situation.

### *8.3.3. Similarities and differences in the use of representations in tackling a physics task*

The analysis suggests that the lecturers in the two courses do not put an emphasis on the same aspects when tackling the physics task. In the discussion below, I will elaborate on the similarities and differences at the various stages of dealing with the physics task relating to Newton's 2<sup>nd</sup> Law.

#### *8.3.3.1 How the problem is introduced and set up (read and unpack)*

As shown in the data, the Mainstream lecturer gives the students a problem example by describing it *orally*, and then he draws a sketch of that situation on the board. The students have to listen to his description and look at the sketch to answer the questions that are being asked *orally*. Here, in class, students do not do the translation from the verbal representation to the sketch (pictorial representation) themselves. In contrast, in the Extended class, the lecturer reads the problem from the textbook with the students, and unpacks the *written problem statement* together with them, guiding them to draw the sketch and to identify both the object of interest and the interacting objects.

There is also a difference in the timing of when the interacting objects or agents are identified. In the Extended course, the agents are identified early on, during the pictorial representation stage, in which the sketch of the situation is drawn. The agents are first listed, then symbols for these agents are chosen, and then the force associated with those agents is identified and labelled with double subscripts, e.g. Crate – C –

$F_{\text{PonC}}$ . In contrast, in the Mainstream problem example, there is no explicit focus on agents, but the forces are identified only later, during the process of drawing the FBD. The meaning of identifying the agents or the forces seems quite different in the two cases. In the Extended course, it is at the concrete level of first identifying the agents that are interacting with the system, so that the forces can be identified and then represented symbolically. In the Mainstream course, by comparison, the forces are represented directly on the FBD (physical representation). Using the lens of SG, one can see that, in the Mainstream course, SG is weakened quickly; there is a rapid abstraction away from the problem context to the physical representation of this. Conversely, in the Extended course, the focus remains on the concrete level for longer – here, the agents are identified before abstracting to represent the forces on the FBD.

In the Extended course lecture sequence, right from the outset, the textbook is referred to, and the lecturer explicitly reminds the students of the symbolic representation of forces that is used in the textbook: he says, ‘*it is the force  $F$ , of “what” on “what”?* So I want us all to adopt this convention for this course; you write it like this, after you’ve identified all the coordinate systems labels (pointing to the significant forces),  $\vec{F}_{g \text{ on } C}$ ’.” He adds, ‘*gravitational force of the earth on the crate*’. In contrast, in the Mainstream course, the symbolic representation of the forces is not explicitly focused on.

This initial stage of reading and unpacking the problem statement took 16 minutes in the Extended course, and less than 2 minutes in the Mainstream course.

### 8.3.3.2 From the verbal representation to a FBD (model the situation)

Here, the Extended lecturer stresses the detailed particulars that students are required to know when translating the problem statement in order to draw a ‘*normal sketch*’, to identify the object of interest (i.e. the system) and to label both the system and the interacting objects (agents). His instruction to ‘*start with a normal sketch*’ emphasises the distinction between a sketch or *pictorial* representation of the situation, and a FBD, which is a modelled, *physical* representation of the situation. As noted in the discussion of the external LoD in Chapter 4, when modelling the problem or translating the verbal representation into a physical representation, one needs to make

certain simplifying assumptions and to model the object as a point particle. This demonstrates a clear distinction between what is called a *sketch* (or pictorial representation) and a *diagram* (or physical representation) in physics. As pointed out in the textbook (Knight, 2007), which both courses use, a point particle is a simplified version of treating the mass of an object as concentrated in a single point, where this mass of an object is considered as a particle that has no size, no shape and no distance between top and bottom or between front and back. This modelling process is regarded as a very significant assumption in physics generally.

The data indicates that the point particle is used differently in the two courses. The Extended lecturer asks students to draw a FBD of the crate, and the students themselves represent the system as a point particle in the middle of the co-ordinate system (Table 8.2, part 2). Here, the students interpreted the information from the written problem statement and from the lecturer's '*normal sketch*' and treated the mass of the crate as a single point particle. In contrast, the Mainstream lecturer does not represent the car as a point particle (Table 8.1, parts 2 and 3); instead, he draws a sketch of a car, and then the force vectors are drawn directly onto the sketch of the car. It should be noted that, in some of the other problem tasks observed during the lectures, the Mainstream lecturer did in fact use the particle model when drawing a FBD. However, in these cases, the lecturer did not explicitly emphasise the modelling implied by representing an object as a point particle.

As shown above, the modelling procedure is a transitional stage between the verbal and the physical representations, since it is used to visualize the object that is part of the setting in a problem statement to form part of a new representation, the FBD. In terms of Semantics, it is an important step in weakening the SG, by abstracting from the concrete situation to a more abstracted representation, and by strengthening SD, in that the modelling assumptions are condensed in the point particle representation.

#### 8.3.3.3 *Constructing the physical representation – the FBD (visualise)*

The analysis moreover looked at how the lecturers use FBDs when applying Newton's 2<sup>nd</sup> Law in their teaching. For instance, the Mainstream lecturer sets up the

FBD for students (see Table 8.1, part 3). He identifies all the forces, starting with the gravitational force: *'the most obvious one,  $\vec{F}_g$ '*.

In contrast, the Extended lecturer has already identified the system and all the forces of the interacting agents right at the outset (see Table 8.2, part 1), when reading and unpacking the verbal representation (see section 8.3.3.1 – *How the problem is introduced and set up*). When he asks the students to identify the significant forces, a student calls out 'gravity'; the lecturer thus writes 'gravity  $\vec{F}_g$ ' and points out the vector sign on top. He then elaborates (Table 8.2, part 1):

*It's the force of what on what?... It's the gravitational force of the Earth on the crate – that's  $\vec{F}_{g\ EonC}$ '... Can you see what I am doing explicitly here? I'm not just labeling this as the gravitational force. I'm identifying the agent, which is the result or causes this force. So, in other words, the Earth is responsible for this gravitational force on the system that is the crate (pointing at  $\vec{F}_{g\ EonC}$ ').*

It is interesting to note that, whereas in the Mainstream lecture, the dense symbolic representation,  $\vec{F}_g$ , is taken for granted (*'the most obvious force is  $\vec{F}_g$ '*), in the Extended lecture, there is more time to fully unpack the meaning condensed in the symbol  $\vec{F}_g$ . In LCT terms, the lecturer is explicitly weakening the SD of the symbol  $\vec{F}_g$ .

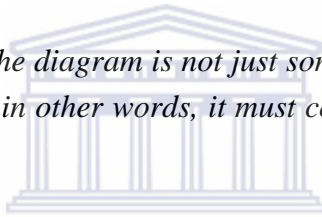
The Mainstream lecturer then goes on to identify and draw all the required force vectors but represents these forces with no details of the lengths for the vectors. He labels all the forces in the diagram with *one subscript* and translates on the FBD the components for an inclined surface. He draws + ↗ to indicate the positive *x*-direction (motion of the car). He furthermore identifies the desired unknowns. Here, although the lecturer has given the students time to work on the task individually (from 1.5 – 5 min, as represented by the thick line segment on the semantic profile), he does not draw on their answers in the subsequent exposition of the task on the board (as shown in Table 8.1, part 3).

In contrast, the Extended lecturer asks the students to draw a FBD themselves. As the students work in groups, drawing their FBDs, the lecturer reminds them (see Table 8.2, part 3):

*Remember, when we were doing the FBD, what was the main purpose of it? ... We were trying to identify the significant forces acting on the system ... and the relative sizes of them.*

He asks volunteers to write their solution on the OHP. The volunteer group draws a detailed FBD: they draw a coordinate system, model the object as a point particle at the origin of the coordinate system, and draw all the significant force vectors, taking care with the relative sizes of the vectors and labelling these with two subscripts. Next, they draw and label the  $F_{\text{net}}$  vector and the acceleration vector alongside the diagram for the  $x$  axis; they indicate that  $a = 0 / \vec{F}_{\text{net}} = 0$  for the  $y$  axis. Whilst this group is still busy drawing the FBD on the OHP, the lecturer requests the whole class to check their own work (FBDs), and to see whether they have done the same as the volunteer group has done (see Table 8.2, part 5). Here, the lecturer reminds the students of the purpose of a FBD:

*You need to remember the diagram is not just some lifeless thing; it must reflect the physical situation... in other words, it must contain the knowledge you have about the system.*



In these extracts, I can see evidence of a more explicit focus in the Extended course on the actual techniques of constructing the qualitative representations (the pictorial and physical representations, such as the FBDs) needed for successful quantitative problem-solving. There is also evidence here of the lecturer attending to what Kohl and Finkelstein (2008) call ‘metalevel’ skill sets or ‘metarepresentational competence’, that is discussing the purpose of representations and ‘knowing what different representations are useful for’ (p. 010108-11).

Moreover, here, the lecturer stresses the fundamental requirements of drawing the FBD and using Newton’s 2<sup>nd</sup> Law to describe the actual physical situation. He asks, ‘Did you use Newton’s 2<sup>nd</sup> Law to figure out what the relative sizes of the vector arrows on the system must be?’ This emphasis is evident in both Table 8.2 (between parts 3 and 8) and in the semantic profile in Figure 8.2, as the lecturer reminds the students to go down from the physical representation (the FBD) back to modelling and to re-reading the concrete, verbal representation, before going up again to modelling and then to the physical representation. In other words, the lecturer shows

the students how to make sense of the FBD and the relevant information contained in the diagram, by showing them how to move up and down the continuum (from concrete to abstract constructs and vice versa), so as to understand their own diagrams. This use of the FBD as a visual representation to help students move from the concrete physical situation to abstract mathematical equations is emphasized in research on the use of FBDs (for example, Rosengrant et al., 2009).

This stage of constructing a FBD occurs much more rapidly in the Mainstream course: here, the lecturer takes about 6.5 minutes (from  $t=0$  minute to  $t=6.5$  minutes on the semantic profile) to move from introducing the problem situation to a completed FBD, whereas in the Extended course, this same process takes about 31 minutes (from  $t=0$  minute to  $t=31$  minutes).

#### 8.3.3.4 *Mathematical representation stage (use mathematical form of Newton's 2<sup>nd</sup> Law and solve)*

As shown by the data, both the Mainstream and the Extended lecturers used FBDs when representing the problem situation mathematically. However, as can be seen in the semantic profiles, the move from the FBD (physical representation) to the mathematical representation of Newton's 2<sup>nd</sup> Law is much quicker in the Mainstream than in the Extended course. The Mainstream lecturer moves directly from the FBD to representing Newton's 2<sup>nd</sup> Law in numerical values. The Extended lecturer first links the sizes of the forces in the FBD to the acceleration, and then asks *'How do I calculate this acceleration?'* The students answer *'By Newton's 2<sup>nd</sup> Law'*. In response, the lecturer refers back to the volunteer group's FBD and tells the students to work in pairs and *'explain why the sizes of the forces are equal or different'* in the  $x$ - and  $y$ -directions and to *'look at the acceleration and the net force'*. He further uses students' responses to write Newton's 2<sup>nd</sup> Law in mathematical form for the  $x$ - and  $y$ -directions. Here, the lecturer helps students correctly to appreciate the significance of understanding Newton's Laws; as he notes, for this representation, students have to *'explicitly use the law to explain why the forces are equal or different'*, and also, *'to communicate explicitly the piece of critical information that will tell us the reason why the arrows are not equal in the  $x$  direction'*.

In the Mainstream course, the lecturer tells the students which law they should apply (in part 4) (unlike in the Extended course, where the lecturer asks them which law they should apply). Here, the Extended lecturer moreover shows the students how he applies the law by using the information he obtains from the FBD in order to solve the problem and answer the question.

The Extended course problem analysed here was a problem task that did not involve numerical values or calculations. The focus of this aspect of the task (before it built on to an understanding of Newton's 3<sup>rd</sup> Law) was to construct a mathematical representation of this particular problem task using Newton's 2<sup>nd</sup> Law. An indication of the acceleration was given (to assume that the crate accelerates to the right), but this was in order to allow students to evaluate the motion of the crate in specific terms and to ascertain the relative sizes and directions of the applied forces. (Problems in which values were inserted into the mathematical representation of Newton's 2<sup>nd</sup> Law were also done in class – see physics task in Chapter 9).

#### 8.3.3.5 Assessment stage

After the mathematical representation, as shown in the external LoD, one needs to assess how sensible the results are and to interpret the quantitative solution in the context of the problem. In the Mainstream course, there is no mention made of evaluating the solution. Although the Extended course problem does not have numerical values, the lecturer tells the students to evaluate the mathematical representation of Newton's 2<sup>nd</sup> Law in terms of the forces represented in the FBD. He points out that students should, as he says, *'explicitly link the acceleration via Newton's 2<sup>nd</sup> Law to the conclusion of how the forces must be and what their relative sizes must be and their directions'*.

## 8.4 Conclusion to Chapter 8

This chapter has presented an analysis of the third lecture sequences in terms of the pedagogical practices observed. This chapter has analysed how problems relating to Newton's 2<sup>nd</sup> Law are dealt with by two lecturers, one in the Extended course, the



other in the Mainstream course. The two main differences relate to the *use of representations* and the *communicative approaches* employed.

Looking first at the use of representations, the semantic profiles show that, in the Extended course lecture sequence, there was more *explicit use of, and shifting between, multiple representations* than in the Mainstream course lecture sequence. These differences in pedagogical practices are similar to the differences noted in the study by Rosengrant et al. (2009), which were also located in two courses – a traditional course, and one in which an explicit, multiple representation approach was used. They noted that the ‘traditional’ instructor did not explain the use of FBDs nor emphasize how students could convert from one type of representation to another in the way that the other instructor did.

Although both courses in my study use the same textbook, which adopts an explicit multiple representations approach, this appears to be more taken for granted in the Mainstream course.

In the Extended course, however, there is a more explicit focus on the techniques of constructing the qualitative representations (the pictorial and physical representations, such as FBDs) needed for successful quantitative problem-solving. There is also evidence here of the lecturer attending to what Kohl and Finkelstein (2008) call ‘metalevel’ skill sets or ‘metarepresentational competence’, in other words, discussing the purpose of representations and ‘knowing what different representations are useful for’ (p. 010108-11). In the Extended course lecture sequence, there is more time for students to practice working with representations themselves, which Van Heuvelen (1991a) notes is often absent in traditional teaching.

Viewing the use of representations from the perspective of Semantics, the Mainstream lecture sequence shows a more rapid shift up the semantic continuum than the Extended lecture sequence, in other words, weakening SG (through a rapid shift away from the concrete problem situation) and strengthening SD (with the meaning of the problem context rapidly being condensed into mathematical representation).

The other notable difference in pedagogical practices relates to the *communicative approaches* used in the lectures. In the Mainstream lecture, the dominant mode was *non-interactive-authoritative* (in other words, a lecture-style exposition), with some *interactive-authoritative parts* (usually in question-and-answer format). Conversely, the Extended lecture was mostly in an *interactive-dialogic* mode (probing, posing questions, and building on students' ideas).

The chapter that follows will investigate how these pedagogical practices influence students' work, in other words, the ways in which students approach physics tasks might be influenced by how they interpret what has been done in class. The discussion above suggests that there may be pedagogical implications, which relate to how students tackle physics tasks. Thus, Chapter 9 will present the findings from the Mainstream and the Extended students when both were observed tackling certain physics tasks related to Newton's 2<sup>nd</sup> Law.



## **Chapter 9:**

### **How the Pedagogy Influences Students' Work**

#### **9.1 Introduction**

Chapter 8 addressed Research Question 1: *What is the nature of the Mainstream and Extended pedagogical practices, in terms of semantic profile? (i.e. semantic gravity and semantic density)?* Chapter 8 did so by focusing on a particular aspect of pedagogical practice, viz. how the lecturers in the Mainstream and the Extended courses dealt with physics tasks involving Newton's 2<sup>nd</sup> Law. Chapter 8 demonstrated that the semantic profiles for dealing with a physics task were different in the two courses.

In this chapter, the focus turns to the ways in which students deal with physics tasks. This will build towards addressing Research Question 2: *What is the correspondence between the pedagogical practices and the ways in which the students approach physics tasks in the Mainstream and the Extended Physics courses?* This chapter analyses how students tackle physics tasks, whereas Chapter 10 will examine whether there is a correspondence between pedagogical practices and students' ways of tackling certain problem tasks.

#### **9.2 Analyses of students tackling Newton's 2<sup>nd</sup> Law physics tasks in the Mainstream and the Extended courses**

This chapter presents an analysis, in the form of semantic profiles, of students tackling physics tasks. Since the analytical process of constructing the semantic profiles is the same as in Chapter 8, detailed data tables are not included in the chapter. An example data table (for Mainstream Group 1) is presented in Appendix 4, to illustrate the data reduction process used in the analysis.

Two student groups from each course were observed tackling a problem task relating to Newton's 2<sup>nd</sup> Law; both tasks involved applying Newton's 2<sup>nd</sup> Law to objects connected by ropes (see the Mainstream and the Extended courses' physics tasks in this section below). The Mainstream course task is slightly more decontextualised

than that of the Extended course (with blocks and ropes vs. a crate, a counter-weight and a rope-pulley system). The structure of the questions is basically the same: Question (a) in both tasks requires the student to draw FBDs; next, Extended course Question (b) requires students to solve for unknown quantities, by applying Newton's 2<sup>nd</sup> Law (this is the same requirement as Mainstream course Questions (b) and (c) together). Despite these similarities, there are also significant differences:

- firstly, modelling assumptions are explicitly stated in the Extended course task ('assume the pulley is massless and frictionless') but not in the Mainstream task;
- secondly, the Extended course task requires more interpretation of the physical situation ('before the crate starts slipping and sliding'), in order to tackle the task (both co-efficients of static and kinetic friction are given and the students have to analyse the task to determine which co-efficient to use);
- thirdly, the task design shows a different emphasis on the use of representations: for example, the Extended course Question (a) requires the students to be specific and precise when drawing the FBD.

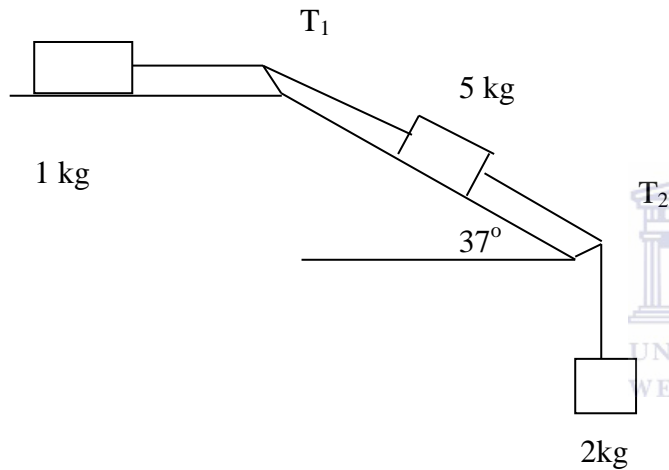
The tasks were taken from class tests, which the students had written a few months earlier. Since I was interested in the students' use of representations when tackling tasks, rather than just in whether they could reach the correct answer, I permitted them to refer to their test scripts, if they felt they were stuck when tackling the task. Students worked on newsprint, and they were interviewed afterwards, in a form of stimulated recall.

### Mainstream course physics task

The question below was in your last semester test (test 4).

#### Question 2

Three blocks are connected by light ropes, as shown in the sketch. The coefficient of friction for all the surfaces is 0,25.



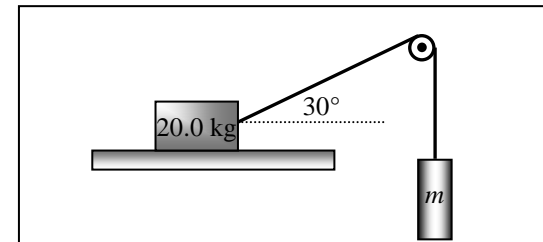
- Draw a free body diagram for each of the three blocks. Label all the forces and indicate the direction of motion for each mass. (3)
- Use Newton's 2<sup>nd</sup> Law to set up the equations of motion for the three masses and simplify. (5)
- Find the acceleration of the system and the tensions  $T_1$  and  $T_2$  in the connecting string. (2)

### Extended course physics task

The question below was in your weekly evaluation test (test 21).

#### Question 2

2. A 20.0 kg crate is connected to a rope-pulley system so that the angle between the rope and the horizontal is  $30^\circ$  as shown in the diagram. The coefficient of static friction between the block and the surface is 0.40 and the coefficient of kinetic friction is 0.15. Assume that the pulley is massless and frictionless.



- Assuming that the system is *at rest*, draw a free body diagram for the crate. Identify all significant forces acting on the crate, show your coordinate axes clearly, and resolve forces into components if required. Also indicate explicitly on your diagram the acceleration of your system and the net force. (3)
- What is the *maximum* counter-weight,  $m$ , that can be attached to the other side of the rope, before the 20.0 kg crate starts slipping and sliding across the horizontal floor? Please note you must apply Newton's 2<sup>nd</sup> law first to the crate, then to the counter-weight,  $m$ , to solve this problem. (4)

### 9.3 The Mainstream course students (Group 1) tackling a physics task

Two groups of students agreed to be video recorded, while working on the physics task. The task had three subdivisions (see below, for the Mainstream course physics task and the memorandum from the lecturer). Group 1 was a group of four students (two females and two males), whereas Group 2 was a group of three male students. Figures 9.1 and 9.2 provide semantic profiles to show the shifts between representations while the two student groups tackled the task by applying Newton's 2<sup>nd</sup> Law. It is apparent that the forms of both semantic profiles in each group are similar.

(Appendix 4 gives an in-depth description of the use of representations by Mainstream Group 1, while tackling the physics task).

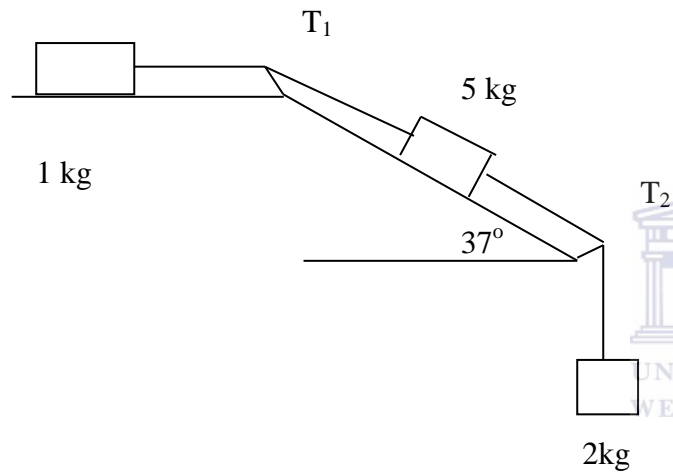


## Mainstream course physics task

The question below was in your last semester test (test 4).

### Question 2

Three blocks are connected by light ropes, as shown in the sketch. The coefficient of friction for all the surfaces is 0,25.



- Draw a free body diagram for each of the three blocks. Label all the forces and indicate the direction of motion for each mass. (3)
- Use Newton's 2<sup>nd</sup> Law to set up the equations of motion for the three masses and simplify. (5)
- Find the acceleration of the system and the tensions  $T_1$  and  $T_2$  in the connecting string. (2)

2a

2b

$$\begin{aligned} \parallel: T_1 - f_k' &= 1 \cdot a \\ \perp: F_N' - 10 &= 0 \\ \Rightarrow F_N' &= 10 \\ f_k' = \mu_k F_N' &= 0,25 \cdot 10 = 2,5 \text{ N} \\ \Rightarrow T_1 - 2,5 &= a \quad \text{--- (1)} \end{aligned}$$

$$\begin{aligned} \parallel: T_2 + 50 \sin 37^\circ - T_1 - f_k &= 5a \\ \perp: F_N - 50 \cos 37^\circ &= 0 \Rightarrow F_N = 40 \text{ N} \\ f_k = \mu_k F_N &= 0,25 \cdot 40 = 10 \text{ N} \\ \Rightarrow T_2 + 30 - T_1 - 10 &= 5a \\ \text{or } T_2 - T_1 + 20 &= 5a \quad \text{--- (2)} \end{aligned}$$

$$\parallel: 20 - T_2 = 2a \quad \text{--- (3)}$$

2c

$$\begin{aligned} \text{(1) + (2) + (3)} \\ T_1 - 2,5 &= a \\ T_2 - T_1 + 20 &= 5a \\ -T_2 &= 2a \\ \hline 3,75 &= 8a \\ a &= 4,69 \text{ m s}^{-2} \\ \Rightarrow T_1 &= a + 2,5 = 7,19 \text{ N} \\ T_2 &= -2a + 20 = 10,63 \text{ N} \end{aligned}$$

## Mainstream course lecturer's memorandum

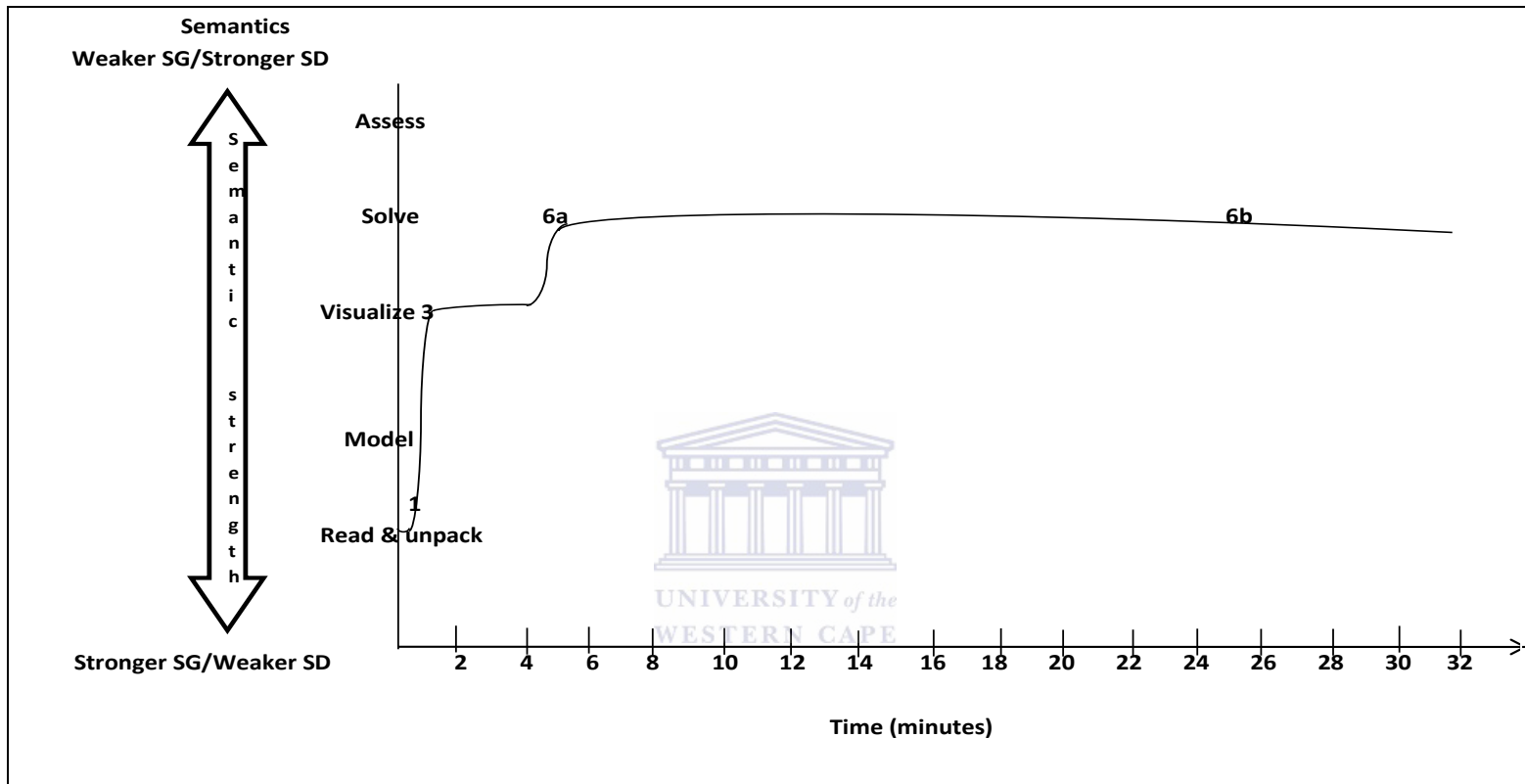


Figure 9.1: The semantic profile for Mainstream Group 1 tackling a Newton's 2<sup>nd</sup> Law physics task



### 9.3.1 Overview of Mainstream course Group 1 tackling a Newton's 2<sup>nd</sup> Law physics task

- In part 1, from 0 minute to 0.5 minutes (*for 0.5 minutes*): **Verbal – Read & unpack**: the students read the statement in order to draw the FBDs.
- In part 2 (*for 0 minutes*): **Modelling**: the students skip over the modelling stage.
- In part 3, from 0.5 minutes to 5.5 minutes (*for 5 minutes*): **Physical – Visualise**: the students draw sketches of the three blocks and the forces acting on the blocks, and indicate the direction of motion for each block.
- In part 4 (*for 0 minutes*): **Modelling**: the students skip over the modelling stage.
- In part 5 (*for 0 minutes*): **Physical – Visualise**: the students skip over this visualization stage, and the group does not use the information from the FBDs to identify Newton's 2<sup>nd</sup> Law for the three blocks.
- In part 6a, from 5.5 minutes to 26 minutes (*for 21.5 minutes*): **Mathematics – Solve: identify & use NII**: the students identify and use the law, but since they did not make sense of the physical situation in parts 1 and 2, they are now confused about whether the blocks are accelerating ( $\sum \vec{F} = m\vec{a}$ ) or not ( $\sum \vec{F} = 0$ ). They are also confused as to whether the mathematical representation  $\sum \vec{F} = 0$  refers to Newton's 1<sup>st</sup> or 2<sup>nd</sup> Law. One student consults her test script, realises that the block *is* in fact accelerating, and so rectifies their mathematical representation accordingly ( $\sum \vec{F} = m\vec{a}$ ).
- In part 6b, from 26 minutes to 31 minutes (*for 5 minutes*): **Mathematics – Solve: use simultaneous equation**: the students identify and use the appropriate equations to calculate the acceleration  $a$ ,  $T_1$  and  $T_2$ .
- In part 7 (*for 0 minutes*): **Assess**: the students do not assess the problem.

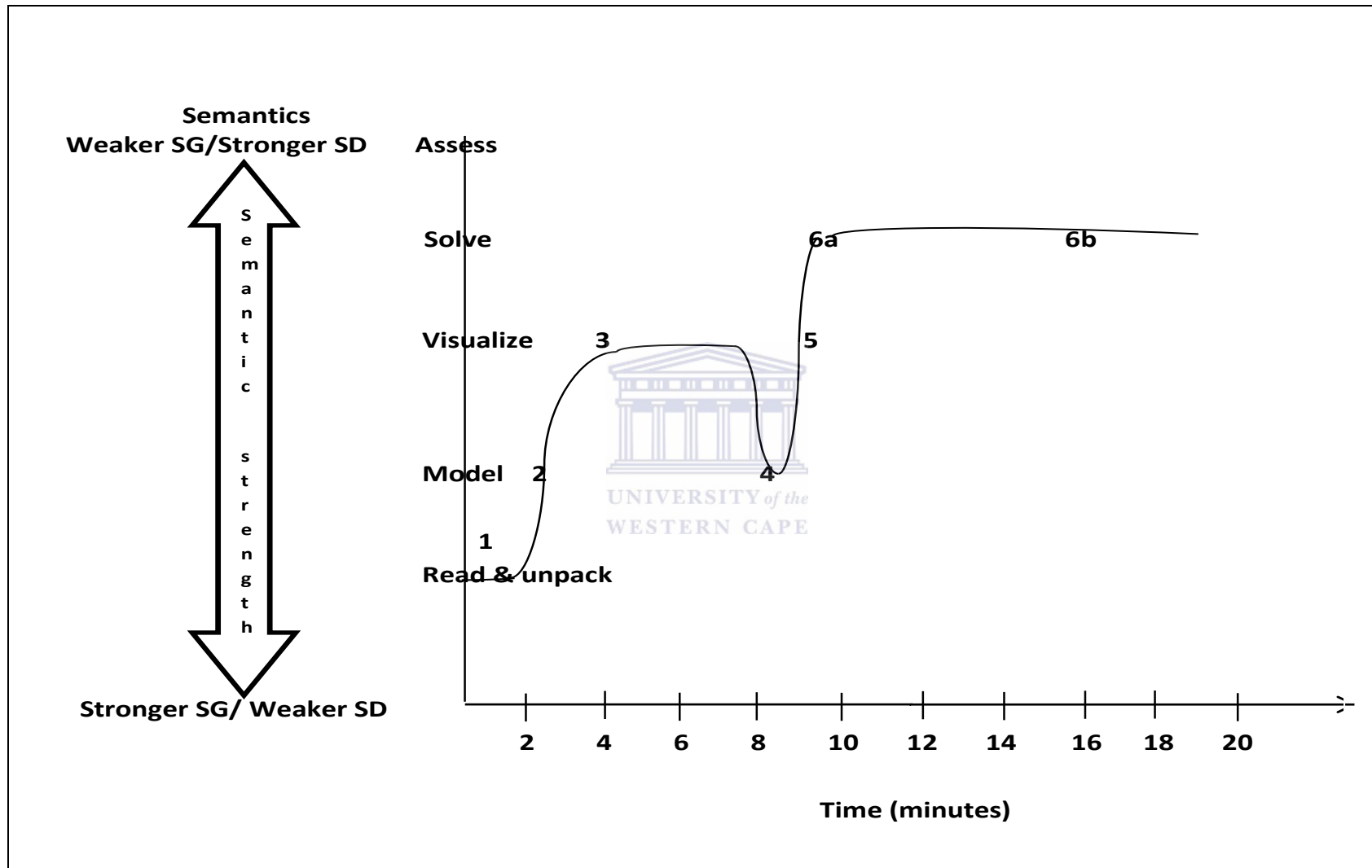


Figure 9.2: The semantic profile for Mainstream Group 2 tackling a Newton's 2<sup>nd</sup> Law physics task

### 9.3.2 Overview of Mainstream course Group 2 tackling a Newton's 2<sup>nd</sup> Law physics task

- In part 1, from 0 minute to 2 minutes (*for 2 minutes*): **Verbal**: the students read the problem statement and sketch the situation of the three blocks. However, they do not identify each block as a system nor do they draw a circle around each block; they also do not identify the external objects or forces interacting with each system.
- In part 2, from 2 minute to 4 minutes (*for 2 minutes*): **Modelling**: the first student (scribe) models the 1kg block as a point particle, but the second student feels that the modelling process will confuse them and thus takes over, drawing a sketch of a 5kg and a 2kg block. This group realises that the 1kg, 5kg and 2kg blocks are connected together with a light rope.
- In part 3, from 4 minutes to 7.5 minutes (*for 3.5 minutes*): **Physical**: the first student draws a coordinate system to specify the signs for the  $x$  and  $y$  axes next to the force diagram. The second student takes over, drawing sketches of the other two blocks and the forces acting on the blocks, but does not indicate the direction of motion for these blocks.
- In part 4, from 7.5 minutes to 8.5 minutes (*for 1 minute*): **Modelling**: the students realise that the system is accelerating in the  $x$  axis (side of the motion), but not in the  $y$  axis. As indicated above, they also realise that all the blocks are connected together with a light rope. Therefore this group makes some assumptions in simplifying the problem.
- In part 5, from 8.5 minutes to 9.5 minutes (*for 1 minute*): **Physical**: the students use the information from the FBDs to identify Newton's 2<sup>nd</sup> Law for the three blocks.
- In part 6a, from 9.5 minutes to 16 minutes (*for 6.5 minutes*): **Mathematics – identify & use NII**: the students identify and use the Newton's 2<sup>nd</sup> Law for the three blocks, but they can only complete some parts of the task as expected, since they had omitted a component of a vector in their FBD.
- In part 6b, from 16 minutes to 19 minutes (*for 3 minutes*): **Mathematics – solve**: the students could use the simultaneous equation to calculate the acceleration; since they had omitted a component of a vector in their FBD, this solution for the acceleration was not correct. They encountered difficulties with the simultaneous equations and did not find the unknown tensions  $T_1$  and  $T_2$ .
- In part 7, (*for 0 minutes*): **Assess**: the students do not assess the problem.

#### **9.4 The Extended course students tackling a physics task**

Two groups of students were video recorded while working on the physics task. As noted above, their task is not identical to the Mainstream course task, but both tasks entailed objects attached to ropes, and required the understanding and application of Newton's 2<sup>nd</sup> Law. The task had two subdivisions (see below the Extended course physics task and the memorandum from the lecturer). Group 1 was a group of three students (one female and two males) and Group 2 was a group of four female students. Figures 9.3 and 9.4 provide semantic profiles to show the shifts between representations while the two student groups tackled the Newton's 2<sup>nd</sup> Law task. It is apparent that the form of both semantic profiles in each group are similar.

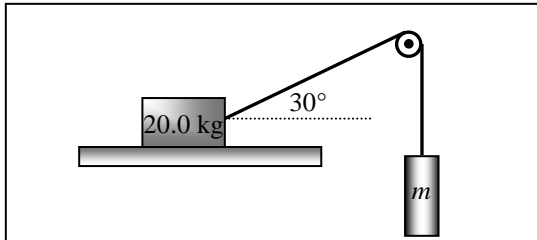


## Extended course physics task

The question below was in your weekly evaluation test (test 21).

### Question 2

2. A 20.0 kg crate is connected to a rope-pulley system so that the angle between the rope and the horizontal is  $30^\circ$  as shown in the diagram. The coefficient of static friction between the block and the surface is 0.40 and the coefficient of kinetic friction is 0.15. Assume that the pulley is massless and frictionless.



2a. Assuming that the system is *at rest*, draw a free body diagram for the crate. Identify all significant forces acting on the crate, show your coordinate axes clearly, and resolve forces into components if required. Also indicate explicitly on your diagram the acceleration of your system and the net force.

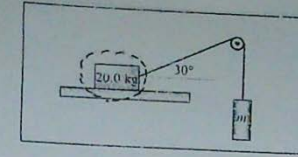
(3)

2b. What is the *maximum* counter-weight,  $m$ , that can be attached to the other side of the rope, before the 20.0 kg crate starts slipping and sliding across the horizontal floor? Please note you must apply Newton's 2<sup>nd</sup> law first to the crate, then to the counter-weight,  $m$ , to solve this problem.

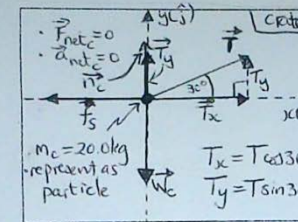
(4)

## Extended course lecturer's memorandum

2a



agents: rope (crate system)  
 normal force  $n_c$  (surface Earth)  
 forces:  $F_{rc} \rightarrow T$   
 $f_s$  (static friction)  
 $W(F_{gc})$  - weight



2b Apply NII to fbd for crate:  $\vec{a}_{yc} = 0$  (crate does not lift off surface)  
 $\vec{a}_{xc} = 0$  (crate on verge of slipping)  
 $f_s = f_{s,max}$  (crate just about to slip)  
 $f_{s,max} = \mu_s n_c$

$$(NII)_y \Rightarrow \sum \vec{F}_y = m_c \vec{a}_{yc}$$

$$n_c \hat{j} + T_y \hat{j} + W_c (-\hat{j}) = 0$$

$$n_c + T \sin 30^\circ - 20g = 0 \dots (1)$$

$$(NII)_x \Rightarrow \sum \vec{F}_x = m_c \vec{a}_{xc}$$

$$T_x \hat{i} + f_{s,max} (-\hat{i}) = 0$$

$$T \cos 30^\circ - \mu_s n_c = 0 \dots (2)$$

$$(1) \Rightarrow n_c = 20g - T \sin 30^\circ$$

Subs.  $n_c$  into (2)  $\Rightarrow T \cos 30^\circ + \mu_s (20g - T \sin 30^\circ) = 0$

$$T (\cos 30^\circ + \mu_s \sin 30^\circ) = 20g$$

$$(\mu_s = 0.40, g = 9.8 \text{ ms}^{-2}) \Rightarrow T = 183.86 \text{ N}$$

find for m

$$(NII)_y \Rightarrow \sum \vec{F}_y = m \vec{a}_{ym}$$

$$\vec{W}_m + \vec{T} = 0$$

$$\vec{F}_{net} = 0 \Rightarrow \vec{a}_{ym} = 0$$

$$\therefore mg(-\hat{j}) + T\hat{j} = 0$$

$$\Rightarrow T = mg \dots (3)$$

$$\Rightarrow m = \frac{T}{g}$$

$$= \frac{183.86}{9.8}$$

$$= 18.76 \text{ kg}$$

$\Rightarrow$  The counter-weight can have a maximum mass of 19 kg before the 20.0 kg crate starts slipping. // 2 sig fig.

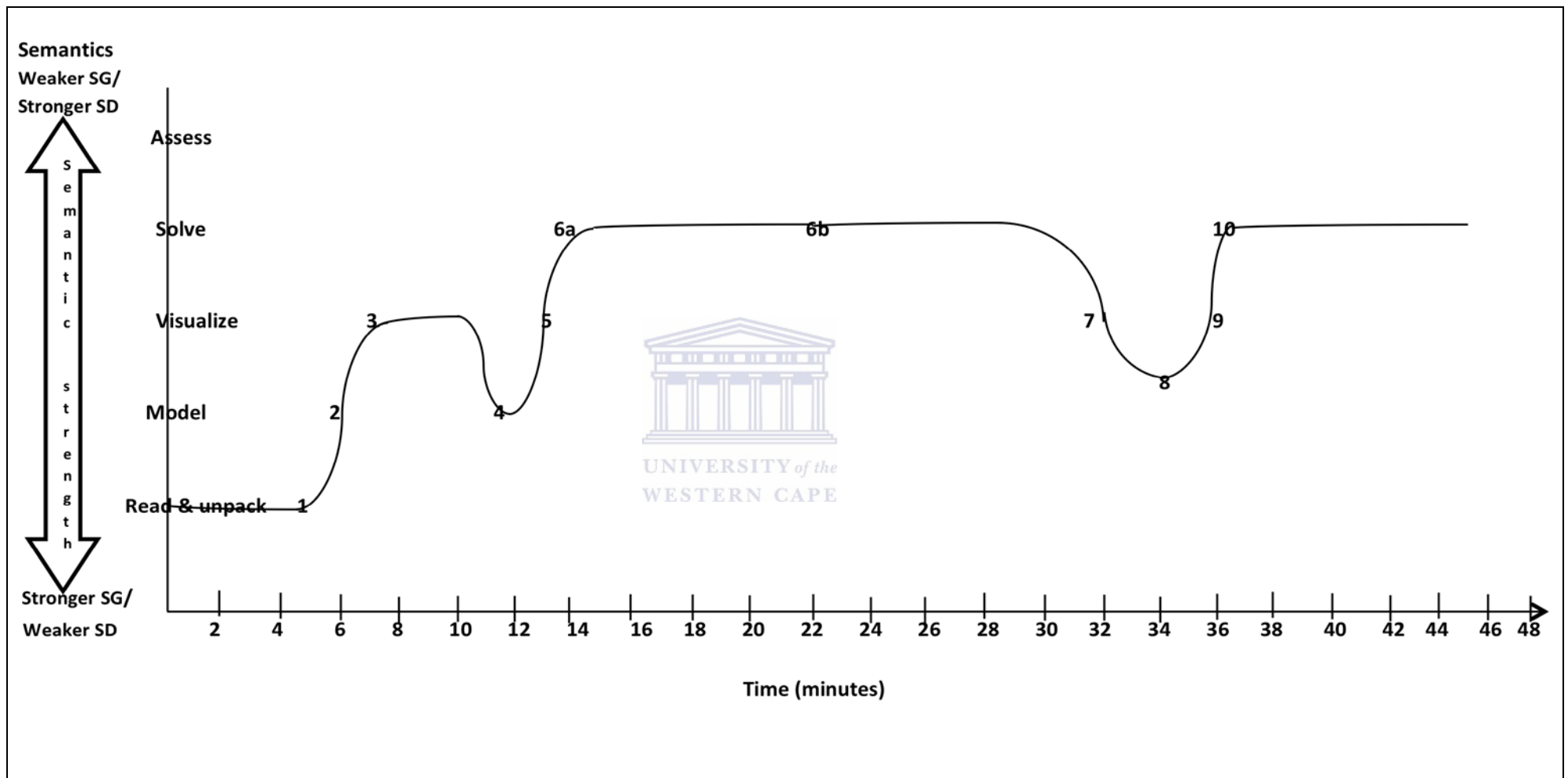


Figure 9.3: The semantic profile for Extended Group 1 tackling a Newton's 2<sup>nd</sup> Law physics task

#### 9.4.1 Overview of Extended course Group 1 tackling a Newton's 2<sup>nd</sup> Law physics task

- In part 1, from 0 minutes to 5 minutes (*for 5 minutes*): **Verbal – Read & unpack**: the students read the problem, redraw the sketch for the crate and then identify the system and the forces interacting on the system (the agents).
- In part 2, from 5 minutes to 6 minutes (*for 1 minute*): **Modelling**: the students make assumptions before they draw a FBD.
- In part 3, from 6 minutes to 11 minutes (*for 5 minutes*): **Physical – Visualise**: the students draw a FBD for the crate, including a co-ordinate system, a dot and the estimated sizes for the force vectors and indicating the acceleration and the net force.
- In part 4, from 11 minutes to 12 minutes (*for 1 minute*): **Modelling**: the students make certain assumptions to simplify the problem: for instance, they realise that the system is not accelerating, and that the acceleration for the crate is equal to zero ( $\vec{a} = 0$ ) and therefore the resultant force is also zero ( $\vec{F}_{\text{net}} = 0$ ).
- In part 5, from 12 minutes to 13 minutes (*for 1 minute*): **Physical – Visualise**: the students use the FBD to identify Newton's 2<sup>nd</sup> Law (in the  $x$  axis  $\sum F_x = ma_x$  and in the  $y$  axis  $\sum F_y = ma_y$ ).
- In part 6a, from 13 minutes to 22 minutes (*for 9 minutes*): **Mathematics – Solve: identify & use NII**: the students successfully set up mathematical representations of Newton's 2<sup>nd</sup> Law for the forces acting on the crate in the  $x$  and  $y$  axis: i.e.  $\sum F_x = ma_x$  &  $\sum F_y = ma_y$ .
- In part 6b, from 22 minutes to 32 minutes (*for 10 minutes*): **Mathematics – Solve: use simultaneous equations**: the students make an error in substituting a value for the co-efficient of friction and get the incorrect value for  $T$ .
- In part 7, from 32 minutes to 34 minutes (*for 2 minutes*): **Physical – Visualise**: the students draw a FBD for mass  $m$ , present a co-ordinate system and a dot, and estimate the force vectors; they correctly draw  $F_g$  the same size as  $T$  to indicate that the net force and the acceleration are equal to zero.
- In part 8, from 34 minutes to 35 minutes (*for 1 minute*): **Modelling**: the students make certain assumptions about the system to simplify the problem and to estimate the sizes for the two forces acting on mass  $m$ , *at rest*.
- In part 9, from 35 minutes to 36 minutes (*for 1 minute*): **Physical – Visualise**: the students use the FBD for mass  $m$  to identify Newton's 2<sup>nd</sup> Law.
- In part 10, from 36 minutes to 46 minutes (*for 10 minutes*): **Mathematics – Solve: identify, use NII & simultaneous equations**: the students use the FBD for mass  $m$  to

identify the Newton's 2<sup>nd</sup> Law:  $\sum F_y = ma_y$ . Since they had not correctly solved for T earlier (in part 6b), they are stuck at this point. They find that they have two unknowns, and go back to their test script for guidance. They struggle to get the final solution and go back to their FBDs to try to pinpoint their difficulties. They run out of time to complete the task.





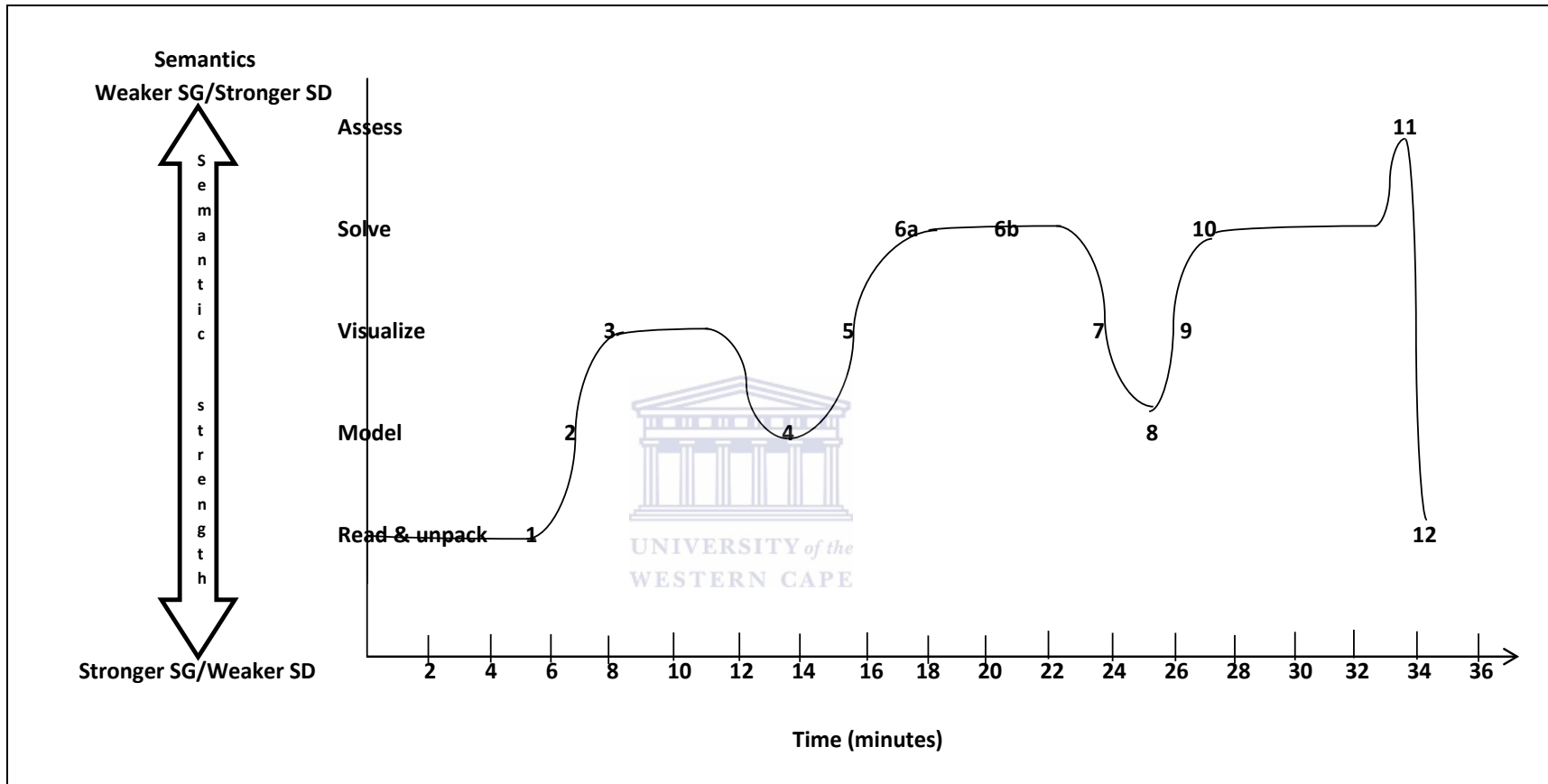


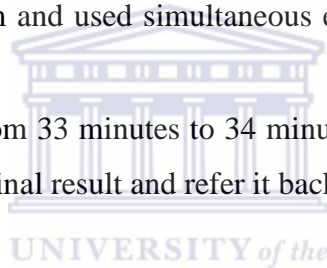
Figure 9.4: The semantic profile for Extended Group 2 tackling a Newton's 2<sup>nd</sup> Law physics task

9.4.2 Overview of Extended course Group 2 tackling a Newton's 2<sup>nd</sup> Law physics task

- In part 1, from 0 minutes to 5.5 minutes (*for 5.5 minutes*): **Verbal – Read & unpack**: the students read the problem, redraw the sketch for the crate and then identify the system and the agents.
- In part 2, from 5.5 minutes to 6.5 minutes (*for 1 minute*): **Modelling**: the students make certain assumptions before they draw a FBD.
- In part 3, from 6.5 minutes to 12.5 minutes (*for 6 minutes*): **Physical – Visualise**: the students draw a FBD for the crate, including a co-ordinate system and a dot; they estimate sizes for the force vectors and indicate the acceleration and the net force.
- In part 4, from 12.5 minutes to 13.5 minutes (*for 1 minute*): **Modelling**: the students make certain assumptions to simplify the problem: they realise that the system is not accelerating, that the acceleration for the crate is equal to zero ( $\vec{a} = 0$ ), and therefore the resultant force is also zero ( $\vec{F}_{\text{net}} = 0$ ).
- In part 5, from 13.5 minutes to 15.5 minutes (*for 2 minutes*): **Physical – Visualise**: the students use the FBD to identify Newton's 2<sup>nd</sup> Law (in the  $x$  axis  $\sum F_x = ma_x$  and in the  $y$  axis  $\sum F_y = ma_y$ ).
- In part 6a, from 15.30 minutes to 17.30 minutes (*for 2 minutes*): **Mathematics – Solve: identify & use NII**: the students successfully set up the mathematical representations of Newton's 2<sup>nd</sup> law in the  $x$  and  $y$  axes. Then, one student becomes confused about whether the crate is in fact accelerating or not. They focus on the wording in the question – 'slipping and sliding' – and then change their minds that it is at rest, and instead use the coefficient of kinetic friction (0.15) to show that the crate is now accelerating.
- In part 6b, from 17.30 minutes to 21 minutes (*for 3.30 minutes*): **Mathematics – Solve: use simultaneous equation**: the students struggle to solve the simultaneous equations. Because of their confusion in part 6a, with an extra unknown value, they are unable to solve the simultaneous equation. After some guesswork, they arrive at an incorrect solution.
- In part 7, from 21 minutes to 24 minutes (*for 3 minutes*): **Physical – Visualise**: the students draw a FBD for mass  $m$ , with a co-ordinate system and a point

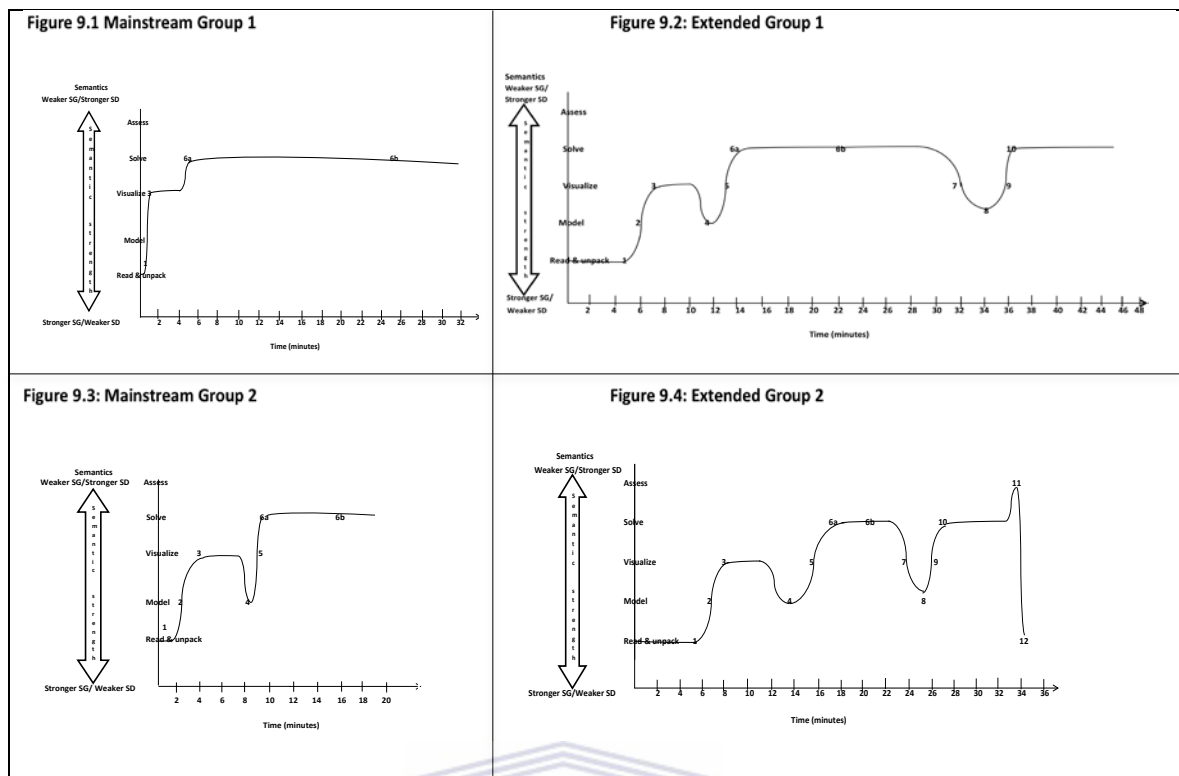
particle; they estimate the relative sizes for the force vectors, drawing  $F_g$  longer than  $T$  to indicate the net force and the acceleration in the problem situation, as they have (mis)interpreted it. The FBD is consistent with their interpretation (viz. that the crate is accelerating), but not correct according to the memorandum.

- In part 8, from 24 minutes to 25 minutes (*for 1 minute*): **Modelling**: the students make certain assumptions about the system to simplify the problem, and estimate the sizes for the two forces acting on mass  $m$ .
- In part 9, from 25 minutes to 26.30 minutes (*for 1.30 minutes*): **Physical – Visualise**: the students use the FBD for mass  $m$  to identify Newton's 2<sup>nd</sup> law.
- In part 10, from 26.30 minutes to 33 minutes (*for 6.30 minutes*): **Mathematics – Solve: identify, use NII & simultaneous equation**: the students use the FBD for mass  $m$  to identify the Newton's 2<sup>nd</sup> Law:  $\sum F_y = ma_y$ ; they have simplified the problem and used simultaneous equations to find the unknown  $m$ .
- In parts 11 and 12, from 33 minutes to 34 minutes (*for 1 minute*): **Assess**: the students evaluate the final result and refer it back to the problem context.



## **9.5 Summary of analysis of the semantic profiles for the student groups tackling a physics task in the Mainstream and the Extended courses**

This section presents the analysis of my observations with regard to how the Mainstream and the Extended student groups deal with a problem task relating to Newton's 2<sup>nd</sup> Law. As in the previous chapter, the semantic profile is used as an analytical tool to show the shifts between the various representations.



**Figure 9.5: Semantic profiles for the student groups tackling a physics task in the Mainstream and the Extended courses**

As shown in Figure 9.5 above, the semantic profiles of the Mainstream student groups differ from those of the Extended student groups. Both groups of students from the Mainstream course and the Extended course put an emphasis on different aspects when tackling the tasks. The semantic profiles of the Extended student groups indicate that they spend more time at the lower part of the semantic continuum, reading and unpacking the problem statement. Moreover, there is evidence of more shifting between representations in the Extended student groups' semantic profiles. The Extended groups also took longer to complete their tasks; this may be because their task required more initial interpretation and because they spent more time on the verbal and physical representations.

From Figures 9.1 to 9.4 (shown side-by-side in Figure 9.5) it is evident that the Extended student groups spend more time on the verbal representation, as well as on modelling and on the physical representation than do the Mainstream student groups.

In the discussion below, I will elaborate on the similarities and differences at the various stages of dealing with the tasks relating to Newton's 2<sup>nd</sup> Law.

### 9.5.1 *How the problem is introduced and set up (read and unpack)*

The first group of students in the Mainstream course does not read the problem with the objective of unpacking the given situation for modelling or making assumptions. They only read the question in order to discuss how they can translate the problem into visual representations, that is, to draw the requested FBDs. The second Mainstream course group reads the question and sketches the situation of the three blocks. However, neither group identifies each block as a system, nor do they draw a circle around each block to indicate the system, nor do they identify the external objects or forces interacting with each system (i.e. identify the agents). This shows that these two Mainstream groups do not spend much time discussing the problem statement; instead, they move swiftly up the semantic continuum to draw a FBD. It will be shown later in the *mathematical representation stage*, that the fact that they do not make sense of the physical situation initially leads to later confusion about the object's motion.

In contrast, the two groups from the Extended course spend more time discussing the problem context. These students read the problem with the objective of unpacking the given situation prior to modeling or making assumptions for the crate and mass  $m$ . Group 1 from the Extended course, after reading the problem statement, starts by discussing the situation:

*So, here the system is at rest, so the acceleration is zero. So, we are going to use static friction. So we have two separate diagrams for each of these [crate and hanging mass]. The system is at rest, so the net force is zero.*

When I asked Extended Group 2 what the system is in this question, and why they need to identify the system and the agents, their response was:

*The crate is the system and the agents are the normal force (surface), static friction, gravitational force (earth) and the tension of the rope ( $\vec{T}_{(rope)}$ ) .... It is essential for us to identify these [agents] before we start solving the problem.*

This kind of a response shows that these students were aware that, if this task has to be abstracted into symbols or diagrams (i.e. to move from the weaker to the stronger SD), they first have to ‘read and unpack’ the given concrete context of the specific problem by drawing a sketch of the situation and identifying the known and the unknowns of the problem. Therefore, they read the question in order to discuss how they can translate the problem from words into pictorial representations, before moving on to a visual representation, viz. drawing the requested FBDs.

In a similar vein, when I asked Group 1 from the Extended course the same questions, they all responded that, ‘*the crate and mass  $m$  are the systems*’. Moreover, they also elaborated individually on why it is necessary to identify the system, as shown in the following extracts:

*Student 1: ‘It helps you, I think when it comes like to problem solving, I think it helps you to get to act much more quicker and you know what to work with when you are asked a specific question. For instance, there we have two systems; if you already identify that in one system as a whole we have two components (pointing at  $x$  and  $y$  coordinate axis), so when the question is asked, you know how to relate the question to a specific component or, if not, the other one.’*

*Student 2: ‘And it also helps you to identify the forces. On the first system we have the normal force but on the second system we don’t. If we didn’t identify the system, we wouldn’t know what is going on according to the forces. We know that the one has friction but the other one has not.’*

*Student 3: ‘I see it as breaking the problem down into smaller parts so that you can relate it (referring to what student 1 had said) as to get the big picture to each one and then break the problem down to smaller parts and then you can see what relates to what in the whole system.’*

These types of responses demonstrate that these students have an understanding of the specifics of this verbal representation. That is, they understand that, in order to translate the problem from words into visual representations – which is to abstract the concrete situation (the written words) so that they can diagrammatically draw the

requested FBDs – they first have to draw a sketch of the situation, so that they can identify the system from the agents or the external forces exerted on it.

The differences observed between the Mainstream and the Extended groups in this initial stage of tackling the physics task reflect the pedagogical practices described in Chapter 8. In the same way as when the lecturer was working on the Newton's 2<sup>nd</sup> Law problem tasks, in using the lens of SG, it can be observed that the Mainstream students – like the lecturer – have quickly weakened the SG; they tend to move quickly towards abstraction, that is, from the problem context to the physical representation. In contrast, the Extended students – like their lecturer – focused extensively on the concrete level; here, these students identified the agents before abstracting to represent the forces on the FBD.

As seen in the semantic profiles above (Figures 9.1 to 9.4), this verbal representation stage or reading and unpacking the problem statement took significantly longer in the Extended student groups than in the Mainstream student groups (5 minutes in Extended course Group 1 and 5.5 minutes in Extended course Group 2 versus 0.5 minutes in Mainstream course Group 1 and 2 minutes in Mainstream course Group 2).

### 9.5.2 *From the verbal representation to a FBD (model the situation)*

From the semantic profiles, it is evident that the Mainstream student groups spend less time than the Extended student groups in modelling the situation. The Mainstream students do not seem to realize that a point particle implies a modelling process; the first group skipped the modelling stage entirely and went directly to draw the FBDs, instead of representing each of the three objects of interest as a point particle first. In Group 2 of the Mainstream course, the scribe begins to model the first object of interest as a point particle. However, the other students in the group do not see the necessity of doing this, as one of them says, *'this will just confuse us'*. They then continue to draw the sketches of the other two objects of interest as blocks, not as point particles. Later, when I probed them about the meaning of the dot (or a point particle) when drawing a FBD, it seemed that the initial scribe viewed drawing a dot and drawing a block as equivalent, as he said, *'It [dot] is equal or the same as drawing a block'*. When I asked the rest of the group whether they agreed with his

response, the third student said that he personally prefers the sketch instead of drawing a dot. As he said, *'for instance, when drawing the block, you could see exactly what and where the block is, but the dot will be hidden over when indicating the axes'*. The second student felt the same, that, *'the dot will be difficult to see'*. In their responses, there was no indication of the modelling implicit in the point particle representation. This reflects the pedagogical practices noted in Chapter 8, where the Mainstream course pedagogy did not explicitly deal with point particle modelling.

In contrast, the groups of students from the Extended course recognised that, in moving from the verbal representation to draw the requested FBD, the modelling of the object as the point particle has a significant meaning. This is evident in Group 1's response, when I asked them a similar question as I had the Mainstream groups about the meaning of the dot: *'the dot represents the crate, it has mass but we are modelling it as shapeless in 2 dimensions'*; Group 2 said, *'the dot represents the crate and the other one the counter-weight  $m$ '*. These two groups consequently draw a dot in the middle of the coordinate systems to model the crate and mass  $m$  as a point particle in their solutions. Moreover, they are able to use their assumptions to identify whether the object of interest is accelerating and is experiencing a resultant force or not. Therefore these groups make certain assumptions for the objects of interest before they draw a FBD and then move into a mathematical representation of the problem.

Conversely, the two groups from the Mainstream course have not explicitly identified the acceleration and the resultant force for the objects of interest.

### 9.5.3 *Constructing the physical representation – the FBD (visualise)*

As shown in the semantic profiles above (Figures 9.1 to 9.4), the Extended course groups spend a significantly longer time constructing FBDs than do the Mainstream course groups. As noted earlier, the Extended task design required them to be more explicit in using the FBDs. Up to this point, the Mainstream groups had not explicitly discussed and identified the acceleration and the resultant force for the objects of interest; they are thus unable to use this transition stage of drawing the FBD effectively. In other words, they cannot link the information they were given in their written and pictorial representations to the FBD.



There were also several differences in the approach to drawing a FBD in the Mainstream and the Extended course groups. Firstly, both of the Extended groups draw *a co-ordinate system*, with an indication of the direction of the acceleration and the  $F_{\text{net}}$ . The Mainstream Group 1 draws an arrow to indicate the direction of motion of the systems, and specify the positive direction for the forces acting on the systems. The students from Mainstream Group 2 establish a co-ordinate system for only one object of interest. In addition, this group realizes that the objects of interest are connected together with the light rope, but they do not indicate the direction of motion or specify the signs to highlight their understanding or their translation or transition from the information that was given about the other two objects of interests.

The second difference was the depiction of the *force vectors*. The Mainstream groups draw these roughly and fail to emphasise the details of the *relative sizes* of the force vectors; Group 2 does not resolve all the vectors into their  $x$  and  $y$  components (this leads to difficulties in the mathematical representation stage later on); conversely, the Extended Group 1 takes great care to draw the force vectors with the correct relative sizes, and also to resolve the vectors into their  $x$  and  $y$  components on the FBD (see part 3). They note:

*On the diagram (FBD), in the  $y$  axis, the component of tension and the normal force together must be equal in magnitude to the gravity because the system is at rest* (they take care in drawing and measuring the vectors with a ruler, drawing the normal force as 5cm, the  $y$  component of tension as 4cm, and then add these together to draw  $F_g$  as 9cm)

Another difference is that the Mainstream student groups label the force vectors with a single *subscript*, whereas the Extended student groups label the force vectors with a double subscript, indicating the agent acting on the object of interest.

When I interviewed the Mainstream Group 2, I asked them whether they thought they would have drawn a FBD if they had not been instructed to do so. All of them said 'yes', they would draw a FBD; the third student elaborated by saying:

*Even if I'm not told to draw a diagram, I'll generally draw or just sketch*

*something or otherwise it will be difficult for example to approach... like in a test or stuff... to imagine what is going on in the situation. It is easier to draw a sketch and you can look and say these three blocks, the one is in this angle, and instead of keeping all of this in your head and you still have to think of the calculations and stuff to do and do all of this in the paper.*

The second student echoed this by saying, *'and it's easy to make mistakes – we almost forget the kinetic..., what you call this... kinetic friction'*. The third student simply said, *'it just makes things easy'*. While I was listening to their responses, I had a sense that these students know that they should draw a FBD, but they do not know the actual reasons why they are using it as a particular representation. As pointed out by Kohl and Finkelstein (2008) in their study, students often do not know how to use a FBD to maximum effect. Moreover, their responses demonstrate that these students do not seem to understand a clear distinction between the sketch (or pictorial representation) and a diagram (or physical representation) in physics, as one of them states that, *'I'll generally draw or just sketch something'*.

Conversely, when the groups in the Extended course were asked the same question about drawing the FBD, their explanation shows a depth of understanding of the FBD as a specific representation. Group 1 said, *'yes, you have to [draw a FBD]'*, and one student elaborated, *'because it makes it easier to calculate when you have a FBD; it helps you to see which forces are in the x or y direction, especially if you have components'*. Furthermore, Group 1 said, *'the free body diagram also gives you an indication of the relative sizes of the forces so you know that the system is at rest or moving or so'*. In this part of the task, both groups know that even the lengths or sizes of the arrows, which indicate the forces, will also help them in finding the solution in this problem, as they are abstracting the problem from the concrete context. As Group 2 mentioned:

*The length of the arrow tells us the magnitude and the arrow end, just the direction in which the force is exerted; like the frictional force is opposing the motion – that is why it is going to the negative direction.*

Their responses indicate a carefulness in figuring out the relative sizes of the force vectors to correspond with the concrete physical problem situation:

*The sizes of the vectors depend on the sum of the forces in that direction. In this case, we add  $T\sin 30^\circ$  and the normal force together to get the size of the gravitational force. For this case, they need to be equal to counteract one another because we take consideration of the static friction. If it is smaller, the crate will be moving but if it is bigger than the component of the tension, it will be standing still and that means the vertical forces should cancel each other. Static friction means the object is at rest.*

These kinds of responses thus show that these students know the actual reasons for drawing the FBD and using it as a particular representation; they show evidence of a developing of ‘metarepresentational competence’ (Kohl & Finkelstein, 2008).

Moreover, when I asked the Extended course groups about the necessity of choosing the co-ordinate system, they showed a comprehensive understanding of its importance:

*If I want to see components, I wouldn't know which one is the sum of my  $x$  or  $y$ , so I have to choose any of those and that will complicate my calculation and make it difficult for someone else to see what forces are about. But when they see the coordinate system, they will know these forces are going to the  $y$  or  $x$  direction without even having the knowledge of physics. That makes it easier to see something and to do your calculations. It's hard for me to go straight to the calculation without having the coordinate system.*

Group 2 shared the same insight about choosing the co-ordinate system and expanded on this by saying:

*By indicating the axis, it helps you to communicate with the person who's actually going to correct your work; for instance, when you label your axis, you know that if you get the positive value at the end, the motion is going on the positive side and negative, automatically the person will know, it's going towards the negative side. I think its communication, that's it.*

From these comments, it is possible to see that these students are not just using these diagrammatic and symbolic representations only for their own benefit, but they are also concerned about the person who will be reading their script. As a result, when they are writing, they focus on communicating to the reader, and thus ensure that they

have sufficient information in their scripts so that it will be clear to the reader that they are explicitly expressing their level of understanding and their thought processes.

Moreover, when both groups discussed the FBD representation, they realized that the crate and mass  $m$  are not accelerating; Group 1 also explicitly expressed their understanding of the relationship between acceleration, resultant force and friction:

*If there is static friction, the block is not moving.... and therefore there is no acceleration.*

Group 2 expressed a similar understanding:

*In order to do the calculations, you need to know what you are working with; and if we didn't draw the free body diagrams, we will be confused; that is the normal force upwards, the gravity or the tension or what happens to the tension. On the system (pointing to the sketch), the tension is slanted, but on the free body diagram, we divided it into component form so that we know which one falls under the y and which one falls under the x.*

In summary, it seemed that the Extended students had developed a deeper understanding of the role of a FBD as a physical representation than did the Mainstream course groups. Both groups in the Extended course managed to draw the FBDs correctly. Mainstream Group 2 omitted to draw one component on one of their FBDs; Mainstream Group 1 successfully satisfied the conditions of drawing the FBDs for all the given blocks according to the memorandum. However, in both cases, the essence of what is needed when drawing a FBD, and the recognition of the difference between a sketch and a FBD, and the role of a FBD in applying Newton's 2<sup>nd</sup> Law, are not fully appreciated by these students.

#### 9.5.4 *Mathematical representation (set up mathematical form of Newton's 2nd Law and solve)*

The mathematical representation consists of two stages:

1. students need to *set up* the mathematical representation of Newton's 2<sup>nd</sup> Law in the  $x$  and  $y$  axes, and then
2. they need to solve using simultaneous equations.

In the first stage – *setting up* the mathematical representation – it was observed that the Extended student groups did this more easily than the Mainstream student groups did. This is because the Extended course groups have already made sense of the concrete problem situation; as noted in Section 9.5.1 above (*How the problem is introduced and set up*), the students have already discussed whether the crate is accelerating or not, what the net force is, and that the two systems are connected:

*So here, the system is at rest, so the acceleration is zero. So we are going to use static friction. So we have two separate diagrams for each of these [crate and hanging mass]. The system is at rest, so the net force is zero.*

They furthermore explicitly use the FBD to write the correct mathematical form of Newton's 2<sup>nd</sup> Law.

In contrast, the Mainstream groups, as noted in Sections 9.5.2 and 9.5.3 above, neglect to discuss or model the problem situation, and they also draw the FBDs with little reference to the concrete physical situation that they represent. When they embark on the mathematical representation stage, they consequently become confused about whether the blocks are stationary or accelerating. Up to this point, they have not discussed the physical situation of the problem statement, and Group 1 now argue about this. One student suggests:

*When you're doing it with the diagram, you have to look at these things separately.*

The second student disagrees:

*'If the whole system is moving, then each thing is moving!'*

Despite the fact that the problem statement explicitly states that the blocks are 'in motion' and that the system is accelerating, the students decide that there is no net force on the 2<sup>nd</sup> block, and by implication, no acceleration. They write this mathematically as: ' $\sum F = 0$ '

Such confusion at the abstract, mathematical representation stage of the problem arises because the students have not spent enough time reading and making sense of the concrete physical problem situation. They have not established at this early stage the obvious point, viz. that all three blocks (which are attached to each other) would have identical motion, and that they are accelerating and not stationary. They do not model the problem or draw careful FBDs as tools to think about the sizes of the force vectors, which would have helped them to consider the size and direction of the net force and the acceleration in the problem situation. As noted earlier, the FBD is not being used as a tool to guide their mathematical representation.

After this initial confusion, one student consults her test script, realizes that the block *is* in fact accelerating, and so rectifies their mathematical representation ( $\sum F = ma$ ) accordingly. Importantly, there is no linking back to the problem statement at this stage; the test solution is taken as given. The group then successfully solves the problem, although it would appear they do so by behaving rather mechanically or algorithmically (Kohl & Finkelstein, 2008). The group's focus is thus on moving rapidly up the semantic continuum, using abstract mathematical representations with weak SG and strong SD without first having a solid understanding of the concrete problem statement.

In the second stage of the mathematical representation – *solving using simultaneous equations* – both the Mainstream and the Extended course groups had mixed success. Mainstream Group 1 sets up the simultaneous equations correctly, and arrives at the correct solution (although they have used the students' test script as a reference).

Mainstream Group 2 has omitted a component of a vector in their FBD, which leads them into difficulties with the simultaneous equation, but they nonetheless reach a solution (even though this is not correct, due to their error on the FBD).

Extended Group 1 sets up the simultaneous equations correctly, and then, when solving, they make an error in substituting a co-efficient of friction value (they write 40 instead of 0,40). While struggling to get the final solution to this question, they look at their test script for guidance. What is interesting about Extended Group 1 is

that they do not simply look at the solution and move on (as Mainstream Group 1 do), but instead they go back to their FBDs on the newsprint to try to understand the question. It seems that their intention is not to copy the solution but rather to understand where the source of their difficulty is, so that they can work on it and find the solution of the problem on their own. I had to stop them after 20 minutes because time had run out.

Extended Group 2, having set up correct FBDs and correct mathematical representations, encounters disagreement within the group. One student misinterprets Question (b) and assumes that the system is accelerating ('slipping and sliding') rather than at rest ('before slipping and sliding'). The group changes their FBDs and thus sets up incorrect simultaneous equations. They reach a solution (although not correct).

#### *9.5.5 Assessing and evaluating the solution*

As discussed in Chapter 8, in this part of tackling a physics problem, the lecturer in the Mainstream course does not evaluate the solution. The students of this course behave similarly. Neither of the two groups assesses the problem to evaluate the final solution or verify the answer from the questions. They also do not check and refer the final solution back to the context of the problem.

Likewise, Group 2 from the Extended course approaches this part of tackling a physics problem in the same way as their lecturer. These students evaluate the final solution, checking and referring it back to the context of the problem. Group 1, however, was unable to assess the task (since I had to stop them due to reaching the time limit).

## **9.6 Conclusion to Chapter 9**

Chapter 9 has presented the research findings on how the students in the Mainstream and the Extended courses tackled physics tasks. In both courses, the students were observed in small groups, as they tackled the physics tasks; afterwards, they were interviewed about the task they had just completed.

As can be seen in the semantic profiles, the Mainstream groups show a more rapid shift up the semantic continuum than do the Extended groups. The Extended groups spend more time at the concrete level, reading and making sense of the problem statement *before* they move up the semantic continuum, unlike the Mainstream groups, which move more quickly to the mathematical representations. The use of FBDs is also distinctively different in the Mainstream and the Extended groups. In the Mainstream groups, the FBDs were drawn mechanically and were not really put to use in setting up the mathematical representations, despite the function of FBDs being to help in the move from the concrete situation to a mathematical representation (Rosengrant et al., 2009). In contrast, the Extended groups took great care in constructing their FBDs, so that the relative sizes of the force vectors were accurate and consistent with the concrete, physical situation.

In summary, the Extended course students seemed to move more easily up and down between the various qualitative and quantitative representations, displaying what Airey and Linder (2009) refer to as ‘discursive fluency’; they also seemed to have a greater awareness of the purpose of each sort of representation, that is, ‘representational competence’ (Kohl & Finkelstein, 2008). Although both Mainstream student groups are partially successful in completing the task, their focus was on solving the problem mathematically, without initially making sense of the problem context. Moreover, they seemed to view FBDs as merely a mechanical step, rather than as a useful transitional stage between a sketch and a mathematical representation.

It is perhaps not surprising that the ways in which students tackled physics tasks in each of the courses is to a large extent similar to the pedagogical practices described in Chapter 8. Furthermore, the way in which the tasks are designed and assessed also explains the use of the different modes of representations. As noted in Section 9.2, the tasks have different emphases: the percentage of marks allocated for mathematical representation in the Mainstream and the Extended task memoranda is 66% and 50% respectively. Within the marks for the mathematical representation, the Extended task memorandum allocates a mark for *interpreting* the numerical solution in relation to the concrete problem situation, whereas the Mainstream memorandum does not. Marks allocated for FBDs are also different: the Mainstream task required roughly



drawn and labeled force vectors, whereas the Extended task required evidence that students had made sense of the problem situation first, and had drawn the relative sizes of the vectors accurately (as shown in both memoranda). In general, there is more emphasis in the Extended course memorandum on making sense of the problem situation, before proceeding to the mathematical representation.

The correspondence between the pedagogical practices used and the ways in which students approach tasks will be discussed further in the Discussion chapter (Chapter 10). This chapter will bring together the research findings from Chapter 6 to 9, as well as highlight the pedagogical implications of this research.



# Chapter 10:

## Discussion

### 10.1 Introduction

This chapter gathers together the research findings from Chapters 6 to 9 into one cohesive discussion. The chapter is organised into various sections according to the research questions and the themes that emerged from the analysis of the findings, which were presented in Chapters 6 to 9. This chapter will also discuss the implications of this research for the teaching and learning of university physics.

Considering the imperative of widening epistemological access to science studies and to the discipline of physics, the data analysis in Chapters 6 to 8 sought to address the research question concerning the pedagogical practices in the two introductory physics contexts at UWC – the Mainstream and the Extended courses. Thereafter, Chapter 9 presented the data analysis, examining specifically how problem tasks are dealt with by students. Chapter 10 now addresses the correspondence between the pedagogical practices and the ways in which the students approach physics tasks in these two introductory courses.

The research questions of the study are repeated below, and will be discussed in Sections 10.2 and 10.3 below

1. What is the nature of the Mainstream and Extended pedagogical practices in terms of their semantic profiles (i.e. semantic gravity and semantic density)?
2. What is the correspondence between the pedagogical practices and the ways in which students approach physics tasks in the Mainstream and Extended Physics courses?

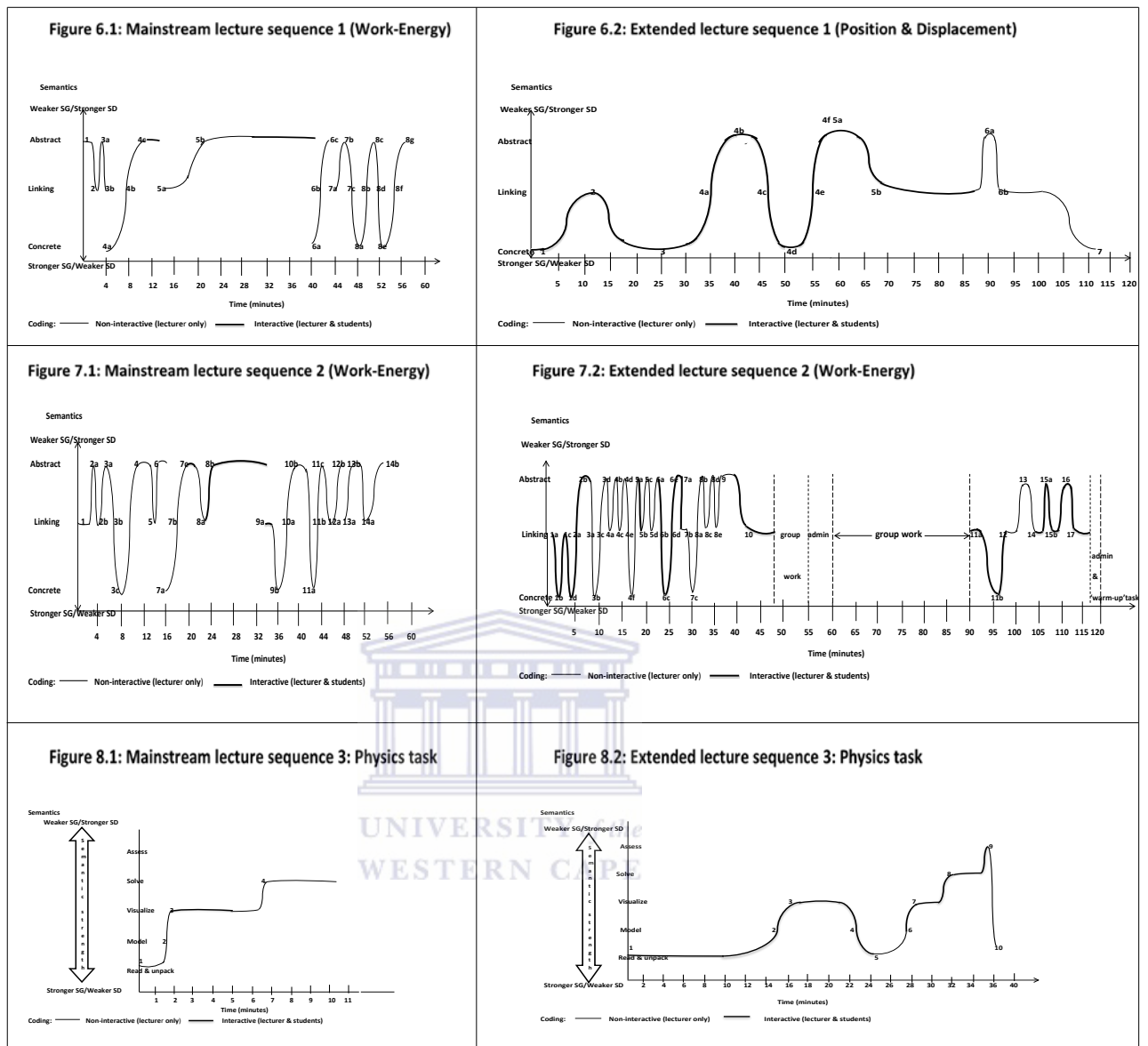
## 10.2 Research question 1: What is the nature of the Mainstream and Extended pedagogical practices in terms of their semantic profiles (i.e. semantic gravity and semantic density)?

A summary of the semantic profiles for the pedagogical practices in the Mainstream and Extended courses is given in Figure 10.1. This brings together the semantic profiles, which were discussed more fully in Chapters 6 to 8. The top two semantic profiles (Figures 6.1 and 6.2) are from the data analysis in Chapter 6, which looked at the pedagogical practices when the lecture sequences occurred at *more-or-less the same time during the academic year*. The middle two semantic profiles (Figures 7.1 and 7.2) are from the data analysis in Chapter 7, which investigated the pedagogical practices in lecture sequences dealing with *similar content knowledge*. Finally, the bottom two semantic profiles (Figures 8.1 and 8.2) are from the data analysis in Chapter 8, which focused on a particular aspect of physics pedagogical practice, that is, *how physics tasks are dealt with in class*.



## Mainstream course

## Extended course



**Figure 10.1: A summary of the semantic profiles for the lecture sequences in the Mainstream and Extended courses, presented in Chapters 6 to 8.**

The analysis of the semantic profiles presented in Chapters 6 to 8 (and summarized in Figure 10.1 above) suggests that the semantic profiles for the Mainstream and Extended courses are quite different. The semantic profiles in Figures 6.1 and 6.2 show that the profile of the Extended course is less compressed than that of the Mainstream course, with more time being spent at the Concrete level in the Extended lecture sequence. This lecture sequence in the Extended course was captured at the

start of the Mechanics section of the curriculum, while the lecture sequence of the Mainstream course was captured later in the Mechanics section.

The second pair of lecture sequences (Figures 7.1 and 7.2) both occurred at the end of the Mechanics section; they are based on *similar content knowledge* and have fairly similar semantic profiles. The Extended course profile is now more compressed than in Figure 6.2 and the first half of the Extended course profile is very similar to the Mainstream course profile in terms of compression. The second half is less compressed, with more time for student engagement. This result also reflects the progression in the Extended course, where the pace is slower initially during the academic year, and later becomes more ‘Mainstream-like’ in terms of pace (as indicated by the level of compression).

Finally, the bottom two semantic profiles (Figures 8.1 and 8.2) reflect *how physics tasks are dealt with in class*. Again, the Extended course profile is less compressed than the Mainstream course profile, and there is more time spent at the Concrete level in the Extended course than in the Mainstream one, with more pedagogical moves between representations in the former.

In addition, as indicated in the semantic profiles (viz. the line thickness), there was more IE (thick line) during the Extended course lecture sequences (Figures 6.2, 7.2 and 8.2) and many instances when students themselves were engaged in making the shifts in SG and SD.

A more detailed discussion of the differences in the semantic profiles for the Mainstream and Extended courses is given in Table 10.1, which should be read in conjunction with Figure 10.1.

**Table 10.1: Key aspects of the semantic profiles of the Extended course in relation to those of the Mainstream course**

| Mainstream course  | Extended course   |
|--|---|
| <i>Entry/exit points</i>   |   |
| - Figure 6.1: starts and ends at the Abstract level<br><br>- Figure 7.1: starts at the Linking level with an immediate shift into a sequence of Linking-Abstract shifts and ends at the Abstract level   | - Figure 6.2: starts and ends at the Concrete level<br><br>- Figure 7.2: starts at the Linking level with a shift into a sequence of Linking-Concrete shifts and ends at the Linking level  |
| <i>Semantic range</i>  |   |
| - Smaller semantic range, mainly between Abstract and Linking levels<br><br>- Figure 6.1 and Figure 7.1: Extensive portion of the lecture is spent at the Linking level, though more time is spent at the Abstract level than at the Concrete level; when the lecture is at the Concrete level, this is only for a short time, before moving back to the Linking level                       | - Larger semantic range, including more shifts to the Concrete level<br><br>- Figure 6.2 and Figure 7.2: Extensive portion of the lecture is spent at the Linking level and more time is spent at the Concrete level than at the Abstract level   |
| <i>Compression and proportion of lecture time spent at the Abstract, Linking and Concrete levels</i>   |   |
| - Figure 6.1 ( <i>same time during the academic year</i> ): semantic profile shows greater compression than the Extended course<br><br>- Figure 7.1 ( <i>similar content knowledge</i> ): proportionally more time is spent in the Abstract level (4 instances within 60 minutes).<br><br>- Figure 8.1: the time spent on dealing with a problem task is much more compressed (10.5 minutes) | - Figure 6.2 ( <i>same time during the academic year</i> ): semantic profile shows less compression than the Mainstream course<br><br>- Figure 7.2 ( <i>similar content knowledge</i> ): the 1 <sup>st</sup> half of the lecture was more compressed with a greater proportion of time spent at the Concrete level (6 instances within 48 minutes) and the 2 <sup>nd</sup> half of the lecture was less compressed<br><br>- Figure 8.2: the time spent on dealing with a problem task is less compressed (36 minutes) |
| <i>Semantic flow (discontinuities)</i>   |   |
| - Figure 6.1: between parts 3b and 4a; 4c and 5a; 5b and 6a<br><br>- Figure 7.1: between parts 6 and 7a; 8b and 9a   | - In all the lecture sequences, there were no discontinuities   |
| <i>Communicative approaches</i>  |   |
| - In all the lecture sequences there was a dominant non-interactive-authoritative approach   | - In all the lecture sequences there was an interactive dialogical ('interactive engagement') approach  |

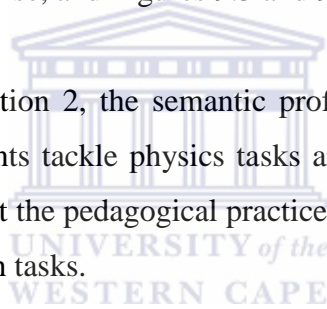
In addressing Research Question 1, the LCT analysis of lecture sequences has revealed several differences in the pedagogical practices of the Mainstream and Extended courses, in terms of entry/exit points, semantic range, compression of

semantic profile, the relative time spent at Concrete, Linking and Abstract levels, discontinuities and communicative approaches.

### **10.3 Research question 2: What is the correspondence between the pedagogical practices and the ways in which the students approach physics tasks in the Mainstream and Extended Physics courses?**

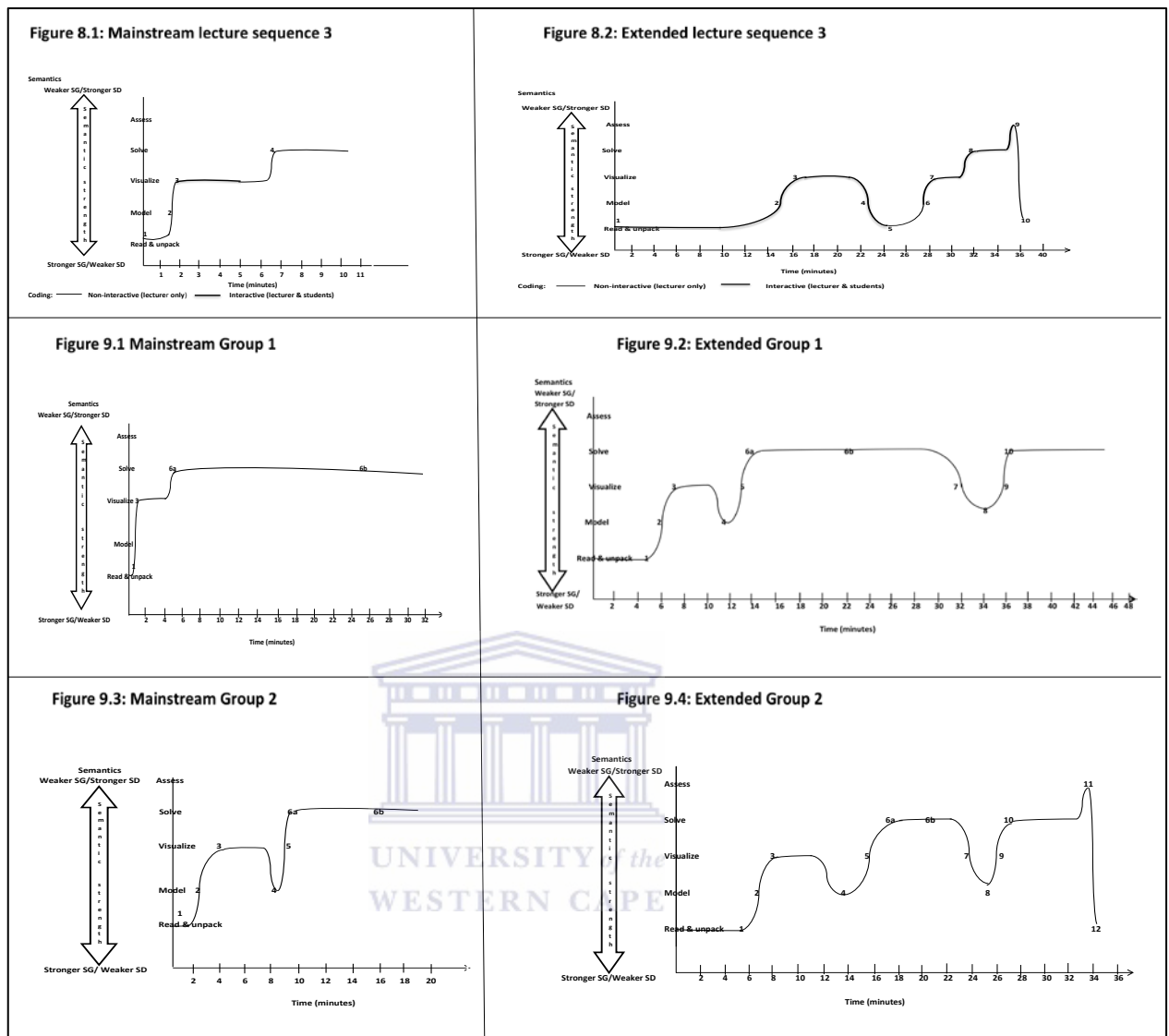
A summary of the semantic profiles relating to how physics tasks are tackled in the lectures and how students tackle such tasks is given in Figure 10.2. This brings together the semantic profiles, which were discussed in Chapters 8 and 9. The top two semantic profiles (Figures 8.1 and 8.2) are for the Mainstream and Extended lecture sequences, respectively. The semantic profiles for the two groups of students tackling physics tasks are presented below the lecture sequence profiles (Figures 9.1 and 9.2 are for Group 1 from each course, and Figures 9.3 and 9.4 are for Group 2).

In addressing Research Question 2, the semantic profiles for pedagogical practices and the ways in which students tackle physics tasks are compared, and it is evident from the semantic profiles that the pedagogical practices are to a large extent reflected in how students approach such tasks.



Mainstream course

Extended course



**Figure 10.2: A summary of the semantic profiles for the Mainstream and Extended lecturers and students while tackling a physics task**

The Mainstream semantic profiles (both with regard to pedagogical practices and students’ work) show a rapid movement up the semantic continuum towards abstract mathematical representations, without much time being spent on reading the problem statement or modelling the problem. The Extended semantic profiles show that much more time is spent initially on reading and unpacking the concrete problem situation, modelling the situation and working with the verbal and physical representations (the FBDs) to help the students make sense of the situation. There is also more frequent shifting up and down the semantic continuum in the Extended lecture sequence, which is also reflected in the students’ semantic profiles.



Table 10.2 below provides a summary of the time spent by the lecturers and by the student groups on each representation while tackling a physics task (Note: the term ‘instances’ is used to indicate that there is sometimes movement ‘back and forth’ between representations; the total time spent in a particular representation can be made up of several instances). From the table, it is evident that the groups in the Extended course spend more time on the verbal representation, and on modelling and the physical representation (drawing the FBD) than do the groups in the Mainstream course.

**Table 10.2: The time spent by the lecturers and the students while tackling a Newton’s 2<sup>nd</sup> Law physics task**

| <b>Pedagogical practices</b>         |                            | <b>How students tackle the task</b>   |   |
|--------------------------------------|----------------------------|---|---|
| <b>Mainstream course</b>             | <b>Extended course</b>     | <b>Mainstream course</b>  | <b>Extended course</b>  |
| <i>Verbal representation</i>         |                            | <i>Verbal representation</i>  |   |
| 1.5 minutes                          | 10 minutes for 2 instances | Group 1: 30 seconds<br>Group 2: 2 minutes                                     | Group 1: 5 minutes<br>Group 2: 5.5 minutes                                  |
| <i>Modelling of the problem</i>      |                            | <i>Modelling of the problem</i>   |   |
| 0 minutes - no modelling             | 9 minutes for 3 instances  | Group 1: 0 minutes - no modelling<br>Group 2: 3 minutes                       | Group 1: 3 minutes for 2 instances<br>Group 2: 3 minutes for 2 instances    |
| <i>Physical representation - FBD</i> |                            | <i>Physical representation - FBD</i>  |   |
| 5 minutes                            | 12 minutes for 2 instances | Group 1: 5 minutes<br>Group 2: 4.5 minutes for 2 instances                    | Group 1: 9 minutes for 4 instances<br>Group 2: 12.5 minutes for 4 instances |
| <i>Mathematical representation</i>   |                            | <i>Mathematical representation</i>  |   |
| 4 minutes                            | 4 minutes                  | Group 1: 26.5 minutes for 2 instances<br>Group 2: 9.5 minutes for 2 instances | Group 1: 29 minutes for 3 instances<br>Group 2: 12 minutes for 3 instances  |
| <i>Assess the problem</i>            |                            | <i>Assess the problem</i>   |   |
| No assessment                        | 1 minute                   | Group 1: no assessment<br>Group 2: no   | Group 1: no assessment<br>Group 2: 2 minutes                                |

|                         |            |                         |                     |
|-------------------------|------------|-------------------------|---------------------|
|                         |            | assessment              |                     |
| <i>Total time taken</i> |            | <i>Total time taken</i> |                     |
| 10.5 minutes            | 36 minutes | Group 1: 32 minutes     | Group 1: 48 minutes |
|                         |            | Group 2: 19 minutes     | Group 2: 34 minutes |

The semantic profiles and the data tables show that there is significant correspondence between the pedagogical practices and the ways in which students approach physics tasks in the Mainstream and Extended courses. In other words, the pedagogical practices influence how students tackle physics tasks. This may seem like an obvious finding, viz. that students are influenced by or ‘mimic’ what is presented in lectures. However, the research literature indicates that lecturers often do not take this into account in their teaching: the use of representations in solving physics problems is often not made sufficiently explicit to students (Van Heuvelen, 1991a) and mathematical representations often dominate classroom teaching (Leonard et al., 1996). This research literature further suggests that, if students are given time to practice working with different representations during teaching time, they are then more likely to use them in their own learning, and begin to ‘think like a physicist’ (see, for example, Van Heuvelen, 1991a). The implications of this are discussed more fully in the section below.

#### **10.4 Educational affordances of the Extended Physics course’s pedagogical practices**

This study set out to examine the educational affordances that the ‘extra time’ in the Extended course might allow. In other words, the study goes beyond a simple comparison of the Mainstream and Extended courses to examine whether the ‘extra time’ in the Extended course does in fact lead to different pedagogical practices and student learning outcomes in relation to the more traditional Mainstream course.

This section will discuss how the pedagogical practices in the Extended course differ from those in the Mainstream course. These differences are partly due to the extra time allocated to the Extended course, which allows the lecturer to draw on physics curriculum reforms. However, the data indicate that, even when the pacing is similar

in the two courses (see Chapter 5 – Section 5.2 and Table 5.1), the Extended course’s pedagogical practices nevertheless include different aspects. These have some implications for the teaching and learning of undergraduate physics and for extended courses in particular. These implications are discussed in relation to the relevant research literature.

#### *10.4.1 Linking to familiar concepts*

Drawing on Lindstrøm’s (2010) framework in this study, when familiar concepts or principles of physics are linked to more abstract, condensed representations or to the concrete context, this is referred to as the Linking level; therefore, this study suggests that it is fundamental in teaching physics to make use of this Linking level as a stage to illustrate explicitly the transition from Concrete to Abstract or vice versa.

The data showed that more time is spent linking to the Concrete level in the Extended lectures than in the Mainstream ones. Even when both the Mainstream and Extended lectures start at the Linking level, the entry point in the Mainstream course is oriented to a more abstract level, whereas the entry point in the Extended course is oriented to qualitative, concrete contexts.

Interestingly, as noted in Chapter 2, these qualitative, concrete contexts are important to experienced physicists (Van Heuvelen, 1991a). Physicists use metaphoric representations and condensed abstract physics concepts, which are regarded as a form of ‘technical language’, to reason productively. Therefore, starting or ending at the *level of the concrete context* or using familiar concepts in the pedagogical practices will help students to use the Linking level in relating their everyday understanding to the technical meaning of physics. Brookes (2006) notes that the different metaphors used in physics have their ‘own applicability and limitations’, hence it is valuable that lecturers be capable of presenting them (metaphors) in a ‘language and cognition that is *grounded in human experience*’ (Brookes, 2006: pp. 161-162; my italics). He also points out that,

From the metaphorical analysis of the language of physics it seems clear that part of the success of physics stems from the way in which *abstract concepts are metaphorically elaborated as familiar substances*. Learning physics is more than using equations to

solve back of chapter problems. It is also more than gaining an understanding of concepts or a deep understanding of the connections between concepts (Brookes, 2006: p. 175, *my italics*).

In other words, learning physics has to do with the ability to link concrete to abstract concepts, which is, to connect the everyday experience to the new principles of the discipline. DiSessa (1993) notes that students' knowledge and reasoning rely more on the context, whereas experienced physicists reason more in terms of principles and concepts. As Maton points out,

'translating' a technical term into commonsense understandings reduces its range of meanings, but that is the purpose: to provide a point of entry for noviciates into those meanings. This also represents a potential starting point for progressively strengthening its semantic density through elaborating, extending and refining additional meanings, such as by locating the term within systems of composition, taxonomies, and processes (Maton, 2013: p. 19).

The findings of my study emphasise the importance of the Linking level in pedagogical practice, as a means of linking the Concrete with the Abstract level. This implies that the lecturer has to connect the real-life context by 'repacking' the familiar into a technical expression or representation. However, it is easy for the lecturer to assume that, if they are using concepts that are familiar to students in order to simplify dense physics concepts, they have included the Concrete level, even though the focus of the shifts would be merely a sequence of Linking-Abstract/Abstract-Linking shifts. This would be due to not recognizing that the concepts are not in the students' everyday experience, but that the students merely recognize the concepts from their previous educational experiences. Therefore, referring to familiar concepts in this case would be characterised at a Linking level, and not at a Concrete level. This is because the familiar concepts being used are already condensed or abstracted; that is, SD is already strengthened and SG is weakened. Therefore, in Chapters 6 and 7, these familiar concepts are characterised within the Linking level. Buncick, Betts and Horgan (2001) term this linking or 'movement' between Concrete and Abstract levels, as 'connectivity' and explain it in this way:

Connectivity means that the curriculum makes links to students' concrete experiences, and that course concepts are not taught in isolation but in relation to one another and to everyday physical phenomena in which they play a part. Connectivity is fundamental to

both engagement and inclusivity: when students can relate to the material, they are in a position to participate. Conventional teaching (where concepts are too often abstracted from everyday physical phenomena and presented as isolated principles) is more likely to result in a limited dialog between the teacher and a few ‘stars’ who are most comfortable with the abstract language and imagery of the more experienced scientist (Buncick et al., 2001: pp. 1237-1238).

Georgiou similarly argues that,

A lack of connectivity has been associated, convincingly, with not only student difficulties, but also with attitudes about physics..... that facilitating the connectivity should encourage deeper understanding of physics (and a better attitude towards it) (2014b: p. 206).

#### 10.4.2 Use of examples

One issue that arises from the analysis of the pedagogical practices is the educational use of examples in physics. In the Extended lecture sequences, many of these examples were coded as Concrete (Figures 6.2 and 7.2). This was when the examples were either used as concrete demonstrations or illustrations to introduce a new physics concept, or to relate a physics concept to a concrete real-life situation. However, for much of the time in the Mainstream course (Figures 6.1 and 7.1), the examples were in the form of verbal problem statements, which were introduced in order to build towards the Abstract level. As mentioned in Chapter 2, these problem statement examples are already abstracted from the concrete, through being ‘*abstract verbal representations*’, which are then linked to ‘*more abstract mathematics representations*’ (Rosengrant et al., 2009: p. 010108-2). Hence this use of example is classified at the Linking level. Not all examples in the Extended course’s lectures were used in a concrete manner; some were also of the ‘verbal problem statement’ kind (the particular physics tasks in the Mainstream and Extended course chosen for analysis in Chapter 8 are both ‘problem statement type’ examples).

In summary, then, not all examples will automatically fall into the Concrete category; the context of how the example is used is important too. The findings in this study suggest that examples are used in different ways: they are used as concrete demonstrations or illustrations to introduce a new physics concept, or to relate a

physics concept to a concrete real-life situation. This seemed to be an important implication for this study. Lecturers might claim that, '*I use so many examples in class*', but the question one has to ask is, how the examples are being used, i.e. whether they are used in a Concrete or a Linking way. This study would argue that learning at the introductory physics level takes place when initially situated at the Concrete level, as Lindstrøm (2010) has noted (see Chapter 3, section 3.6.4).

#### *10.4.3 Making the tacit explicit*

PER suggests that, if students are to learn physics successfully, they are required not only to understand the content, but they also have to take on the discipline-specific practices and ways of thinking of physics. Such an approach also takes on the ways in which the physics community engages with disciplinary knowledge (for example, Etkina & Van Heuvelen, 2007; Van Heuvelen, 1991; Wieman & Perkins, 2005), by viewing physics learning as a way of accessing a disciplinary discourse (Airey & Linder, 2009), as pointed out in Chapter 2. Therefore, if students are to be inducted into the broader disciplinary community of practice, then they have to be taught how to use the disciplinary discourse (Enghag et al., 2013).

#### *10.4.4 The explicit use of representations*

As shown in Chapter 2 (the PER literature), traditionally in physics, students are expected to learn to move effortlessly between different representations (e.g. from verbal descriptions to pictorial representations, as well as to symbolic and mathematical representations), but this is often not made sufficiently explicit in the pedagogy. There was more evidence of these pedagogical moves between representations in the Extended course than in the Mainstream course. The Extended lecture sequence moreover showed evidence of a slower and more explicit moving between representations. In the Extended course's semantic profile (Figure 8.2), there is a more explicit focus on interpreting the verbal representation of the concrete problem situation, before modelling the problem and constructing a careful physical representation (a FBD), and finally moving on to the mathematical representation. Conversely, in the Mainstream course's semantic profile (Figure 8.1), there is a swift shift away from the concrete problem situation in terms of weakening SG and

strengthening SD, or rapidly condensing the meaning of the problem context into mathematical representation. There is also more focus in the Extended lecture sequences on developing ‘metarepresentational competence’ (Kohl & Finkelstein, 2008), by focusing explicitly on the purposes of various representations and ‘knowing what different representations are useful for’ (p. 010111-11).

In LCT terms, there was greater movement up and down the semantic continuum (‘downshifting and upshifting’) in the Extended lecture sequences, with more explicitness in explaining and condensing (‘unpacking & repacking’) the concepts. The concepts of SG and SD – combined to form a semantic profile – offered a useful way of describing and mapping the pedagogical moves between representations. Macnaught, Matruglio, Maton and Martin (2013: p. 62) argue that this kind of teaching, where the lecturer is guiding the students explicitly by moving up and down the semantic continuum, gives students the chance to practice ‘new understandings as they gradually learn to capture more of the meaning potential in the power words that are circulating in their classrooms’.

#### *10.4.5 Semantic flow*

As noted earlier, the semantic profiles for the Mainstream lecture sequences show that, in some parts, there are discontinuities between the semantic shifts. At these points, the lecturer will leave the previously learned concept and start with a new application, without explicitly relating what he is currently doing to the theoretical concept dealt with earlier. This is not to suggest that there is no implicit link, but merely that the link was not explicitly pointed out. Shay and Steyn (2015) refer to this as ‘upshifting’, where theorising is emphasised, and where applications are used to build towards theory. As mentioned in Chapter 3, Maton argues that, in a pedagogical practice, there should be both ‘downshifting and upshifting’ in ‘unpacking and repacking’ the concepts, in order to relate ‘technical concepts to everyday examples’ and to ‘condense meaning to abstract theoretical ideas’ (Maton, 2014c: p. 192).

#### *10.4.6 Explicitly building on prior knowledge*

As Maton (2009) argues, building on previously learned knowledge is a key aspect of ‘cumulative learning’, where the ‘understandings integrate and subsume previous knowledge, [and] new ideas or skills build on past knowledge’ (p. 44). As pointed out in Chapter 7, the semantic profile cannot capture the details of how the prior knowledge was built on, in other words, to distinguish whether the prior knowledge comes from an earlier part of the same lecture, from a previous lecture, from a related subject (e.g. Mathematics – vectors, integration), from school physics or from wider everyday contexts. The semantic profile only indicates a shift between Concrete and Linking, or between Linking and Abstract, but not the details of this. Hence, it is important for the lecturer to show explicitly the conceptual unity or, in LCT terms, the semantic shifts between Concrete, Linking and Abstract, since the students lack this ability of seeing, acquiring and processing the ‘knowledge organisation’ or ‘knowledge hierarchy’ of the discipline of physics when they seek to make meaning (Van Heuvelen, 1991a: p. 894). If lecturers are reinforcing this notion of understanding the conceptual unity, by showing explicitly how to revisit the basic ideas repeatedly and by building upon them (cf. Bruner’s [1966] ‘spiral curriculum’), this ‘overt systematic instruction’ (Tang & Moje, 2010: p. 82) will provide a relevant pathway that leads students towards a ‘discursive fluency’ in the modes of the disciplinary discourse of physics (Airey & Linder, 2009: p. 27). In other words, moving up and down the semantic continuum or moving between representations will become ‘almost second nature’ to the students (Airey & Linder, 2009: p. 33).

#### *10.4.7 Use of teaching and learning materials*

As mentioned in Chapter 7, the semantic profile cannot indicate whether the lecturer is using teaching and learning materials (i.e. class handouts, course reader, the students’ own summary notes or textbooks) when there are semantic shifts between the Concrete, Linking and Abstract levels. In the Extended course, it was observed that teaching and learning materials are used in particular ways as artefacts for scaffolding the semantic shifts, for instance by referring to and reading class notes/handouts and the textbook while teaching, as well as by writing notes on the board/OHP and asking students to write their own notes in their books. As shown in



Chapters 1 and 5, focusing on helping students to ‘think like physicists’ (Etkina & Van Heuvelen, 2007) by guiding them through the process of making explicit the ways in which the disciplinary knowledge is represented is the main philosophy of the Extended course.

#### *10.4.8 The role of interactive engagement*

As shown in Figures 10.1 and 10.2, the pedagogical practices had a significant influence on how the students tackled the physics tasks. There was more frequent shifting up and down the semantic continuum in the Extended lecture sequences, and this was also reflected in the students’ semantic profiles. The line thickness coding in the semantic profiles of the pedagogical practices indicates that there was much more student participation in the Extended course lectures when moving between the semantic levels, which means that the students were actively involved in the semantic shifts. As noted earlier, the communicative approaches (Mortimer & Scott, 2003) in the lectures varied, with a less interactive approach in the Mainstream course and a more interactive-dialogic approach in the Extended course lectures.

In the Extended lectures, students were more involved in class in moving between representations, and they were also given time to practice constructing representations and moving between them. Then, when tackling the physics tasks, these students tended to adopt a greater modelling approach in their tasks, and to use qualitative physics representations in more sophisticated ways. These students approached the physics tasks ‘like a physicist’ because they were in a ‘representation-rich learning environment, which helps students to learn how to use different representations’ (Rosengrant et al., 2009: p. 010108-2); consequently, they consciously used the representations to reflect on their work (see the details of this in Chapter 2).

Conversely, both groups from the Mainstream course displayed a more mechanical approach to the problem tasks, because they mainly focused on the mathematical representation of the task; as Rosengrant et al. (2009) noted in their study, the students just followed the steps they had learned in the classroom without having a full understanding of the importance of each step. Furthermore, in this study, the inadequate conceptual understanding of Newton’s 2<sup>nd</sup> Law among the Mainstream

groups was seen to inhibit their use of the FBD as a tool to guide their mathematical representation.

As noted in Chapter 2 on PER, IE in physics education is seen to be important for improving students' conceptual understanding (Hake, 1998). At times, the groups from the Mainstream course seemed to struggle with conceptual understanding. For example, one Mainstream group seemed to lack an understanding of the modelling implicit in a point particle representation, and felt that a point particle was 'confusing'. They preferred to work with a sketch of the object of interest. Interestingly, as shown in the semantic profile for the pedagogical practice (Figure 8.1), the point particle model from a physics perspective was taken for granted, as the lecturer did not model the object of interest as a point particle. Also, as shown in all the semantic profiles of the Mainstream course, most of the time, there was a 'non-interactive communicative approach' in these lecture sequences. Research suggests that, if students are not in a conceptual learning environment, which enables them to discuss their conceptual difficulties and understanding, their conceptual development will be constrained (Shaffer & McDermott, 1992).

#### *10.4.9 Summary of differences in introductory physics pedagogical practice*

This section has discussed how the differences in the pedagogical practices of the Mainstream and Extended courses are partly due to the extra time allocated to the Extended course. However, the data indicates that, even when the pacing is more similar in the two courses (as indicated by the similar compression in semantic profiles in Figures 7.1 and 7.2), there were differences in pedagogical practices. These included greater shifting up and down the semantic continuum, use of examples in different ways, greater use of IE, and more explicit use of representations.

### **10.5 Methodological contributions of the study**

The *first* contribution of this study is to link LCT to physics education research (PER) and to research on epistemological access and academic literacies, in a novel way. To do so, I began with a general framing of epistemological access to the disciplinary knowledge. I coupled this with perspectives from the field of academic literacies.

Epistemological access was framed in terms of acquiring the ‘academic literacies’ of a discipline (which Linder et al. [2014] term ‘disciplinary literacy’) that allow one to participate in the discourse of that discipline (Arbee, 2012). Epistemological access entails engagement with both the content knowledge and with the ways of knowledge development in that discipline (Boughey, 2005). Since this is a PER project, the study then looked at how epistemological access is taken up in the PER literature. It was important for this study to review literature which examines how physics as a discipline represents knowledge in multiple representations (i.e. by moving between abstract and concrete constructs). I therefore utilized the PER literature to complement the LCT analysis. The Semantics dimension of LCT was used as an analytical tool to characterize the pedagogical practices and students’ learning in this introductory physics context. The LCT concepts of SG and SD seemed well-suited to characterizing the moves between abstract and concrete constructs in physics, as well as to exemplifying the nature of the representations used in physics. The study has shown the usefulness of LCT for analysing and understanding pedagogical practices and students’ learning.

The *second* contribution of this study has been to extend and elaborate on the characterization of the semantic shifts through semantic profiling, as developed by Maton (2013). Within the context of physics, this study has developed two different forms of semantic profiles:

- one, which maps how the strengths of SG and SD vary over time in lecture sequences (pedagogical practices);
- another, which maps how the strengths of SG and SD vary, as lecturers and students use various representations in dealing with physics tasks.

Maton emphasizes that semantic profiles are not all identical; they have ‘*subject-specific forms*’ (Maton, 2014b: p. 45, my italics), and as shown by the two forms of semantic profiles above, semantic profiles may differ even within a discipline, depending on the context (a lecture sequence or a particular physics task). To construct these semantic profiles, two different languages of description (LoDs) were developed, one for analysing pedagogical practices of a lecture sequence (LoD1), and a different one for analysing the particularities of a physics task (LoD2).

The LoD for analysing pedagogical practices (LoD1) extends Lindstrøm's (2010) characterization of semantic shifts, using the Linking level. My study has shown the importance of the Linking level in physics teaching, when moving between the Abstract and Concrete Levels. Lindstrøm's study analysed a small part of a lecture, whereas this study analyses entire lecture sequences. The LoD for analysing physics tasks (LoD2) drew on physics education frameworks on representations (Knight, 2007; Van Heuvelen, 1991a), which were used in relation to SG and SD. This was done to map the lecturers' pedagogical modes and the students' approaches in moving 'back and forth' between multiple representations when tackling physics tasks.

In both forms of the semantic profile, the study has modified Maton's form of semantic profiling, through introducing a more detailed *time scale* and *gradations of semantic strength*. This aims to address Maton's concern that more research is needed to develop 'sophisticated instruments for calibrating typological scales of strength with precision' (Maton, 2014c: p. 186). As Clarence (2014) notes as a limitation of her study, semantic profiles 'can seem a little vague rather than concrete and exactly measurable' (p. 173). This study has attempted to address this shortcoming through the introduction of the time scale, as well as gradations on the semantic scale, which characterise levels between the SG/SD poles on the continuum.

The study has also modified Maton's form of semantic profiling, using coding to map the *form of communicative approach* used in the lecture – specifically, whether it is non-interactive, or more interactive dialogic. PER (see Chapter 2) suggests that this would matter – viz. whether the students are themselves engaging in moving up and down the semantic continuum and moving between representations, or whether they are being shown by the lecturer how to do this. Since interactive pedagogical practices have been shown to be important for physics learning, in other words, for 'students' successful mastery of [the discipline's] organizing principles' (Maton, 2014b: p. 46), mapping student engagement in the semantic profile is helpful.

## 10.6 Conclusion

This chapter has brought together the research findings from Chapters 6 to 9 into one cohesive discussion. The chapter has discussed how the two research questions have been addressed in this study, and has discussed what have been seen as the implications of this research for the teaching and learning of university physics. The final chapter will conclude the study, discuss the implications of this research for the Extended programmes and outline possible future areas for research work.



# Chapter 11:

## Conclusion

### 11.1 Introduction

The study has taken the form of a case study of two introductory physics courses within a Physics Department that has a longstanding commitment to undergraduate teaching (see Chapter 1). The Mainstream course was seen as a benchmark of typical, traditional first year physics teaching. The study sought to investigate the educational affordances of the Extended course, with its extra curriculum time. To do so, the study used the Semantics dimension of LCT to examine the pedagogical practices and student learning in the Extended introductory physics course, in relation to the Mainstream course. The study also drew on physics education literature, which examines students' difficulties with using multiple representations in Mechanics.

The study has shown that the extra time enabled different *pedagogical practices* in the Extended course as compared to the Mainstream one. The Extended course showed a steady progression in pacing, moving from a less compressed semantic profile earlier in the academic year to a more compressed semantic profile later. The Extended course's semantic profiles show more evidence of the Linking level being used to move between Abstract and Concrete levels, and more time being spent at the Concrete level. There was also greater semantic flow (i.e. there were no discontinuities) in the Extended course's semantic profiles, indicating a more explicit movement up and down the semantic continuum. The semantic profile was also used to indicate different communicative approaches in the two courses, with students more engaged in making the semantic shifts together with the lecturer in the Extended course. The educational use of examples in the two courses was rather different too: the Extended course used more real-life illustrations as a starting point (these were classified at the Concrete level), whereas the Mainstream course tended to use verbal problem statements (classified at the Linking level), which were introduced in order to build towards the Abstract level.

Looking particularly at how *problem tasks* were dealt with, the study showed that the lecturers' pedagogical practices in dealing with physics tasks influenced the ways in which the students tackled these. The study showed a more rapid shift up the semantic continuum to mathematical representations in the Mainstream course's pedagogy and student work. In the Extended course's pedagogy and student work, more time was spent initially unpacking the problem situation and moving between qualitative and quantitative representations; in other words, these students began to show elements of what Van Heuvelen terms 'thinking like a physicist' (Van Heuvelen, 1991a).

In summary, the strength of LCT as the chosen analytical framework for this study lies in its capacity, through semantic profiling, to provide visual display of moves between Abstract, Linking and Concrete levels, and between different representations in pedagogical practices and student learning. The time dimension of the semantic profiles enables a visual portrayal of pacing in the lectures, as well as simultaneously a portrayal of the forms of student-lecturer interaction in lectures.

## **11.2 Implications for extended programmes**

This study holds certain implications for the development of Extended courses in the South African context, where extended four-year BSc degrees are being mooted (CHE, 2013). If implemented, this would mean that extended BSc degrees would become the norm for most students.

As mentioned in Chapters 1, 4 and 5, in the context of the study, the Extended course was designed to help students access the disciplinary discourse of physics, in other words, to enable epistemological access to the discipline. As shown in the semantic profiles of this study, the Extended course's pedagogy does not just provide 'extra time' to cover the curriculum, but also 'extra time' to be explicit about representations, or, in LCT terms, to 'unpack and repack' representations through strengthening and weakening the SG and SD. That is, the extended curriculum structure allows more time for the sort of physics teaching advocated by the PER literature (for example, Etkina & Van Heuvelen, 2007; Mazur, 2009; Van Heuvelen,

1991a) and the sorts of capabilities physics graduates would be expected to have (CHE-SAIP, 2013; IOP, 2010; QAA, 2002).

Kloot et al. (2008) note that extra time is not sufficient alone: rather, it is how the time is used. They note that the most basic feature of foundation or extended programmes is 'more time, more tuition', but that the extra time should not merely be spent doing the mainstream curriculum more slowly. As Allie (1987) notes, 'simply going more slowly certainly benefits some students, but it does not necessarily lead to students becoming independent learners' (p. 135). Similarly, Dancy & Henderson (2010) note that, while 'time' is often seen by physics lecturers as a hindrance to implementing innovative pedagogical practices, having more time does not necessarily mean that lecturers will adopt different teaching approaches.

As indicated above, the extra time in the Extended course, with less pressure to cover content, allowed for teaching that could be more responsive to the students' perceived needs. As shown in the data and in the coding of the semantic profiles, in the Mainstream course, the lecturer strongly controlled the pacing of the content, whereas in the Extended course, the 'extended first year' model gave the lecturer more time to set up in-class activities for students, and to respond to students' questions and difficulties. In other words, there was more student control of pacing in the Extended course as compared to the Mainstream course (or, in Bernstein's terms [Bernstein, 2000], a weaker framing of pacing). This has also been noted in other science classroom studies; for example, Morais and Neves (2011) show that, where there is weaker framing of pacing and more time for interaction between teachers and students (i.e. weaker framing of hierarchy), student learning is optimized. This reciprocal relationship between lecturer and student could be viewed in terms of 'pedagogical resonance' (Trigwell & Shale, 2004), where the lecturer is responsive to the students' needs.

For the context of my study, the implication would be to use the time to implement pedagogical practices that make the disciplinary discourse more explicit and that enable epistemological access. This would imply more shifting up and down the semantic continuum, in other words, moving between concrete examples or



demonstrations and abstract physics principles. As Georgiou (2014b) notes, this ‘connectivity’ between abstract and concrete – through curriculum and pedagogy – is associated not only with students’ deeper understanding of physics but also with improved student engagement and positive attitudes towards physics.

One of the concerns raised with regard to extended programmes is that staff capacity is needed in order to approach teaching and learning differently. Staff need to be able to engage in the scholarship of teaching and learning in their discipline, and to engage with the discipline-based science education research literature (for example, Singer, Nielsen & Schweingruber, 2012). With regard to the implementation of extended programmes, Boughey (2010b) notes that the academic staff need to take on identities as professional educators. In this case study, it was notable that the Extended lecturer had completed a Masters in Science Education and had thus been exposed to curriculum initiatives in the PER literature. This exposure enabled a ‘crafting’ of teaching practice (Linder & Fraser, 2009), ‘aimed at enhancing the possibility of learning’ (p. 39) and enabling epistemological access. As numerous studies have shown, cultural conditions in universities – which tend to privilege research in relation to teaching – may limit the emphasis placed on developing the teaching capacity of staff (for example, Boughey, 2009; Kloot et al., 2008; Kotta, 2011).

### **11.3 Implications for future research**

The introductory Extended physics course is only one part of the physics undergraduate programme. One question that this study raises is how well the Extended course prepares students for the *transition to second year physics*. The analysis of student physics tasks in Chapter 9 showed that the students in the Extended course tackled physics tasks differently to those in the Mainstream course. The former tended to adopt a greater modelling approach in their tasks, and used more qualitative physics representations before moving on to mathematical representations. These students thus approached the physics tasks ‘like a physicist’ because they were in a ‘representation-rich learning environment, which helps students to learn how to use representations’ (Rosengrant, et al., 2009: p. 01018-2). The analysis in Chapter 9 showed that the ways in which the tasks were designed and assessed furthermore

emphasised different modes of representations: in the Extended course, the marking memorandum showed a greater emphasis on students explicitly showing how they had modelled the situation before proceeding to the mathematical representation.

Future research needs to be conducted into the transition to second year physics, when the students in both the Mainstream and the Extended course are in the same class. Traditional second year Physics often places a much greater emphasis on mathematical representations, with the other qualitative representations taken for granted and not explicitly emphasised in either teaching or assessment. Students from the Extended course may experience a mismatch between what was valued in first year and what is valued in the second year assessment. Other studies have also analysed this transition from an extended programme into a mainstream second year course. Smith, Case and Walbeek (2014), in their assessment of the effectiveness of academic development programmes, show that these programmes significantly influenced students' performance in the first year but did not improve the overall graduation rate of students. They question 'the efficacy of a model that focuses largely on first year academic interventions' (p. 636). Others have suggested that changes to the curricula and pedagogies beyond the first year are what are needed (for example, Rollnick, 2010). Lubben (2007) similarly noted that physics students struggled with the discontinuity in teaching approaches between the extended courses and the mainstream physics courses.

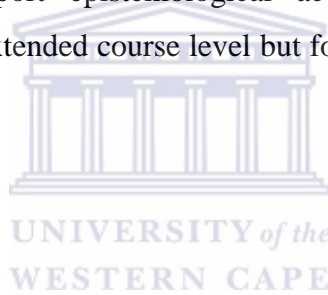
Another direction for future research would be to explore in greater depth what constitutes 'abstract' and 'concrete', particularly in more senior Physics courses which become more mathematically-based. Here, the work of Hestenes (1992) on modeling games and the work of Podolefsky & Finkelstein (2007) on the role of concrete and abstract representations in learning abstract concepts would be relevant. The parallels between their blended use of abstract and concrete signs and the Linking level in LCT could be productively explored.

Future research might also explore LCT in relation to other theoretical frameworks that examine the crafting of pedagogical practice, for example variation theory (Marton & Booth, 1997). In this perspective, the lecturer would identify the critical

aspects of a phenomenon to be learned and then would vary these, while keeping other aspects invariant. It would be useful to examine this in relation to varying semantic gravity and semantic density in LCT. Similarly, it might be interesting to explore parallels between teachers' pedagogical content knowledge (Schulman, 1986) and the semantic profiles of their pedagogical practices.

In conclusion, this study has investigated the educational affordances of the Extended course, with its extra curriculum time. Using LCT semantic profiling, it has characterised the different pedagogical practices observed in the Extended and the Mainstream courses, and shown that these made different forms of learning possible, as shown in students' approaches to physics tasks.

These findings have important implications for how curriculum and pedagogical practices might better support epistemological access to physics disciplinary knowledge, not only at the Extended course level but for introductory physics courses more generally.



## References

- Airey J., & Linder, C. (2009). A disciplinary discourse perspective on university science learning: Achieving fluency in a critical constellation of modes. *Journal of Research in Science Teaching*, 46, 27-49.
- Allen, J. D. (1995). The use of case studies to teach educational psychology: A comparison with traditional instruction. Paper presented at *AERA Annual Conference*, April 18-22, in San Francisco, CA (ERIC Document Reproduction Service No. ED387491).
- Allie, S. (1987). The physics foundation course at UCT. *Proceedings of the 8<sup>th</sup> Academic Support Programmes Conference*, Rhodes University, Grahamstown.
- American Association of Physics Teachers, New England Section Meeting (1996). *Interactive Lecture-Tutorials in the introductory physics course for non-science majors at the University of Maine*. Amherst, Massachusetts, November 1996.
- Arbee, A. (2012). *Knowledge and knowers in the discipline of marketing at the University of KwaZulu-Natal* (Unpublished doctoral thesis), University of KwaZulu-Natal, South Africa.
- Ausubel, D. (1968). *Educational psychology: A cognitive view*. New York: Holt, Rinehart & Winston.
- Ballard, B., & Clanchy, J. (1988). Literacy in the university: An anthropological approach. In G. Taylor (Ed.), *Literacy by Degrees* (pp. 7-23). Milton Keynes: Society for Research into Higher Education and Open University Press.
- Beichner, R. J. (1994). Testing student interpretation of kinematics graphs. *American Journal of Physics*, 62(8), 750-762.
- Beichner, R. (2008). *The SCALE-UP Project: A student-centered, active learning environment for undergraduate programs. An invited white paper for the National Academy of Sciences*. Retrieved from [http://www7.nationalacademies.org/bose/Beichner\\_CommissionedPaper.pdf](http://www7.nationalacademies.org/bose/Beichner_CommissionedPaper.pdf).

- Beichner, R., Bernold, L., Burniston, E., Dail, P., Felder, R., Gastineau, J., Gjertsen, M., & Risley, J. (1999). Case study of the physics component of an integrated curriculum. *American Journal of Physics*, 67(7), S16-24.
- Bennett, S. (2002). *Learning about design in context: An investigation of learners' interpretations and use of real life cases within a constructivist learning environment created to support authentic design activities* (Unpublished doctoral thesis), University of Wollongong, Australia.
- Bernstein, B. (1973). A brief account of the theory of codes. *Social Relationships and Language: Some Aspects of the Work of Basil Bernstein*, Reading: Open University Press.
- Bernstein, B. (1975). *Class, codes and control: Volume 3. Towards a theory of education transmissions* (2<sup>nd</sup> ed). London: Routledge & Kegan Paul.
- Bernstein, B. (1999). Vertical and horizontal discourse: An essay. *British Journal of Sociology of Education*, 20(2), 157-173.
- Bernstein, B. (2000). *Pedagogy, symbolic control and identity: Theory, research, critique* (revised ed.). Oxford: Rowman & Littlefield.
- Boughey, C. (2002). 'Naming' students' problems: An analysis of language-related discourses at a South African university. *Teaching in Higher Education*, 7(3), 295-307.
- Boughey, C. (2005). 'Epistemological' access to the university: An alternative perspective. *South African Journal of Higher Education*, 19(3), 230-242.
- Boughey, C. (2007). Educational development in South Africa: From social reproduction to capitalist expansion? *Higher Education Policy*, 20, 5-18.
- Boughey, C. (2008). Texts, practices and student learning: A view from the South. *International Journal of Educational Research*, 47(3), 192-199.
- Boughey, C. (2010a). Understanding teaching and learning at foundation level: A 'critical' imperative? In C. Hutchings and J. Garraway (Eds.), *Beyond the university gates: Provision of extended curriculum programmes in South Africa* (pp. 4-10). Rhodes University: HELTASA.
- Boughey, C. (2010b). *Academic development for improved efficiency in the higher education and training system in South Africa*. Pretoria: Development Bank of Southern Africa.

- Boughey, C., & Van Rensburg, V. (1993). Writing to learn in occupational therapy. *AD Dialogues*. Bellville: University of the Western Cape.
- Brookes, D. T. (2006). *The role of language in learning physics* (Unpublished doctoral thesis), The State University of New Jersey, United States.
- Brookes, D. T., & Etkina, E. (2007). Using conceptual metaphor and functional grammar to explore how language used in physics affects student learning. *Physical Review Special Topics: Physics Education Research*, 3, 010105.
- Bruner, J. S. (1960). *The process of education*. Cambridge, Mass: Harvard University Press.
- Bruner, J. S. (1966). *Toward a theory of instruction*. Cambridge, Mass: Belknap Press of Harvard University.
- Bruner, J. S. (2006). *In search of pedagogy: The selected works of Jerome S. Bruner*. Abingdon, England: Routledge.
- Buncick, M. C., Betts, P. G., & Horgan, D. D. (2001). Using demonstrations as a contextual road map: Enhancing course continuity and promoting active engagement in introductory college physics. *International Journal of Science Education*, 23(12), 1237-1255.
- Calderhead, J. (1981). Stimulated recall: A method for research on teaching. *British Journal of Educational Psychology*, 51, 211-217.
- Case, J. M., & Light, G. (2011). Emerging methodologies in engineering education research. *Journal of Engineering Education*, 100(1), 186-210.
- Chen, R. (2010). *Knowledge and knowers in online learning: Investigating the effects of online flexible learning on student sojourners* (Unpublished doctoral thesis), University of Wollongong, Australia.
- Clarrence, S. (2014). *Enabling cumulative knowledge-building through teaching: A Legitimation Code Theory analysis of pedagogical practice in Law and Political Science* (Unpublished doctoral thesis), Rhodes University, South Africa.
- Cohen, L., & Manion, L. (1980). *Research methods in education*. London: British Library Cataloguing in Publication Data.
- Cohen, L., Manion, L., & Morrison, K. (2000). *Research methods in education* (5th ed.). London: Routledge/Falmer.

- Council on Higher Education (CHE). (2013). A proposal for undergraduate curriculum reform in South Africa: The case for a flexible curriculum structure. Report of the Task Team on Undergraduate Curriculum Structure. Retrieved from:  
[http://www.che.ac.za/media\\_and\\_publications/research/proposal-undergraduate-curriculum-reform-south-africa-case-flexible](http://www.che.ac.za/media_and_publications/research/proposal-undergraduate-curriculum-reform-south-africa-case-flexible).
- Council on Higher Education and South African Institute of Physics (CHE-SAIP). (2013). *Review of undergraduate physics education in public higher education institutions*.
- Cousin, G. (2009). *Researching learning in higher education: An introduction to contemporary methods and approaches*. New York, NY: Routledge.
- Creswell, J. W. (1998). *Qualitative inquiry and research design: Choosing among five traditions*. London New Delhi: Sage Publications Inc.
- Damon, W., & Phelph, E. (1989). Critical distinctions among three approaches to peer education. *International Journal of Educational Research*, 13(1), 9-19.
- Dancy, M. H., & Henderson, C. (2010). Pedagogical practices and instructional change of physics faculty. *American Journal of Physics*. 78(10), 1056-1063.
- Department of Education. (2001). *National plan for higher education*. Ministry of Education. Pretoria: Department of Education.
- Deslauries, L., Schelew, E., & Wieman, C. (2011). Improved learning in a large environment physics lesson. *Science*, 332, 862-864.
- DiSessa, A. A. (1988). Knowledge in pieces. In G. Forman & P. Pufall (Eds.), *Constructivism in the computer age* (pp. 49-70). Hillsdale, NJ: Lawrence Erlbaum Associates, Inc.
- DiSessa, A. (1993). Toward an epistemology of physics. *Cognition and Instruction*, 10(2 & 3), 105-226.
- Driver, R., Asoko, H., Leach, J., Mortimer, E., & Scott, P. (1994). Constructing scientific knowledge in the classroom. *Educational Researcher*, 23, 5-12.
- Driver, R., & Easley, J. (1978). Pupils and paradigms: A review of literature related to concept development in adolescent science students. *Studies in Science Education*, 5(1), 61-84.
- Elby, A. (1999). Another reason that physics students learn by rote. *American Journal of Physics: Physics Education Research Supplement*, 67(7), S52-S57.

- Enghag, M., Forsman, J., Linder, C., MacKinnon, A., & Moons, E. (2013). Using a disciplinary discourse lens to explore how representations afford meaning making in a typical wave physics course. *International Journal of Science and Mathematics Education, 11*, 625.
- Etkina, E., & Van Heuvelen, A. (2007). Investigative science learning environment: A science process approach to learning physics. In E. F. Redish and P. J. Clooney (Eds.), *Research-based reform of university physics* (pp. 1-48). (AAPT, Compadre): American Association of Physics Teachers.
- European Commission. (2004). *Europe needs more scientists!* Brussels: Directorate-General for Research, High Level Group on Human Resources for Science and Technology in Europe.
- Finlay, L., & Ballinger, C. (2006). *Qualitative research for allied health professionals: Challenging choices*. England: Whurr Publishers Limited.
- Flyvbjerg, B. (2001). *Making social science matter: Why social inquiry fails and how it can succeed again*. Cambridge, UK: Cambridge University Press.
- Flyvbjerg, B. (2006). Five misunderstandings about case-study research. *Qualitative Inquiry, Sage Publications, 12*(2), 219-245.
- Fredlund, T. (2013). *Exploring physics education using a social semiotic perspective: The critical role of semiotic resources* (Unpublished Licentiate thesis), Uppsala University, Sweden.
- Fredlund, T., Linder, C., & Airey, A. (2014). Unpacking physics representations: Towards an appreciation of disciplinary affordances. *Physics Review Special Topics, 10*(2).
- Froyd, J. E. (2008). *White paper on promising practices in undergraduate STEM education*. Commissioned paper for the Evidence on Promising Practices in Undergraduate Science, Technology, Engineering and Mathematics (STEM) Education Project, The National Academies Board on Science Education, 2008. Retrieved from:  
[http://www7.nationalacademies.org/bose/Froyd\\_Promising\\_Practices\\_CommissionedPaper.pdf](http://www7.nationalacademies.org/bose/Froyd_Promising_Practices_CommissionedPaper.pdf).
- Garraway, J. (2010). Field knowledge and learning on foundation programmes. In C. Hutchings & J. Garraway (Eds.). *Beyond the university gates: Provision of extended curriculum programmes in South Africa* (pp. 59-75). HELTASA.



- Gee, J. P. (1990). *Social linguistics and literacies: Ideology in discourse*. London: Falmer.
- Gee, J. P. (1996). *Social linguistics and literacies: Ideology in discourse* (2<sup>nd</sup> ed.) London: Taylor & Francis.
- Geertz, C. (1973). Thick description: Toward an interpretive theory of culture. In C. Geertz (Ed.), *The interpretation of cultures* (pp. 3-30). New York: Basic Books.
- Georgiou, H. (2012). Using concepts from sociology to examine student understanding of physics: A pilot study. Paper presented at the 7<sup>th</sup> International Basil Bernstein Symposium, Aix-en-Provence, France.
- Georgiou, H. (2014a). Putting physics knowledge in the hot seat: The semantics of student understandings of thermodynamics. In K. Maton, S. Hood, & S. Shay (Eds), *Knowledge-building*. London: Routledge.
- Georgiou, H. (2014b). *Doing Positive Work: On student understanding of thermodynamics* (Unpublished doctoral thesis), University of Sydney, Australia.
- Georgiou, H., Maton, K., & Sharma, M. (2014). Recovering knowledge for science education research: Exploring the 'Icarus effect' in students work. *Canadian Journal of Science, Mathematics and Technology Education*, 14(3), 252-268.
- Golafshani, N. (2003). Understanding reliability and validity in qualitative research. *Qualitative Report*, 8(4), 59-607.
- Guba, E. G. & Lincoln, Y. S. (1981). *Effective evaluation*. San Francisco, CA: Jossey-Bass Publications, Inc.
- Guba, E.G. & Lincoln, Y.S. (1998) Competing paradigms in qualitative research. In *The Landscape of Qualitative Research* (Denzin N.K. & Lincoln Y.S., eds), Sage, Thousand Oaks, CA, pp. 195– 222.
- Hake, R. (1998). Interactive-engagement versus traditional methods: A six-thousand-student survey of mechanics test data for introductory physics courses. *American Journal of Physics*, 66(1), 64-74.
- Halliday, M. A. K. (1998). Things and relations: Regrammaticising experience as technical knowledge. In J. R. Martin, & R. Veel (Eds.), *Reading science: Critical and functional perspectives on discourses of science* (pp. 185-236). London: Routledge.

- Hammer, D., & Elby, A. (2000). Epistemological resources. In B. Fisherman & S. O'Connor-Divelbiss (Eds.), *Fourth International Conference of the Learning Sciences* (pp. 4-5). Erlbaum, Mahwah, NJ.
- Heller, P., & Hollabaugh, M. (1992). Teaching problem solving through cooperative grouping: Part 2 Designing problems and structuring groups. *American Journal of Physics*, 6, 637-644.
- Herbert, M., Conana, C., Volkwyn, T., & Marshall, D. (2010). Multiple modes of epistemological access in Physics. In C. Hutchings and J. Garraway (Eds.), *Beyond the university gates: Provision of extended curriculum programmes in South Africa* (pp. 8-23). HELTASA.
- Hestenes, D. (1992). Modelling games in the Newtonian world. *American Journal of Physics*, 60(8), 732.
- Hewitt, P. G. (1983). Millikan Lecture 1982: The missing essential: A conceptual understanding of physics. *American Journal of Physics*, 51(4), 305-311.
- Hewitt, P. G. (1998). *Conceptual Physics* (8<sup>th</sup> ed). San Francisco: Addison-Wesley Publishers.
- Hewson, P. W. (1982). A case study of conceptual change in special relativity: The influence of prior knowledge in learning. *European Journal of Science Education*, 4, 61-78.
- Hoadley, U. (2006). Analysing pedagogy: The problem of framing. *Journal of Education*, 40, 15-34.
- Holtman, L., & Marshall, D. (2008). Foundational provisions in the UWC Science Faculty: Widening access and promoting success. In L. Holtman, C. Julie, O. Mikalsen, & M. Ogunnyi (Eds.), *Some developments in science and maths education in Sub-Saharan Africa: Access, adoption, adaption and localization* (pp. 73-105). Cape Town: Compress Publishers.
- Holtman, L., Marshall, D., & Linder, C. (2004). Widening (epistemological) access: Two undergraduate science courses. In H. Griesel (Ed.), *Curriculum responsiveness: Case studies in higher education* (pp. 185-216). Pretoria: SAUVCA.
- Hugo, W., Bertram, C., Green, W., & Naidoo, D. (2008). Bernstein, Bloom and the analysis of pedagogy in South African schools. *Journal of Education*, 43, 31-56.

- Ibrahim, B., Buffler, A., & Lubben, F. (2009). Profiles of freshman physics students' views on the nature of science. *Journal of Research in Science Teaching*, 46(3), 248.
- Institute of Physics. (IOP) (2010). *The physics degree: Graduate skills base and the core of physics*. London: IOP Publishing. Retrieved from: <http://www.iop.org>.
- Institute of Physics (IOP). (2011). *The physics degree: Graduate skills base and the core of physics*. London: IOP Publishing. Retrieved from: <http://www.iop.org>.
- Institute of Physics (IOP) (2012). *The importance of physics to the UK economy*. London: IOP Publishing. Retrieved from: <http://www.iop.org>.
- Jacobs, C. (2005). On being an insider on the outside: New spaces for integrating academic literacies. *Teaching in Higher Education*, 10(4), 475-487.
- Jacobs, C. (2007a). Towards a critical understanding of the teaching of discipline-specific academic literacies: Making the tacit explicit. *Journal of Education*, 41, 59-81.
- Jacobs, C. (2007b). Mainstreaming academic literacy teaching: Implications for how academic development understands its work in higher education. *South African Journal of Higher Education*, 21(7), 870-881.
- Johannsen, B. F., Rump, C. Ø., & Linder, C. (2013). Penetrating a wall of introspection: A critical attrition analysis. *Cultural Studies of Science Education*, 8(1), 87-115.
- Johnson, D., & Johnson, R. (1984). *Circles of Learning*. Washington, DC: Association for Supervision and Curriculum Development.
- Johnson, D. W., & Johnson, R. T. (Eds.). (1991). *Learning mathematics and cooperative learning: Lesson plans for teachers*. Edina, MN: Interaction Books.
- Kilpert, L., & Shay, S. (2013). Kindling fires: Examining the potential for cumulative learning in a journalism curriculum. *Teaching in Higher Education*, 18(1), 40-52.
- Kloot, B., Case, J. M., & Marshall, D. (2008). A critical review of the educational philosophies underpinning Science and Engineering foundation programmes. *South African Journal of Higher Education*, 22(4), 799-816.
- Knight, R. D. (2007). *Physics for scientists and engineers: A strategic approach: With modern physics* (2<sup>nd</sup> ed.). San Francisco: Addison-Wesley Publisher.

- Kohl, P. B., & Finkelstein, N. D. (2006). Effects of representation on students solving physics problems: A fine-grained characterization. *Physical Review Special Topics: Physics Education Research*, 2, 010106.
- Kohl, P. B., & Finkelstein, N. D. (2008). Patterns of multiple representation use by experts and novices during physics problem solving. *Physical Review Special Topics: Physics Education Research*, 4, 010111.
- Kotecha, P., Allie, S., & J. Volmink. (1997). *Narset Report: Issues relating to Access and Retention in Science, Engineering and Technology in Higher Education*. Pretoria: Department of Arts, Culture, Science and Technology.
- Kotta, L. T. (2011). *Structural conditioning and mediation by student agency: A case study of success in chemical engineering design* (Unpublished doctoral thesis), University of Cape Town, South Africa.
- Larkin, J., McDermott, J., Simon, D. P., & Simon, H. (1980). Expert and novice performance in solving physics problems. *Science*, 208, 1335-1342.
- Lea, M. R., & Street, B. V. (1998). Student writing in higher education: An academic literacies approach. *Studies in Higher Education*, 23(2), 157-172.
- Leach, J., & Scott, P. (2003). Individual and sociocultural views on learning in science education. *Science & Education*, 12, 91-113.
- Lederman, N. G. (1992). Students' and teachers' conceptions of the nature of science: A review of the research. *Journal of Research in Science Teaching*, 29(4), 331-359.
- Lemke, J. L. (2001). Science and experience. In J. Wallece, & W. Louden (Eds.), *Dilemmas in science teaching: Perspectives on problems of practice* (pp. 22-36). London: Routledge/Falmer.
- Lemke, J. L. (2012). Multimedia and discourse analysis. In J. P. Gee & M. Handford (Eds.), *Routledge handbook of discourse analysis* (pp. 79-89). London: Routledge.
- Leonard, W. J., Dufresne, R. J., & Mestre, J. P. (1996). Using qualitative problem-solving strategies to highlight the role of conceptual knowledge in solving problems. *American Journal of Physics*, 64, 1495.
- Lesia, M., Marshall, D., & Schroeder, I. (2007). Making the tacit explicit: Accessing the discourse of physics. *For Engineering and Science Educators*, 11, 4-6.
- Lincoln, Y. S., & Guba, E. G. (1985). *Naturalistic inquiry*. Beverly Hills, CA:

Sage.

- Linder, A., Airey, J., Mayaba, N., & Webb, P. (2014). Fostering disciplinary literacy? South African physics lecturers' educational responses to their students' lack of representational competence. *African Journal of Research in Mathematics, Science and Technology Education, (AJRMSTE)*, 18 (3), 242-252.
- Linder, C. (1993). A challenge to conceptual change. *Science Education*, 77(3), 293-300.
- Linder, C., & Erickson, G. (1989). A study of tertiary physics students' conceptualization of sound. *International Journal of Science Education*, 11(5), 491-501.
- Linder, C., & Fraser, D. (2009). Higher Education and engineering: Generating interaction with the variation perspective on learning. *Education as Change*, 13(2), 277-291.
- Linder, C. J., & Hillhouse, G. (1996). Teaching by conceptual exploration: Insights into potential long-term learning outcomes. *The Physics Teacher*, 34(6), 332-338.
- Linder, C. J., Leonard-McIntyre, C., Marshall, D., & Nchodu, M. R. (1997). Physics tutors' metalearning development through an extension of Schön's reflective practice. *International Journal of Science Education*, 19(7), 821-833.
- Linder, C., & Marshall, D. (1998). Linking physics students' development as independent and reflective learners with changes in their conceptions of science. In C. Rust (Ed.), *Improving student learning: Improving students as learners* (pp. 107-117). Oxford: Oxford Centre for Staff and Learning Development.
- Lindstrøm, C. (2010). *Link maps and map meeting: A theoretical and experimental case for stronger scaffolding in first year university physics education* (Unpublished doctoral thesis), University of Sydney, Australia.
- Lindstrøm, C. (2010). Mapping the hierarchy: Advancing the theoretical and practical understanding of the hierarchical knowledge structure of physics. Paper presented at the *Sixth International Basil Bernstein Symposium*, Brisbane, Australia.
- Lindstrøm, C. (2012). Cumulative knowledge-building in a hierarchically knowledge structured discipline: teaching university physics to novices. Paper presented

- at the *Seventh International Basil Bernstein Symposium*, Aix-en Provence, France.
- Lindstrøm, C., & Sharma, M. (2009). Link maps and map meetings: Scaffolding student learning. *Physical Review Special Topics: Physics Education Research*, 5(1), 010102.
- Lindstrøm, C., & Sharma, M. (2011). Teaching physics novices at university: A case for stronger scaffolding. *Physical Review Special Topics: Physics Education Research*, 7(1), 1-14.
- Lubben, F. E. (2007). *Success through the General Entry Programme for Science (GEPS): Reflections by GEPS students in their third year at UCT*. Report to the Academic Development Programme, University of Cape Town.
- Luckett, K. M. (2010). A 'quality revolution' constrained? A critical reflection on quality assurance methodology from the South African Higher Education context. *Quality in Higher Education*, 16(1), 71-76.
- Macnaught, L., Matruglio, E., Maton, K., & Martin, J. R. (2013). Jointly constructing semantic waves: Implications for teacher training. *Linguistics and Education*, 24(1), 50-63.
- Marshall, D., & Case, J. (2010). Discourse in the learning of physics: The design of an introductory physics curriculum. *African Journal of Research in Mathematics, Science and Technology Education*, 14(2), 6-12.
- Marshall, D., Conana, H., Maclons, R., Herbert, M., & Volkwyn, T. (2011). Learning as accessing a disciplinary discourse: Integrating academic literacy into introductory physics through collaboration partnership. *Across the Disciplines*, 8(3).
- Marton, F., & Booth, S. (1997). *Learning and awareness*. Mahwah, NJ: Lawrence Erlbaum Associates.
- Marton, F., Hounsell, D., & Entwistle, N. (1997). *The experience of learning: Implications for teaching and studying in higher education*. Edinburgh, Scottish Academic Press.
- Marton, F., & Säljö, R. (1976). On qualitative differences in learning. I – Outcome and Process. *British Journal of Educational Psychology*, 46, 4-11.

- Maton, K. (2000). Language of legitimation: The structuring significance of intellectual fields of strategic knowledge claims. *British Journal of Sociology of Education*, 21(2), 147-167.
- Maton, K. (2006). On knowledge structures and knower structures. In R. Moore, M. Arnot, J. Beck, & H. Daniels (Eds.), *Knowledge, Power and Educational Reform* (pp. 44-59). London: Routledge.
- Maton, K. (2007). Knowledge-knower structures in intellectual and educational fields. In F. Christie, & J. R. Martin (Eds.). *Language, Knowledge and Pedagogy* (pp. 87-108). London: Continuum.
- Maton, K. (2008). Grammars of sociology: How to build knowledge. Paper presented at the *Fifth International Basil Bernstein Symposium*, University of Cardiff, United Kingdom.
- Maton, K. (2009). Cumulative and segmented learning: Exploring the role of curriculum structures in knowledge-building. *British Journal of Sociology of Education*, 30(1), 43-57.
- Maton, K. (2011). Theories and things: The semantics of disciplinarity. In F. Christie, & K. Maton (Eds.), *Disciplinarity: Functional linguistic and sociological perspectives*. London: Continuum.
- Maton, K. (2013). Making semantic waves: A key to cumulative knowledge-building. *Linguistics and Education*, 24(1), 8-22.
- Maton, K. (2014a). *Knowledge and knowers: Towards a realist sociology of education*. London: Routledge.
- Maton, K. (2014b). A TALL order? Legitimation Code Theory for academic language and learning. *Journal of Academic Language and Learning*, 8(3), 34-48.
- Maton, K. (2014c). Building powerful knowledge: The significance of semantic waves. In B. Barrett, & E. Rata (Eds.), *Knowledge and the future of curriculum: International studies in social realism* (pp. 181-197). London: Palgrave Macmillan.
- Maxwell, J. A. (1998). Designing a qualitative study. In L. Bickman, & D. J. Rog (Eds.), *Handbook of applied social science research methods* (pp. 1-22). Thousand Oaks, CA: Sage.
- Mazur, E. (1997). *Peer instruction: A user's manual. Series in educational innovation*. Upper Saddle River, NJ: Prentice Hall.

- Mazur, E. (2007). *Interactive teaching: Promoting better learning using peer instruction and just-in time teaching*. Cambridge, MA: The Derek Bok Center for Teaching and Learning, Harvard University in Association with Spectrum Media and Pearson Education.
- Mazur, E. (2009). Farewell, lecture? *Science*, 323, 50-51.
- McDermott, L. C. (1984). Research on conceptual understanding in mechanics, *Physics Today*, 37, 24-32.
- McDermott, L. C., Rosenquist, M. L., & Van Zee, E. H. (1987). Student difficulties in connecting graphs and physics: Examples from kinematics. *American Journal of Physics*, 55, 505-513.
- McKenna, S. (2004). *A critical investigation into the discourses used to construct Academic Literacy at the Durban Institute of Technology* (Unpublished doctoral thesis), Rhodes University, South Africa.
- McKenna, S. (2010). Cracking the code of academic literacy: An ideological task. In C. Hutchings & J. Garraway (Eds.), *Beyond the university gates: Provision of extended curriculum programmes in South Africa* (pp. 11-28). HELTASA.
- McNamara, M. S., & Fealy, G. M. (2011). Editorial: Legitimation Code Theory: A new lens through which to view our academic practice. *Contemporary Nurse*, 38(1-2), 119-121.
- Mehl, M. (1988). Academic Support: Developmental Giant or Academic Pauper. *South African Journal of Higher Education*, 2(1), 17-20.
- Merriam, S. B. (1988). *Case study research in education: A qualitative approach*. San Francisco: Jossey-Bass.
- Miles, M. B., & Huberman, A. M. (1994). *An Expanded Sourcebook* (2<sup>nd</sup> ed.). *Qualitative Data Analysis*. London, New Delhi: Sage Publications.
- Moore, R., & Maton, K. (2001). Founding the sociology of knowledge: Basil Bernstein, intellectual fields and the epistemic device. In A. Morais, I. Neves, B. Davies & H. Daniels (Eds.), *Towards a sociology of pedagogy* (pp. 153-182). New York: Peter Lang.
- Morais, A. M., & Neves, I. P. (2011). Educational texts and contexts that work: Discussing the optimization of a model of pedagogic practice. In D. Frandji, & P. Vitale (Eds.), *Knowledge, pedagogy & society: International perspectives on Basil Bernstein's sociology of education*. London: Routledge.



- Morrow, W. (1993). Epistemological access in the university. *AD Issues*, 1(1), 3-4.
- Mortimer, E. F., & Scott, P. H. (2003). *Meaning making in secondary science classroom*. Buckingham, UK: Open University Press.
- Muller, J. (2007). On splitting hairs: Hierarchy, knowledge and the school curriculum. In F. Christie & J. R. Martin (Eds.), *Language, knowledge and pedagogy: Functional linguistic and sociological perspectives*. London: Continuum.
- Nguyen, N., & Meltzer, D. (2003). Initial understanding of vector concepts among students in introductory physics courses. *American Journal of Physics*, 71(6), 628-638.
- Niemann, R., Niemann, S., Brazelle, R., Van Staden, J., Heyns, M., & De Wet, C. (2000). Objectivity, reliability and validity in qualitative research. *South African Journal of Education*, 20(4), 283-286.
- Northedge, A. (2003). Rethinking teaching in the context of diversity. *Teaching in Higher Education*, 8(1), 17-32.
- Paxton, M., & Frith, V. (2014). Implications of academic literacies research for knowledge making and curriculum design. *Higher Education*, 67(2), 171-182.
- Pinto, D. (Ed.) (2001). *Directory of science, engineering and technology foundation programmes*. Johannesburg: University of Witwatersrand, Central Printing Unit.
- Podolefsky, N.S., & Finkelstein, N.D. (2007). Analogical scaffolding and the learning of abstract ideas in physics: Empirical studies. *Physics Review Special Topics: Physics Education Research*, 3(2), 020104.
- Posner, G. J., Strike, K. A., Hewson, P. W., & Gertzog, W. A. (1982). Accommodation of a scientific conception: Towards a theory of conceptual change. *Science Education*, 66, 211-227.
- Quality Assurance Agency for Higher Education (QAA). (2002). *Handbook for the Review of Foundation Degrees: I-England 2002-03*. The Quality Assurance Agency for Higher Education.
- Redish, E. F. (1994). Implications of cognitive studies for teaching physics. *American Journal of Physics*, 62(9), 796-803.
- Rollnick, M. (1998). Relevance in science and technology education. In P. Naidoo & M. Savage (Eds.), *African science and technology education into the new millennium: Practice, policy and priorities* (pp. 79-90). Cape Town: Juta.

- Rollnick, M. (2010). *Identifying potential for equitable access to tertiary level science: Digging for gold*. Dordrecht: Springer.
- Rosengrant, D., Van Heuvelen, A., & Etkina, E. (2009). Do students use and understand free-body diagrams? *Physical Review Special Topics: Physics Education Research*, 5, 010108.
- Scott, I., Yeld, N., & Hendry, J. (2007). A case for improving teaching and learning in South African higher education. *Higher Education Monitor Series*, Pretoria: Council on Higher Education.
- Shaffer, P. S., & McDermott, L. C. (1992). Research as a guide for curriculum development: An example from introductory electricity. Part II: Design of instructional strategies. *American Journal of Physics*, 60(11), 1003-1013.
- Sharma, M. D., Mills, D., Mendez, A., & Pollard, J. (2005). *Learning outcomes and curriculum development in physics*. A report commissioned by the Australian Universities Teaching Committee and the Carrick Institute for Learning and Teaching in Higher Education.
- Shay, S., & Steyn, D. (2015). Enabling knowledge progression in vocational curricula: Design as a case study. In K. Maton, S. Hood, & S. Shay (Eds.), *Knowledge-building: Educational studies in Legitimation Code Theory*. London: Routledge.
- Shulman, L. S. (1986). Those who understand: Knowledge growth in teaching. *Educational Researcher*, 15, 4-14.
- Singer, S., Nielsen, N., & Schweingruber, H. (2012). *Discipline-based education research: Understanding and improving learning in undergraduate science and engineering*. Washington D.C.: National Academies Press.
- Smith, L., Case, J., & Van Walbeek, C. (2014). Assessing the effectiveness of academic development programmes: A statistical analysis of graduation rates across three programmes. *South African Journal for Higher Education*, 28(2), 624-638.
- Sokoloff, D., & Thornton, R. (1997). Using interactive lecture demonstrations to create an active learning environment. *The Physics Teacher*, 35, 340-346.
- South African Institute of Physics (SAIP) (2004). *Shaping the future of physics in South Africa*.

- Street, B. (2009). 'Hidden' features of academic paper writing. *Working Papers in Educational Linguistics*, 24(1), 1-17.
- Tang, K. S., & Moje, E. (2010). Relating multimodal representations to the literacies of science. *Research in Science Education*, 40, 81-85.
- Tang, K. S., Tan, S. C., & Yeo, J. (2011). Students' multimodal construction of the work-energy concept. *International Journal of Science Education*, 33(13), 1775-804.
- Trigwell, K., & Shale, S. (2004). Student learning and the scholarship of university teaching. *Studies in Higher Education*, 29(4), 523-536.
- Van Heuvelen, A. (1991a). Learning to think like a physicist: A review of research-based instructional strategies. *American Journal of Physics*, 59(10), 891-897.
- Van Heuvelen, A. (1991b). Overview: Case study physics. *American Journal of Physics*, 59, 898-907.
- Van Heuvelen A., & Zou, X. (2001). Multiple representations of work-energy processes. *American Journal of Physics*, 69(2), 184-194.
- Volbrecht, T., & Boughey, C. (2004). Curriculum responsiveness from the margins? A reappraisal of academic development in South Africa. In H. Griesel (Ed.), *Curriculum Responsiveness: Case Studies in Higher Education*. Pretoria: SAUVCA.
- Walker, M., & Badsha, N. (1993). Academic development and the challenge of curriculum change at the University of the Western Cape: An overview. In M. Walker (Ed.), *AD Dialogues 1 – Exploring change: Case studies of academic development*. University of the Western Cape.
- White, R., & Gunstone, R. (1992). *Probing understanding*. London and New York: The Falmer Press.
- Wieman, C. E., & Perkins, K. K. (2005). Transforming education. *Physics Today*, 58(11), 36.
- Zulkardi, W. G. (2009). Case study research: Triangulation in educational research, design and methods. Retrieved from: <http://geocities.com/zulkardi/submit3.html>.

## Appendices

### 1. Curriculum Documents

#### Appendix 1A – Mainstream information sheet

#### PHYSICS 111 MODULE – 2012 INFORMATION SHEET AND SCHEDULE

**PRESCRIBED BOOKS:** PHYSICS FOR SCIENTISTS AND ENGINEERS – A STRATEGIC APPROACH by Knight. This book may be leased from the University (Foyer in Main Library) for R200.00. A maximum of R100 will be refunded when the book is returned at the end of the year.

**TUTORIALS:** Tutorial sessions will be held on Tuesdays at 12:00. For the tutorials you require a student workbook, which is obtainable from the secretary's office for R50. Please consult the notice boards on the ground floor of the Physics building for further information.

**EVALUATION:** Carefully read regulations on the relevant pages in the UWC General Calendar:

1. A final mark of 50% is required to pass this module.
2. The practical work for this semester is incorporated into, and will be evaluated as part of this module.
3. The **FINAL MARK** for the module will be made up as follows:

| ASSIGNMENTS & TASKS | PRACTICALS | TESTS | FINAL TEST |
|---------------------|------------|-------|------------|
| 15%                 | 15%        | 30%   | 40%        |

4. The re-evaluation only covers the theory part of the course content.
5. The mark obtained in the re-evaluation only replaces the test marks.

The following departmental rules need to be carefully read, as no exceptions will be made:

- Correction of tests will be done within 5 (five) academic days of writing the test. Once your marks have been placed on the notice boards, you have 5 (five) academic days within which to submit a query. No late adjustments will be made.
- Tests will be returned in class and/or during the tutorial session. Should you miss that class or tutorial session, the scripts will be placed in a box outside your lecturer's office. The Physics Department will not accept any responsibility for these scripts.



| TERM1<br>Week # | Week<br>Starting | No. of<br>Lectures | Chapters in KNIGHT  | Mark<br>(Time)       |
|-----------------|------------------|--------------------|---|----------------------|
| 1               | 30 Jan           | 3                  | Chapter 1: Concepts of Motion   |                      |
| 2               | 06 Feb           | 3                  | Chapter 1 cont<br>Chapter 2: Kinematics in One Dimension  |                      |
| 3               | 13 Feb           | 3                  | Chapter 2 cont<br>Chapter 3: Vectors and coordinate systems   |                      |
| 4               | 20 Feb           | 3                  | Chapter 4: Kinematics in Two Dimensions<br><b>Test 1 on Tues 21 Feb @ 12:00</b><br>Chapter 5: Forces and Motion | 30 marks<br>(50 min) |
| 5               | 27 Feb           | 3                  | Chapter 5 cont<br>Chapter 6: Dynamics I: Motion along a straight Line   |                      |
| 6               | 05 March         | 3                  | Chapter 6 cont<br>Chapter 7: Newton's Third Law   |                      |
| 7               | 12 March         | 3                  | Chapter 7: Cont<br>Chapter 8: Dynamics II: Motion in a Plane<br><b>Test 2 on Mon 12 March @ 17:30</b>           | 50 marks<br>(90 min) |

#### TERM2

|    |          |   |  |                      |
|----|----------|---|--|----------------------|
| 1  | 26 March | 3 | Chapter 9: Impulse and Momentum  |                      |
| 2  | 02 April | 2 | Chapter 9 cont<br>Fri 6 April: Good Friday   |                      |
| 3  | 09 April | 2 | Chapter 10: Energy<br>Mon 9 April: Family Day<br><b>Test 3 on Tue 12 April @ 12:00</b> | 30 marks<br>(50 min) |
| 4  | 16 April | 3 | Chapter 10 cont  |                      |
| 5  | 23 April | 2 | Chapter 11: Work<br>Fri 27 April: Freedom Day  |                      |
| 6  | 30 April | 3 | Chapter 11 cont<br>Chapter 12: Rotation of a Rigid Body<br>Tues 1 May: Workers Day     |                      |
| 7  | 7 May    | 3 | Chapter 12 cont<br>Chapter 13: Newton's Theory of Gravity                              |                      |
| 8  | 14 May   | 3 | Chapter 13 cont<br><b>Test 4 on Mon 7 May @ 17:30</b>                                  | 50 marks<br>(90 min) |
| 9  | 21 May   | 0 | Wed 23 May: Final Assessment Commences   |                      |
| 10 | 28 May   | 0 | Final Assessment (cont)  |                      |
| 11 | 04 June  | 0 | Final Assessment (cont)  |                      |
| 12 | 11 June  | 0 | Wed 13 June: Suppl and re-evaluation   |                      |
| 13 | 18 June  | 0 | Suppl and re-evaluation (cont)   |                      |

## Appendix 1B – Extended course reader

### EXTENDED CURRICULUM PROGRAMME (ECP) PHYSICS 151: COURSE INFORMATION 2012

#### Introduction

All the information about the PHY151 course is fully described in this reader. You should read the contents thoroughly and become aware of what will be required of you to succeed in this course. The group lecturers will assist you in your learning, but you should become aware of your role and responsibility in your learning. The course purposes to give you access to learning the sciences in higher education (University), particularly to prepare you for higher-level studies in physics. It is expected that you will bring this reader to *all* classes.

#### Contents

|   | page no. |
|---|----------|
| Foreword by the ECP PHY151 lecturers                                      | 3        |
| Information about ECP PHY151 teaching staff                               | 3        |
| Class venue and time tables for groups 1 and 2                            | 3        |
| General information about the course                                      | 4        |
| PHY151 course philosophy  | 4        |
| PHY151 teaching methods   | 4        |
| PHY151 learning goals   | 4        |
| PHY151 course description and topics covered                              | 5        |
| Laboratory component  | 6        |
| Utilising skills developed in the Introduction to Science module (ISC153) | 7        |
| PHY151 course assessment  | 7        |
| Feedback in PHY151  | 9        |
| Policy on late assignments  | 10       |
| Academic integrity  | 10       |
| Course material and textbooks   | 10       |
| Stationary requirements   | 10       |
| <b>Foreword by the ECP PHY151 group lecturers and teaching assistant</b>  |          |

The PHY151 lecturers base their teaching on current international best practice in tertiary education and physics education. You are one of the few privileged South Africans that have been afforded the opportunity to study at university. We therefore expect from you full cooperation and effort to develop your full potential and to lay a good foundation for further study in the sciences.

.....

.....

Most class work will be interactive, so there will be ample opportunity for you to ask questions during class time. However, you may have specific difficulties with the work which you would like to discuss with your lecturers and/or teaching assistants. Times will be announced when you can consult the lecturers and teaching assistants. If times don't suit you arrange an alternative time when you can consult them.

Feel free to contribute any suggestions to make your experience in PHY151 during 2012 a very worthwhile and memorable one.

### **Class venue**

ALL class activities, including laboratory tasks will be take place in room 1.48, also called the "High Tech Lab", except for the Tuesday tutorial session for group 2 which takes place in room 1.40. Refer to your timetable for your class group for the times and venues (summarised below).

### **General information about the course**

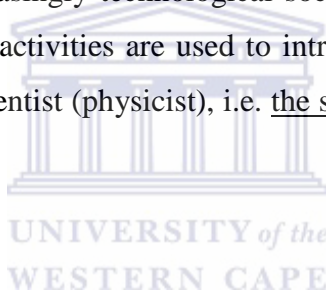
The physics component of the Extended Curriculum Programme (ECP) is split into two full year courses. Physics 151 (PHY151) is the first year course and counts 15 credits towards your degree. If you pass PHY151 you can continue with Physics 152 (PHY152), which also counts 15 credits. Hopefully after two years in ECP Physics, some of you may want to continue with Physics and may then enroll for second year Physics courses. It is important to note that the course content of the Extended Curriculum Programme (ECP) Physics course is similar to that of the mainstream Physics course, i.e. taken by students in the three-year degree programme. The main differences between the two courses are mainly in the delivery rate of the course content, teaching methods used, and additional course provisions, which are designed



to assist you in bridging the gap between school and university. Therefore, like the mainstream Physics course, the ECP Physics course provides a foundation for further study in physics, i.e. you can take physics as major subject.

### **PHY151 course philosophy**

The course is designed around a few basic principles and approaches. These have been adopted by studying international best practice in tertiary education and keeping abreast of Physics Education trends. Central to our course philosophy is that our course is delivered in such a way as to facilitate the learning process of our students. The course places at its centre the notion that students need to be exposed explicitly to all the aspects of what it means to be a scientist (physicist). The focus is not on what students don't know, but what is required to develop into successful practitioners of science (physics). In a broader context, the course will prepare students to function as informed citizens in an increasingly technological society and world. In this course classes, laboratory and other activities are used to introduce students to the ways of thinking and working as a scientist (physicist), i.e. the student is seen as a physicist in training.



### **PHY151 teaching methods**

A group of lecturers and a teaching assistant will facilitate the learning of the students – together with tutors for certain activities. Classes are given in a flat space venue and students are expected to interact and engage with the content. Carefully designed pre-class “warm-up” tasks and exercises are given to students before each class as preparation. This work will be assessed regularly and will count towards your class record. Class time is spent mostly in small group discussions on the pre-class “warm-up” tasks and exercises. Extensive and immediate feedback is aimed for at all times so that students can monitor their progress learning. The main idea is that the style of delivery of course content is to facilitate student learning.

## PHY151 learning goals

- understand the nature of science, particularly in a physics context.
- relevance of science, especially physics in our everyday life and the real world.
- understanding of the process by which we make sense of physical phenomena:
  - to build an understanding of the *fundamental principles* underlying *physical phenomena*,
  - to develop the ability to *describe* these phenomena *verbally* and *mathematically*,
  - to develop *analytical skills* applicable to a wide range of situations both within and outside physics,
  - to provide a *foundation* for further study in physics (or other science courses).
  - to develop a sound and deeper *understanding of measurement* in science

## PHY151 course description and topics covered

### Theory component



### Semester 1

In the first semester, Hewitt's *Conceptual Physics* forms the backbone of the content covered. Students are taught to solve problems conceptually and express their reasoning verbally and in written work. The idea is that students are learning to practice as scientists. It is highly recommended that each student obtain his or her *own* personal copy of the prescribed textbook.

#### *Week 1: Course Introduction*

This week will be used to familiarise students with what is expected of both the teaching staff and students.

#### *Week 2-3: The nature of science*

How physics knowledge is constructed, structured, applied and used in the real world and communicated. Emphasis is placed on the Scientific Method, which underlies the delivery of the rest of the content of the course. Students are shown explicitly how this method underlies theory testing and construction as well as experimental and

investigative activities. How scientific (physics) knowledge is structured and constructed takes centre stage.

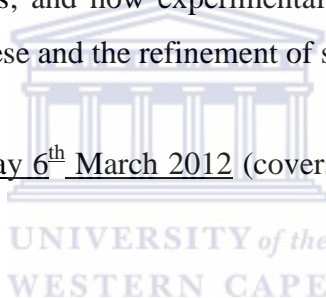
*Week 4: Atomic nature of matter*

Discuss matter in terms of its building blocks and phases and how this information is arranged in the periodic table. Students are again required to solve problems conceptually and express their reasoning clearly in written work. Particular emphasis is placed here on the structure of scientific knowledge.

*Week 5 – 7: Development of models that describe the atom*

Model construction and structure and how they have shaped our modern view of the building blocks of matter are addressed. The models explain the arrangement of the elements in the periodic table. Particular emphasis is placed on the development of scientific models and theories; and how experimental results have and can directly inform the development of these and the refinement of scientific knowledge.

*Week 7: Term test 1 – Tuesday 6<sup>th</sup> March 2012* (covers all term 1 work up to Fri 2<sup>nd</sup> March 2012)



*Week 8 – 10: The Atomic Nucleus and Radioactivity*

The discovery and explanation of radioactivity in terms of the conceptual understanding and consequences with regard to the atomic model of matter; the natural and artificial transmutation of elements. The role of accidental discovery in the development of science and how the collegiate practice of scientists can lead to new knowledge is emphasized. The social context aspects are dealt with in terms of the influence of radioactivity on our everyday lives and its uses in the form of technology – its advantages and disadvantages.

*Week 11 – 12: Fission and fusion*

The discovery of fission and fusion; the impact of these natural and man-made processes on our daily lives – harnessing of energy resources and its potential for mass destruction, the influence on global political issues.

*Week 13 – 15: Kinematics Part I: Describing motion*

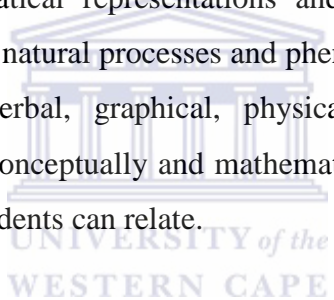
Emphasis is placed on the modelling of motion and the concepts used to describe it. The Van Heuvelen approach and the techniques employed by Knight form the basis of using the different representations (verbal, pictorial, graphical) to describe linear one-dimensional motion and rotational motion, and solve problems.

*Week 14: Term test 2: Tuesday 8<sup>th</sup> May 2012 (covers all term 2 work up to Fri 4<sup>th</sup> May 2012)*

*Semester 1 Test and project: details to follow ...*

**Semester 2**

The emphasis in the 2<sup>nd</sup> semester shifts to the development of problem-solving techniques and the mathematical representations and skills that are required to complete a full description of natural processes and phenomena in physics. Modelling problem-solving strategy (verbal, graphical, physical, mathematical, solve and evaluate) to solve problems conceptually and mathematically. Problems are posed in relevant contexts to which students can relate.



*Week 1 – 4: Kinematics Part II: The full description of motion in 1- and 2-dimensions*

The methods and techniques of problem solving are explicitly taught to students. The modelling aspects of problem solving are presented. The mathematical description of models, in this case linear motion in one and two dimensions, is introduced as a part of the bigger modelling process. Students are guided in developing their analytical skills by learning to apply and use the linear equations of motion to solve problems together with using the other representations. Vectors and the use of unit vector notation will be introduced.

*Week 5 – 8: Dynamics: Applying Newton's law of motion to problems in relevant contexts to which students can relate in 1- and 2- dimensions*

Discuss what a force is and its nature (different type of forces) and how we model (verbal and graphical) forces in physics. Conceptual understanding of Newton's laws

of motion – the causes of motion; the application of Newton’s Laws. Using vectors to analyse force problems.

*Week 6: Term test 3: Tuesday 21<sup>th</sup> Aug 2012* (covers all term 3 work up to Fri 17<sup>th</sup> Aug 2012)

*Week 9 – 12: Conservations laws (Momentum and Energy) and the Work-Energy Theorem*

Conceptual understanding of what momentum is and how it relates to Newton’s laws of motion. Applying the law of conservation of momentum to problems. Again the use of vector algebra will be foregrounded.

Conceptual understanding of what energy is and its nature (different types of energy) and how it relates to work. Conceptual understanding of what the Work-Energy Theorem is. Introduction to vector multiplication, i.e. the dot or scalar product.

Conceptual understanding of what is meant by conservation of energy, e.g. conservation of mechanical energy. Applying the law of conservation of energy to problems.

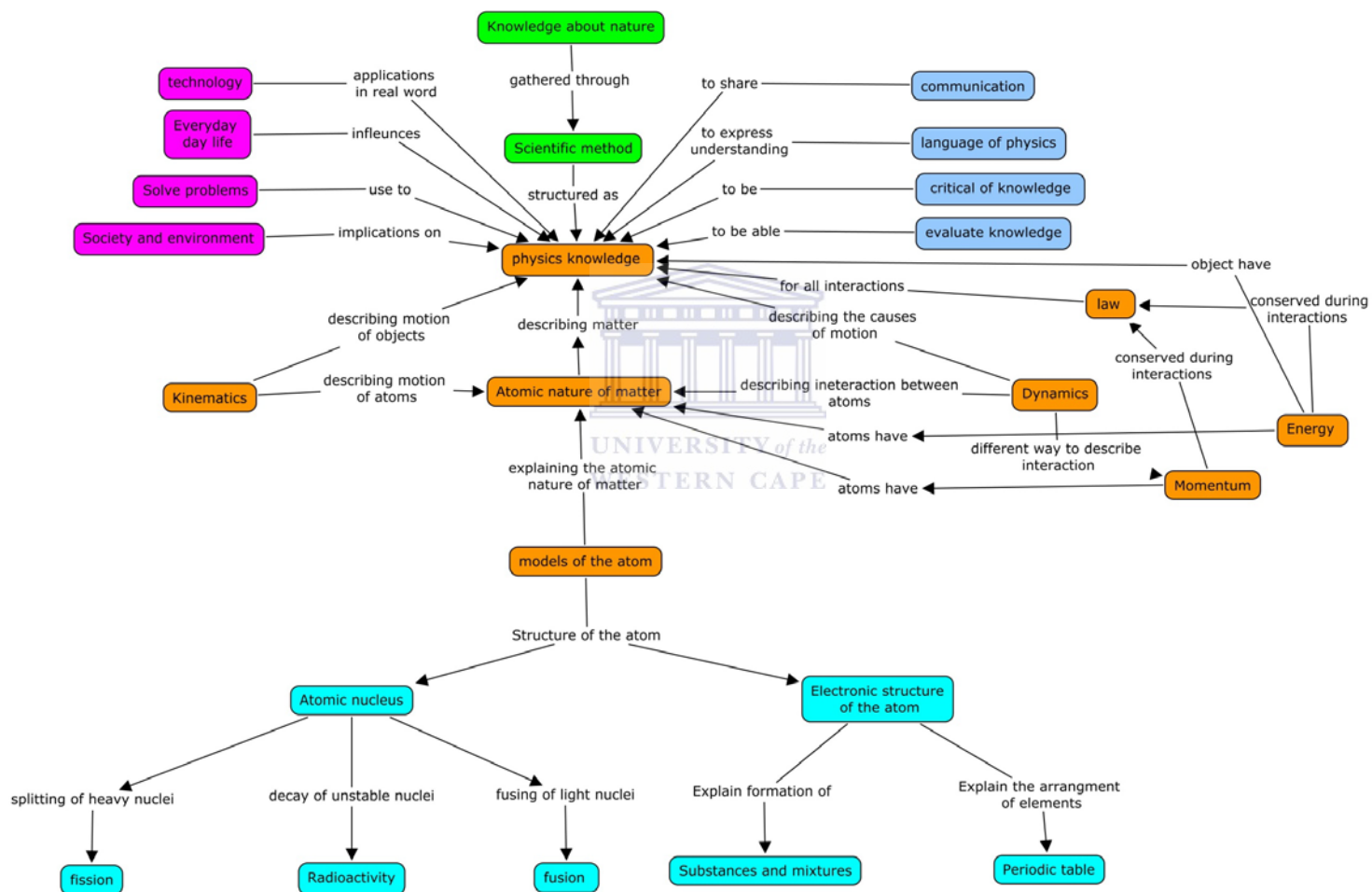
*Weeks 13 – 14: Rotational Dynamics*

Introduction to rotational dynamics and the vector or cross product of vectors.

*Week 13: Term test 4: Tuesday 16<sup>th</sup> Oct 2012* (covers all term 4 work up to Fri 12<sup>th</sup> Oct 2012)

*Final Examination: details to follow ...*

## Appendix 1C – Extended course Concept map



## 2. Summary data of pedagogical practices – lecture sequence 2

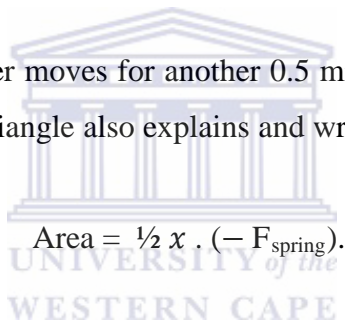
### Appendix 2A – Mainstream course

Part 1: Lecturer starts at **L** for 4 minutes (from 0 to 4 minutes)

- This part is coded as **Linking** level because the lecturer recaps from the previous lecture ( $W_f = \vec{F} \cdot \vec{s}$ ). He draws the sketch of a spring reminds the students about how the restoring force varies when compressed and stretched. He uses the formula ( $W_f = \vec{F} \cdot \vec{s}$ ) to explain the sketch.

Part 2: Lecturer moves from **L** → **A** → **L** for 1 minute (from 4 to 5 minutes)

- Sub-part 2a: For 0.5 minutes the lecturer moves from the Linking level to the **Abstract** level. He draws a graph of  $F_{\text{spring}}$  vs  $x$  and relates the concept of work done by a spring to the area under the graph.
- Sub-part 2b: Then the lecturer moves for another 0.5 minutes to the **Linking** level to unpack the graph into the area of a triangle also explains and writes on the board the formula in terms of the area


$$\text{Area} = \frac{1}{2} x \cdot (-F_{\text{spring}}).$$

Part 3: Lecturer moves from **L** → **A** → **L** → **C** for 3 minutes (from 5 to 8 minutes)

- Sub-part 3a: For 1 minute the lecturer moves from the Linking level to the **Abstract** level to relate the area under the graph to the concept of work done, and then writes it on the board as:

$$W_{\text{spring}} = \frac{1}{2} x \cdot (-kx) = -\frac{1}{2} kx^2$$

- Sub-part 3b: The lecturer then moves back to the **Linking** level for 1 minute to use the sketch and explain the negative sign above.
- Sub-part 3c: Again for another minute the lecturer moves to the **Concrete** level to explain and demonstrate with his hands to show what will happen if the spring is being stretched or compressed in relation to the formula above.

Part 4: Lecturer moves from **C** → **A** for 5 minutes (from 8 to 13 minutes)

- The lecturer then moves from the **Concrete** level to the **Abstract** level by noting that he will do this more mathematically. He then uses the graph, breaking the triangle into smaller areas to show the principle of integration in mathematics. He explains this and writes the formula on the board:

$$\begin{aligned}
 W &= F_1 \Delta x + F_2 \Delta x \\
 \therefore W &= \sum F_1 \Delta x \\
 W_{\text{spring}} &= \int_{\Delta x = 0}^x F_1 \Delta x \\
 &= \int_0^x F dx
 \end{aligned}$$

Part 5: Lecturer moves from **A** → **L** for 1 minute (from 13 to 14 minutes)

- The lecturer then moves from the **Abstract** level to the **Linking** level to unpack the integral sign – here, he explains the meaning of the sign as taking into account the sum of various areas and uses the graph to show where the integral starts and ends.

Part 6: Lecturer moves from **L** → **A** for 2 minutes (from 14 to 16 minutes)

- The lecturer then moves from the **Linking** level to the **Abstract** level and relates the graph to the integral:

$$\begin{aligned}
 W_{\text{spring}} &= \int_0^x (-kx) dx \\
 &= -k \int_0^x x dx \\
 &= -kx^2/2 \\
 &= -\frac{1}{2} kx^2
 \end{aligned}$$

Part 7: Lecturer and students start at **C** → **L** → **A** for 4 minutes (from 16 to 20 minutes)

- Sub-part 7a: For 1 minute, the lecturer introduces the new concept of ‘power’ through a demonstration – he lifts a book from the floor, first fast and then slowly, and notes that he does the same work on the book, even though the time taken to lift the book is different. This is coded as **Concrete** level.
- Sub-part 7b: Then for another minute, the lecturer defines the concept of power and writes the definition on the board: Power – rate of doing work. Then, he links the meaning of the



concept of Power to isiXhosa; he says ‘it is not the black power in isiXhosa, we use the English terms but with different meaning’. This is coded as **Linking** level.

- Sub-part 7c: Then for 2 minutes, the lecturer asks the students, ‘what symbol do we use for Power?’, then a student answers – ‘Watts’. He then says ‘no, not the unit but the symbol’. Then, the whole class respond – ‘P’. He then explains that the symbol P is a capital letter and is different from the small letter p for the concept of Momentum. He writes the formula of Power in words and then in symbolic form on the board: This is coded as **Abstract** level.

$$\text{Power} = \frac{\text{work done}}{\text{time taken}} ; P = \frac{\Delta W}{\Delta t}$$

$$\text{then, the units of Power } [P] \equiv \frac{[W]}{[t]} \equiv \frac{J}{s} \equiv J.s^{-1} \equiv \text{Watts (W)}$$

Part 8: Lecturer and students move from **A** → **L** → **A** for 14 minutes (from 20 to 34 minutes)

- Sub-part 8a: For 2 minutes the lecturer says, ‘let’s think of an example’, and then he gives a verbal example of a car which is moving up the hill. This is coded as **Linking** level.
- He draws a sketch on the board, labels the angle of incline as  $\theta = 37^\circ$ , and indicates on the sketch the significant information about the car as he says: ‘let’s say the car is moving at 10m/s at the bottom of the hill and 30m/s at the top and it takes 30s from bottom to top; the distance is 200m, and let’s say friction acts,  $\mu_k = 0,2$  and the mass is 500kg. He then says, ‘the question is, what is the Power?’
- Sub-part 8b: This sub-part is coded as **Abstract** level since the application of the concept of Power is new to the students. For 12 minutes the lecturer asks the students to solve the problem. While students were busy with the problem, he guides them through on how to solve it. He identifies the significant forces: ‘the most obvious one is the gravitational force, then there would be the normal reaction, then we would also have friction’. He then draws a FBD on the sketch and draws.  $F_N$ ;  $f_k$ ; and 5000N (he says ‘mass multiple by 10). Then he writes on the board:

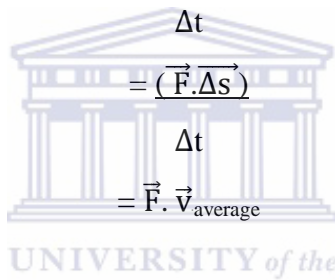
$$\text{up: } F_{\text{net}} = F - f_k - 5000N \sin 37^\circ ; \quad F = 500 \cdot a ; \quad f_k = \mu_k F_N ;$$

He allows students to solve the problem, and then, he says, ‘work it out in terms of work-energy, then he guides them and writes on the board:

$$\begin{aligned} \text{i.e. } W_{\text{Fres}} &= \vec{F}_{\text{res}} \cdot \vec{S} \\ &= (F - fk - 5000\text{N} \sin 37^\circ) s = \frac{1}{2} \cdot 500 (30^2 - 10^2) \end{aligned}$$

He left the problem incomplete and then, he says, ‘I want you to do this on your own’.

He then says, ‘I’m going to do the same calculation in a nice way’. Then, he writes the formula on the board and guides students on how to solve the problem.

$$\begin{aligned} P &= \frac{\Delta W}{\Delta t} \\ &= \frac{\Delta(\vec{F} \cdot \vec{S})}{\Delta t} \\ &= \frac{(\vec{F} \cdot \Delta \vec{S})}{\Delta t} \\ &= \vec{F} \cdot \vec{v}_{\text{average}} \end{aligned}$$


Part 9: Lecturer and students start at **L** → **C** for 2 minutes (from 34 to 36minutes)

- Sub-part 9a: For 1 minute the lecturer introduces another concept – he says ‘now we come to another process, which is called energy’ then he asks the students, ‘what is energy’? The students answer ‘the ability to do work’ and he writes their response on the board in a context of physics: Energy – ability a body possesses to do work. This is coded as **Linking** level.
- Sub-part 9b: This sub-part is coded as **Concrete** level. For another minute the lecturer then gives a verbal example, ‘if you drop something (object) on top of your feet, what will happen to you’? Then he explains the demonstrates in terms of energy.

Part 10: Lecturer moves from **C** → **L** → **A** for 6 minutes (from 36 to 42 minutes)

- Sub-part 10a is coded as **Linking** level. For 2 minutes the lecturer draws a sketch to show where the object is, in terms of gravitational potential energy (U):

$$U = mgh \qquad \text{top: } U_i = mgh \qquad \text{bottom: } U_f = 0$$

- Sub-part 10b is coded as **Abstract** level. For 4 minutes the lecturer uses the sketch to explain the formula [i.e. work done by gravitational force in terms of the change in gravitational potential energy (U)]:

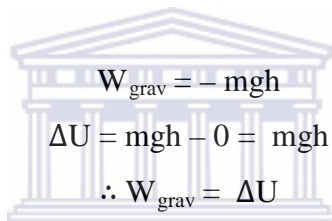
$$W_{\text{Fres}} = \vec{F}_{\text{res}} \cdot \vec{s} = mgh$$

$$\Delta U = U_f - U_i = 0 - mgh = -mgh$$

$$\therefore W_{\text{Fres}} = W_{\text{grav}} = -\Delta U$$

Part 11: Lecturer moves from **A** → **C** → **L** → **A** for 2 minutes (from 42 to 44 minutes)

- Sub-part 11a is coded as **Concrete** level. For 0.5 minutes the lecturer throws something up to demonstrate a body that is going vertically upwards.
- Sub-part 11b is coded as **Linking** level. For 0.5 minutes the lecturer then draws a sketch.
- Sub-part 11c is coded as **Abstract** level. For 1 minute the lecturer writes the formula to explain that:



$$W_{\text{grav}} = -mgh$$

$$\Delta U = mgh - 0 = mgh$$

$$\therefore W_{\text{grav}} = \Delta U$$

He then says ‘this is the first form of energy; let’s look at another one, kinetic energy’.

Part 12: Lecturer moves from **A** → **L** → **A** for 4 minutes (from 44 to 48 minutes)

- Sub-part 12a is coded as **Linking** level. For 2 minutes the lecturer gives a verbal example, then draws a sketch, uses this sketch to derive a mathematical expression of kinetic energy and writes that on the board:

$$\text{Kinetic energy: } K = \frac{1}{2} mv^2$$

- Sub-part 12b is coded as **Abstract** level. For 2 minutes the lecturer then asks, ‘how is this related to work’? Then he answers and writes on the board:

$$\text{Recall: } W_{\text{net}} = \frac{1}{2} mv_f^2 - \frac{1}{2} mv_i^2$$

$$= K_f - K_i$$

$$W_{\text{total}} = W_{\text{net}} = \Delta K$$

Work-Energy Theorem

Part 13: Lecturer starts at **L** → **A** for 4 minutes (from 48 to 52 minutes)

- Sub-part 13a is coded as **Linking** level. For 1 minute the lecturer says ‘the last example’, then he gives a verbal example and draws a sketch of an object that is falling from a height of 1,5 m, and he asks a question – what is the final velocity  $v$ ?
- Sub-part 13b is coded as **Abstract** level. For 3 minutes the lecturer says, ‘of course you have to use kinematics; what is given is:  $s = 1,5\text{m}$ ;  $v_0 = 0$ ;  $a = 10\text{m.s}^2$ ;  $v_f = ?$ ; remember you have to choose direction, and he insisted ‘you have to’. Then he writes the solution on the board:

$$\text{Using } [v_f^2 = v_0^2 + 2a(s - s_0)]$$

$$v^2 = 0 + 2 \cdot 10 (1,5 - 0)$$

$$\therefore v = \dots$$

- Then he lets the students find the final answer.
- Then he introduces a new way of solving the problem as he says, ‘let us now use the Work-Energy Theorem to find the solution’. He writes on the board:

$$\text{W.E theorem: } W_{\text{res}} = \Delta K$$

Part 14: Lecturer moves from **A** → **L** → **A** for 3 minutes (from 52 to 55 minutes)

- Sub-part 14a is coded as **Linking** level. For 1 minute the lecturer recaps from Work- Energy Theorem for a falling object and writes the formula on the board:

$$W_{\text{res}} = \Delta K$$

- Sub-part 14b is coded as **Abstract** level. For 2 minutes the lecturer relates the work done by gravitational force to change in energy as he says, ‘the only force is  $F_{\text{grav}}$ ’ and writes on the board:

$$F_{\text{grav}} = \vec{F}_g \cdot \vec{s} = F_g \cdot s = m \cdot 10 \cdot 1,5$$

and he says, ‘that is equal to the change in kinetic energy’ and he writes on the board:

$$[K = \frac{1}{2} mv^2] = \Delta K = \frac{1}{2} mv^2 - 0$$

He says, ‘work done by gravitational force is equal to change in energy’.

## Appendix 2B – Extended course

Part 1: Lecturer and students start at **L** → **C** → **L** → **C** for 4 minutes (from 0 to 4 minutes)

- Sub-part 1a is coded as **Linking** level. For 1 minute the lecturer asks the students: ‘say anything that you know about energy’.
- The students answer, ‘energy cannot be destroyed or created, however, it can be transferred’ and he writes that on the OHP, then he unpacks the words and says, ‘transference, it is a word that says, from one system to another system, or ‘it has been transformed, means from one kind of energy to another kind of energy but within that system, therefore, transformed means from the different form and transferred means from one system to another’. Then a student asks the lecturer to repeat the explanation of the words ‘transferred’ and ‘transformed’.
- Sub-part 1b is coded as **Concrete** level. For 1 minute the lecturer then responds to this request with a demonstration – by lifting a pen up to show that at that position, and says, –‘a pen exists in a gravitational force field of the earth; as an object, a pen possesses a gravitational potential energy; as it falls it loses the gravitational potential energy, so the gravitational potential energy decreases. But immediately, that energy is transformed to kinetic energy. Transformed means the total energy of the system is still the same but the energy is in different form’.
- Sub-part 1c is coded as **Linking** level. For 1 minute the lecturer asks, ‘anything else about energy?’ The students respond, and he writes on an OHP, ‘energy is the ability to do work’. He then unpacks that definition and says, ‘if I have energy in a system, that system has a capacity to do work on another system or object’.
- Sub-part 1d is coded as **Concrete** level. For 1 minute the lecturer unpacks and uses a verbal example – an explosion of a car – to explain the definition and he explains in depth this explosion and demonstrates the situation. While the lecturer is explaining, a student comments that the example used is unpleasant.

Part 2: Lecturer and students move from **C** → **L** → **A** for 4 minutes (from 4 to 8 minutes)

- Sub-part 2a is coded as **Linking** level. For 1 minute the lecturer asks the students to look at their notes and read the definition of energy. He then reads this out loud with the students. He

reminds them that tomorrow is the due date for the students to hand in their summaries for this chapter and the following one.

- Sub-part 2b is coded as **Abstract** level. For *3 minutes* the lecturer then he uses the definition from the notes, repacks the definition and writes the explanation of mechanical energy symbolically on the OHP:

$$E_{mech} = K \text{ (kinetic)} + U \text{ (potential)}$$

- He then says, ‘so if the two energies are added together, the sum is mechanical energy ( $E_{mech}$ )’.
- He then mentions that there are many forms of energy that students can learn about but for this course they will just learn about mechanical energy and he shows them the other types and writes that symbolically on the OHP:

$$E_{total} = [E_{mech}] + E_{thermal}$$

- He says ‘these (kinetic & potential energy) are at least the concepts that you’ve come across at school, so we’ll start there and unpack its fullness as we go along’.
- He asks the students to look at their notes, so that he can read with them the next definition – gravitational potential energy. He then writes that symbolically on the OHP:

$$U_g \rightarrow \text{gravitational potential energy}$$

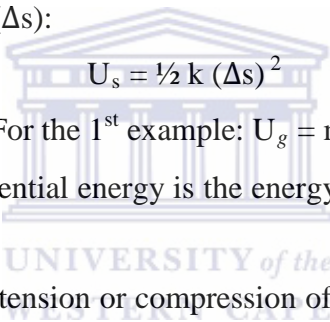
- He uses the concept of gravitational potential energy to explain conservative forces.

Part 3: Lecturer moves from A → L → C → L → A for *2 minutes (from 8 to 10 minutes)*

- Sub-part 3a is coded as **Linking** level. For *0.5 minutes* the lecturer unpacks the concept of conservative forces.
- Sub-part 3b is coded as **Concrete** level. For *0.5 minutes* the lecturer then demonstrates this with an example – take a pen and moves it up and down.
- Sub-part 3c is coded as **Linking** level. For *0.5 minutes* the lecturer continues by repacking and shows how an object gains and losses energy.
- Sub-part 3d is coded as **Abstract** level. For *0.5 minutes* the lecturer then explains the meaning of conservative (in terms of physics) – no net change in the total energy of the system.

Part 4: Lecturer moves from A → L → A → L → A → L → C for *6 minutes (from 10 to 16 minutes)*

- Sub-part 4a is coded as **Linking** level. For *1 minute* the lecturer unpacks the concept ‘conservative force’ and he uses a verbal example of a spring oscillating vertically up and down. He draws a sketch of the spring and writes the explanation of a spring symbolically on the OHP:
- Sub-part 4b is coded as **Abstract** level. For *1 minute* the lecturer uses the condensed symbols to show how the energy changes from one form to another.
- Sub-part 4c is coded as **Linking** level. For *1 minute* the lecturer then uses another example of a spring and draws another sketch of a spring that is being compressed or stretched horizontally. He shows in a sketch how the displacement ( $\Delta s$ ) changes with compression and extension.
- Sub-part 4d is coded as **Abstract** level. For *1 minute* the lecturer then condenses this example and writes the explanations symbolically on the OHP to show how the elastic potential energy is related to ( $\Delta s$ ):



$$U_s = \frac{1}{2} k (\Delta s)^2$$

For the 1<sup>st</sup> example:  $U_g = mgy$

- He then explains that, the potential energy is the energy that is purely a function of where the object is:  
in terms of the spring – it is the extension or compression of the spring and in terms of gravity – it is the height.
- Sub-part 4e is coded as **Linking** level. For *1 minute* the lecturer reminds the students about the first spring example showing what happens when the spring is compressed or stretched vertically.
- Sub-part 4f is coded as **Concrete** level. For *1 minute* the lecturer then demonstrates with another example – drops down a pen on the floor – to show increasing and decreasing of potential energy, also that the object has ability to do work – or it transforms energy within the system.

Part 5: Lecturer and students move from **C** → **A** → **L** → **A** → **L** for *5 minutes (from 16 to 21 minutes)*

- Sub-part 5a is coded as **Abstract** level. For *1 minute* the lecturer repacks from the concept of potential energy to other types and says ‘the other part of mechanical energy is kinetic energy’ and he writes that symbolically on the OHP:

$$K = \frac{1}{2} mv^2$$

- Sub-part 5b is coded as **Linking** level. For *1 minute* the lecturer then unpacks the formula, relates it to the other earlier topics in kinematics they have done and gives a verbal example of a ball travelling at a speed of  $10\text{m/s}^2$  or  $100\text{m/s}^2$ , to show the importance of speed in energy, he says ‘the speed determines how much energy you will get at the end’. He then asks the students, ‘is that example simple enough for you?’, then the students answer, ‘yes’.
- Sub-part 5c is coded as **Abstract** level. For *1 minute* the lecturer then repacks the concept of energy to show the meaning of total mechanical energy by adding together all the above mentioned energies, and he writes that symbolically on the OHP:

$$E_{\text{mech}} = K + U_s + U_g$$

- Sub-part 5d is coded as **Linking** level. For *2 minutes* the lecturer then relates this to the earlier sections of the Mechanics course: ‘this is the first time in this course that we are dealing with non-vector quantities’. He says, ‘all of these  $(K + U_s + U_g)$  are scalar quantities’, then he writes on the OHP: ‘- scalar quantities’. He says, ‘so therefore a positive or negative value there means something completely different to what positive and negative means when dealing with a vector; with a vector, positive and negative has a reference to the direction; with energy, positive and negative is defined in terms of the interaction of the system or the environment’. He then uses the formula to show that if, for example,  $U_g$  is negative it means ‘a number that is compared to the energy at some other point’. He then explains that in depth and writes on the OHP:

$\pm$  : different meaning

relates to state of the system

Part 6: Lecturer and students move from **L → A → L → C → L → A** for *4 minutes (from 21 to 25 minutes)*

- Sub-part 6a is coded as **Abstract** level. For *0.5 minutes* the lecturer repacks this to introduce the concept of conservation of energy, and says, ‘there are various conditions under which the mechanical energy of a system is conserved’, and writes this on the OHP:



$E_{\text{mech}}$  is conserved

- Sub-part 6b is coded as **Linking** level. For *2 minutes* the lecturer then asks the students, ‘under what conditions do you think the mechanical energy could be conserved in a system?’ and the students were confused about the question and then he explains that in depth and shows them in terms of a use of a formula, what he means, he writes this on the OHP:

$$\Delta E_{\text{mech}} = 0$$

- Then after the detailed explanation, the students answer, ‘when the system is isolated’. He then asks ‘what does an isolated system mean?’ then the students answer, ‘when the net external force is equal to zero’, he then writes that on the OHP:

Isolated system

$$\vec{F}_{\text{net}} = 0$$

- Sub-part 6c is coded as **Concrete** level. For *0.5 minutes* the lecturer then asks, ‘any other ideas – in what condition is mechanical energy conserved?’ The students were not responding and so he simplifies the question by means of a demonstration – ‘suppose I push a box [he pushes the box] and then stops – why does it stops?’
- Sub-part 6d is coded as **Linking** level. For *0.5 minutes* then the students respond – ‘it is friction’. They link the demonstration to the concept of conservation of mechanical energy.
- Sub-part 6e is coded as **Abstract** level. For *0.5 minutes* the lecturer then uses the students’ explanation to introduce another physics term to abstract from the demonstration, and he writes that on the OHP:

No dissipative forces/agents

Part 7: Lecturer and students move from A → A → L → C) for *5 minutes (from 25 to 30 minutes)*

- Sub-part 7a is coded as **Abstract** level. For *2 minutes* the lecturer uses these new concept and says, ‘for isolated and non- dissipative systems, we say that, the total kinetic energy is conserved, and basically what we are saying is that the total work done on the system is equal to zero’. He then writes that symbolically on the OHP:

$$W_{\text{total}} = 0$$

- And then he says, ‘what I’m introducing now is the new concept called work’. He asks, ‘what do you guys remember about work from school?’ The student answer, ‘it is the amount of energy used’.

- Sub-part 7b is coded as **Linking** level. For 2 *minutes* the lecturer then unpacks the concept of work with a sketch and relates energy to the familiar concept of Newton 2<sup>nd</sup> Law and then.
- Sub-part 7c is coded as **Concrete** level. For 1 *minute* the lecturer then uses a concrete example to demonstrate how he lifts and pushes a block – and then explains the concept of work in terms of interaction of particles within a system.

Part 8: Lecturer moves from C → L → A → L → A → L for 5 *minutes* (from 30 to 35 *minutes*)

- Sub-part 8a is coded as **Linking** level. For 0.5 *minutes* the lecturer repacks that example in terms of recapping on what he and the students had said about energy and work done, then relates that to work.
- Sub-part 8b is coded as **Abstract** level. For 1.5 *minutes* the lecturer uses this relationship to introduce the concept of ‘dot product’ – he says that, ‘in terms of the definition, work done by the force F is simply the dot product of that force with the displacement of the object’. He then condenses this explanation and writes it symbolically on the OHP:

$$W_F = \vec{F} \cdot \Delta \vec{r}$$

- Sub-part 8c is coded as **Linking** level. For 1 *minute* the lecturer then unpacks and explains the meaning of the dot product in terms of the units and he then writes that symbolically on the OHP:

$$\text{N.m} \equiv \text{J}$$

- Sub-part 8d is coded as **Abstract** level. For 1.5 *minutes* the lecturer continues and explains why it is called a dot product – and he says, ‘it is because of the dot between vectors A and B: a mathematical symbol to express a vector operation, i.e.  $\pm$  vector’. Then, he writes this symbolically on the OHP:

$$\vec{A} \cdot \vec{B} \text{ vector operation}$$

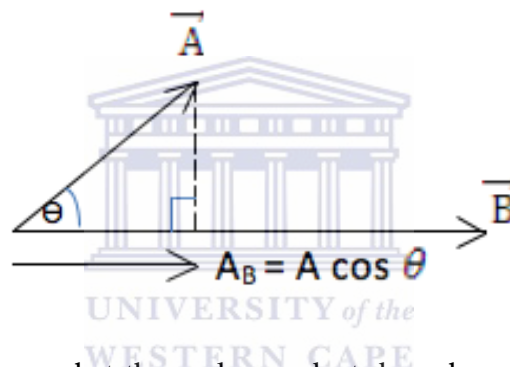
- He then says, ‘the dot product is a vector operation, however the more possibly correct way of expressing the dot product is as the “scalar product” because it is a product of multiplying the two vectors, which is a scalar’. Then, he writes this on the OHP:

scalar product :– product of  $\times$  two vectors together is a scalar

- Sub-part 8e is coded as **Linking** level. For *0.5 minutes* the lecturer continues, unpacks the concept of the “scalar product” and says, ‘if I take two vectors and multiply them together, the answer is not a vector anymore, the directional aspect of it is lost and we are left with a number that expresses something about how the two now look as a product’.

Part 9: Lecturer and students move from **L** → **A** for *4 minutes (from 35 to 39 minutes)*

- This part is coded as **Abstract** level because the lecturer uses a diagrammatical representation to condense what he means about the dot product, he says, ‘if I have vector A’, then he draws vector  $\vec{A}$  at an angle, and then says, ‘I’ve got another vector B’, then he draws vector  $\vec{B}$  horizontally. He then asks the students, ‘can you see those vectors are not in the same direction?’



He then explains the diagram – what the scalar product does, he says, ‘it drops one vector down perpendicular to the other vector’, and he then draws that as shown in the diagram above, to show a component of vector  $\vec{A}$  along vector  $\vec{B}$ . Then he explains that ‘it is a multiplication of the magnitudes of the two scalars  $A_B$  and  $B$ ’. Then continues and explains in depth the diagram. He writes the explanations symbolically on the OHP:

$$A_B \times B$$

$$\vec{A} \cdot \vec{B} = A \cos \theta B \quad \text{polar co-ordinates of vectors}$$

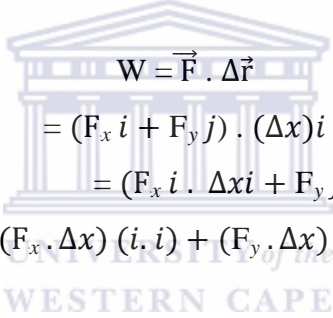
$$W = \vec{F} \cdot \Delta \vec{r}$$

$$= F \cdot \Delta r \cos \theta$$

- He then asks the students whether the explanation is clear enough and they say, yes it is.

Part 10: Lecturer and students move from **A** → **L** for *9 minutes (from 39 to 48 minutes)*

- This part is coded as **Linking** level because the lecturer asks the students to look at their notes so that they can read the example. He then reads out loud the example and unpacks it. He then reminds the students that what they have done at part 9 above was to evaluate work using the rule of polar co-ordinates of vectors and he writes that on the OHP next to the symbolically explanation. So he suggests that instead of using the rule of polar co-ordinates of vectors they must also use the rule of components. He explains the formula of work done ( $W = \vec{F} \cdot \Delta\vec{r}$ ) in the form of  $i$  and  $j$  notation from the earlier lessons on Vectors. And then he asks the students what they have done in the Mathematics course in terms of the dot product and the students confirm that they have done that part of the work. Then he explains and relates the explanations to the students' knowledge of Vectors and Mathematics. While explaining, he asks questions from the students and during this interaction between lecturer and students, the following explanation gets written on the OHP, with each step being discussed in-depth:



$$\begin{aligned}
 W &= \vec{F} \cdot \Delta\vec{r} \\
 &= (F_x i + F_y j) \cdot (\Delta x) i \\
 &= (F_x i \cdot \Delta x i + F_y j \cdot \Delta x i) \\
 &= (F_x \cdot \Delta x) (i \cdot i) + (F_y \cdot \Delta x) (j \cdot i)
 \end{aligned}$$

$$\begin{array}{l}
 \rightarrow i \\
 \rightarrow i
 \end{array}
 \left. \begin{array}{l}
 \text{same direction} \\
 \theta = 0^\circ
 \end{array} \right\}
 \left. \begin{array}{l}
 \\
 \cos 0^\circ = 1
 \end{array} \right\} (i \cdot i)$$

$$\begin{array}{l}
 \uparrow \\
 \rightarrow
 \end{array}
 \left. \begin{array}{l}
 j \\
 i
 \end{array} \right\} j \cdot i$$

$$\begin{aligned}
 &= 1 \times 1 \times \cos 90^\circ \\
 &= 1 \cdot 1 \cdot 0 \\
 &= 0
 \end{aligned}$$

$$\begin{aligned}
 \therefore &= (F_x \cdot \Delta x) (i \cdot i) + (F_y \cdot \Delta x) (j \cdot i) \\
 &= (F_x \cdot \Delta x) (i \cdot i) + 0
 \end{aligned}$$

$$\begin{aligned}
 &= (F_x \cdot \Delta x) \times 1 + 0 \\
 &= \cos 0^\circ
 \end{aligned}$$

[N.B. Class activity takes place here: 37 minutes (in the 7 last minutes of the first lecture, the lecturer gives students a problem task, and in the first 30 minutes of the second lecture, students had to finish the task in groups). The problem task is that of a passenger carrying a suitcase up a flight of stairs, with the students needing to calculate the work done by the passenger]

- The lecturers and the teaching assistants move around the class to look and monitor the progress of each group. For example, if there is a common misconception, then the lecturer will address the whole class and share the concern or guide the students on how to go about solving the problem. He also writes these points on the OHP:
  - draw a sketch;
  - identify the agents, position & state of energy
  - indicate these before (at start, initially) and after (end, final)
  - draw a force & displacement diagram to evaluate the work done by the individual forces and the net force
  - $W = \vec{F} \cdot \Delta\vec{r}$ 
    - both have:  $\vec{F}$ :  $i$  &  $j$  components and  $\Delta\vec{r}$ :  $i$  &  $j$  direction
    - displacement vector is  $\Delta\vec{r} = \Delta x i + \Delta y j$

Part 11: Lecturer and students move from L → L → C for 6 minutes (from 90 to 96 minutes)

- Sub-part 11a is coded as **Linking** level. For 2 minutes the lecturer asks students to volunteer and write their solutions on the OHP. While one group is writing the solution, the lecturer moves around to look at the other groups' solutions. Then he finds out that one of the other groups misunderstands the task and so he intervenes and addresses the whole class to find out how they understand the task.
- Sub-part 11b is coded as **Concrete** level. For 4 minutes the lecturer then asks the students questions about the task, and then demonstrates how the object (the suitcase) is being carried

in the task. In between he asks questions to unpack the task, e.g. he says, ‘how are you carrying the suitcase? Is the suitcase’s speed increasing? If you look at the state of energy, the suitcase’s speed at start and at the end – is the same or not?’ The students respond to the questions and the lecturer continues to unpack the task with questions and explanations.

Part 12: Lecturer moves from C → L for 4 minutes (from 96 to 100 minutes)

- This part is coded as **Linking** level because the lecturer links the concrete example from the task (suitcase) to a more abstract representation and uses the students’ solution (FBD) to draw a sketch but he first simplifies the task. He shows the students on the sketch how the system looks like and where it is from the initial to the final state. Then he suggests that they should draw a FBD after the sketch, he notes, ‘can you see that I’m being explicit about the representations that I’m using here?; I’m saying this is the sketch, this is the FBD, and what is my system; I’m explicitly identifying what my system is’. He indicates in the sketch what he means about the system. He then writes everything on the OHP: e.g.

He draws and labels the sketch

FBD: (system is suitcase)

Part 13: Lecturer moves from L → A for 3 minutes (from 100 to 103 minutes)

- This part is coded as **Abstract** level because the lecturer uses the information the students know about the FBD (considering from the students’ solution) and draws another diagram (FBD) to show them gradually how to draw it in terms of work-energy and how to identify the significant information (i.e. how to link the displacement vector to the force vector). He then writes on the OHP:
- He draws a (dot) ● to identify the system and he then draws the forces

$\vec{F}_{P \text{ on } S}$  (you) P: Passenger

S: Suitcase

$\vec{F}_{E \text{ on } S}$  (gravity) E: Earth

Both  $\vec{F}_{net} = 0 \therefore \vec{a} = 0$

- He then explains in depth all the information needed to solve (i.e.  $\vec{F}$  &  $\vec{s}$  and  $\theta$  between these vectors) this problem in terms of work done and links to what the students already know about the FBD's.

Part 14: Lecturer and students move from **A** → **L** for 3 minutes (from 103 to 106 minutes)

- This part is coded as **Linking** level because a student asks a question, and the lecturer responds with a verbal example. After that he then continues with the lecture. He says, 'I want you to listen carefully' and suggests that, 'with consideration of conservation of energy and evaluation of work done', they should 'superimpose' a displacement vector and the angle if it is given. He draws that the diagrammatically. Then he emphasizes the importance, 'because the work done on an object by the force depends on the relative direction of the force vector and the displacement'. He shows them all of that on the diagram; also he draws the co-ordinate system to show the directions of the forces.

Part 15: Lecturer and students move from **L** → **A** → **L** for 3 minutes (from 106 to 109 minutes)

- Sub-part 15a is coded as **Abstract** level. For 1 minute the lecturer uses the diagram to answer the question in the problem task – what is the work done by the force. He requests the students to read, look at the diagram and tell him 'in question 2.1, which of the two forces were you asked to calculate?'
- Sub-part 15b is coded as **Linking** level. For 2 minutes the lecturer looks back to the question and asks the class to read the question, 'how much work does the passenger do?', then he paraphrases the question, 'which means, the work done by the force'. He suggests that to answer the question they have to use the FBD. Then he asks them to look at the diagram and tell him 'which of the two significant forces are we talking about?' and they respond.

Part 16: Lecturer and students move from **L** → **A** for 3 minutes (from 109 to 112 minutes)

- This part is coded as **Abstract** level because the lecturer uses the students' responses to repack and writes the solution in terms of work done on the OHP:

$$W_{\vec{F}_{P \text{ on } S}} = \vec{F}_{P \text{ on } S} \cdot \Delta \vec{r}$$

- He shows them the importance of putting subscripts when identifying the forces, he says, ‘you should identify the force that the agent exerts on the system; you don’t just take any force and plug it in the equation, you have to identify what exactly those forces are’. He explains in-depth how the students could see which force they need to use.

Part 17: Lecturer and students move from A → L for 5 minutes (from 112 to 117 minutes)

- This part is coded as **Linking** level because the lecturer uses the diagram to show the displacement vector, the angle and the significant force they have to use to calculate work done. Then he uses  $i$  &  $j$  notation to solve the problem. He explains in-depth, asking questions from the students, for instance: ‘does the force that the passenger exerts on the suitcase have an  $x$  component? (students answer ‘no’); look at your FBD; what is the magnitude of force  $F_{P\ on\ S\ yj}$ ? (students answer ‘215N’) how do we know that? (students explain); what is the displacement in the  $x$  direction? (students answer ‘4.6m’); what is the angle between  $j$  &  $i$ ?; do you understand why it is  $0^\circ$ ?; and he explains: ‘the angle between  $j$  &  $i$  is  $90^\circ$ , so  $\cos 90^\circ$  is equal to zero, so this dot product 215N & 4,6mi is zero’. Then he writes the solutions on the OHP:

$$\begin{aligned}
 &= (F_{P\ on\ S\ xi} + F_{P\ on\ S\ yj}) \cdot (\Delta xi + \Delta yj) \\
 &= (0 + 215j) \cdot (4,6mi + 4.2mj) \\
 &= (215) \cdot (4.2m)j \cdot j \\
 &= 903 \cdot 1 \\
 &= 903\text{ J}
 \end{aligned}$$

**He ends the lecture by giving students warm-up task, i.e. the students need to do the same as he did above, but now they have to use a component form.**



### 3. Interview questions with students tackling a physics task

#### Appendix 3A – Mainstream course physics task interview questions

##### Question 2

- 2.1. If you were not told to draw the FBD, do you think you would have needed to draw it? Why?
- 2.2. *If drawn a point particle:* what is the meaning of the dot?  
*If not drawn:* in your Knight textbook, FBDs are drawn like this: (show the students a drawing of a FBD from the textbook). What do you think the meaning of the dot is? Why do you think Knight model the block as point particle? Can you think of a situation where we wouldn't be able to model it as a point particle?
- 2.3. What do these arrows tell us?
- 2.4. What assumptions did you make when simplifying this problem? (ignore air resistance, assume rope's mass is negligible, assume block as point particle, choosing a co-ordinate system). If they can't answer, then ask, why the term 'light ropes' was specified in the problem?
- 2.5. Why is it important to make these assumptions?
- 2.6. How do you know that angle  $\theta$  is  $37^\circ$  for the 5kg block?
- 2.7. What is the sign of the side opposite angle  $\theta$ ? Why is it ...?
- 2.8. Was it necessary for you to find the value of this side? Why?
- 2.9. Why did you choose the co-ordinate system the way you did in each block?

## Appendix 3B – Extended course physics task interview questions

### Question 2

- 2.1. What is the system in this question? Why do you need to identify the system and the agents?
- 2.2. If you were not told to draw the FBD, do you think you would have needed to draw it? Why?
- 2.3. What is the meaning of the dot?
- 2.4. Can you think of a situation where you wouldn't be able to model an object as a point particle?
- 2.5. What assumptions did you make when simplifying this problem?
- 2.6. Why is it important to make these assumptions?
- 2.7. What do the arrows tell us?
- 2.8. Why are the sizes of the arrows the same/different?
- 2.9. As indicated in this question, why is it necessary to choose the co-ordinate system?
- 2.10. Why is it necessary to show explicitly the acceleration/ $F_{net}$  in your diagram?
- 2.11. What is the purpose of breaking the forces into components for the force acting at angle  $30^{\circ}$ ?
- 2.12. Was it necessary for you to find the values of these components? Why?

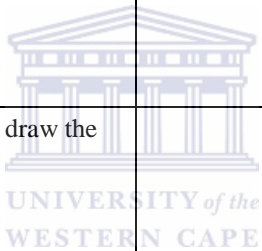
- 2.13. How did you know which value should you use/substitute for the coefficient of friction?
- 2.14. Why did you write two subscripts for the forces?
- 2.15. In class, I often hear your lecturers saying that they are trying to get you all “to think like a physics person and do things like a physics person would”. What do you think about that?.(...) Do you feel you are learning to think like a physics person, or just learning to get marks and to pass at the end?

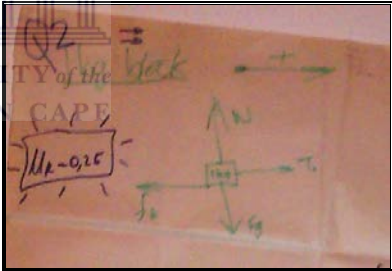


## 4. An example of the data table

### Appendix 4 – Students’ use of representations when tackling a physics task (Mainstream Group 1)


**Question 2a: Draw a free body diagram for each block**

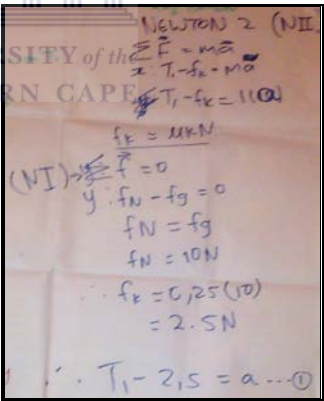
| Parts of the lecture and the time taken     | Expected or ideal representations for the physics task – (external LoD)   | How the students uses representations in the physics task | What is written on the news-print (i.e. words, sketches, diagrams, symbols, equations) | Coding comments  | Position and shifts in the application of Newton’s 2 <sup>nd</sup> Law |
|---|---|---|--|--|--|
| 1<br>0.5 minutes<br>(from 0 to 0.5 minutes) | <p><b>Verbal representation (written or words)</b></p> <ul style="list-style-type: none"> <li>- read the problem carefully</li> <li>- sketch the situation</li> <li>- identify the object of interest (the system)</li> <li>- draw a circle around the object of interest</li> <li>- identify the external objects or forces interacting with the system</li> </ul> | <p>- Reading in order to draw the FBD’s</p>               |      | <p>- There was nothing discussed or written down to show that the students were unpacking the problem: The students do not unpack the problem in order to identify each block as a system or draw a circle around each block, and identify the external objects or forces interacting with each system (i.e. identify the agents).</p> | <p>Reading and unpacking</p>   |
| 2<br>0 minutes                              | <p><b>Pictorial representation (particle model)</b></p> <ul style="list-style-type: none"> <li>- represent the objects as a point</li> </ul>  |   |  | <p>- The modelling part is skipped over: the students drew the sketches of the</p>   | <p>No modeling</p>   |

|  |   |   |  |  |                  |
|--|---|---|--|--|------------------|
|  | <p>particle</p> <ul style="list-style-type: none"> <li>- make simplifying assumptions when interpreting the problem statement</li> </ul>  |   |  | <p>three blocks while they were drawing the FBD's as indicated in the physical representation below. Moreover, they do not model each block as point particle, they do not identify each block as a system, they do not discuss how the three blocks will move together, also they do not think about what the concept 'light rope' means.</p> |                  |
| <p>3<br/>5 minutes<br/>(from 0.5 to 5.5 minutes)</p> | <p><b>Physical representation (FBD)</b></p> <ul style="list-style-type: none"> <li>- identify all the forces acting on the object</li> <li>- establish a coordinate system to identify signs</li> <li>- represent the object as a dot at the origin of the coordinate axes – particle model</li> <li>- translate on the FBD the components for an inclined surface</li> <li>- draw force vectors representing all the identified forces (lengths represent the relative magnitudes)</li> <li>- label all the forces in the diagram (with two subscripts)</li> <li>- draw and label the vector <math>F_{net}</math></li> </ul> | <p>The students do the following:</p> <ul style="list-style-type: none"> <li>- Identify the block to start with (i.e. <u>1kg mass</u> on the horizontal surface)</li> <li>- Choose and indicate the direction of the motion (+ →) besides the diagram</li> <li>- Name all the forces acting</li> <li>- Draw the identified sketch of the block</li> <li>- Draw the FBD for 1kg mass and labelled the force vectors with symbols, e.g. normal force: <math>N</math> up, force of gravity: <math>F_g</math> down, tension 1: <math>T_1</math> right &amp; friction: <math>f_k</math> left</li> </ul> <p>After some deliberation about which block to focus on next,</p> | <p>FBD for the 1kg mass</p>  <p>FBD for the 2kg mass</p> | <p>After the students had drawn the FBD from the 1kg mass, <b>they</b> were not certain which mass they should focus on next. It seemed that this was because they had not unpacked the problem earlier and recognised the connection between the blocks.</p>  | <p>Visualize</p> |

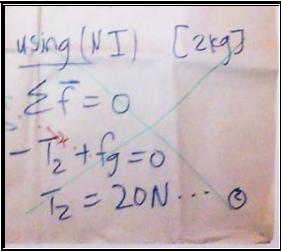
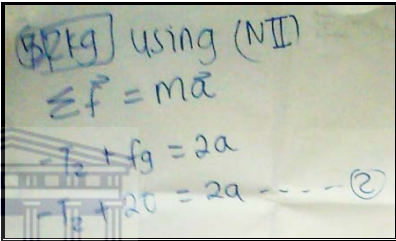


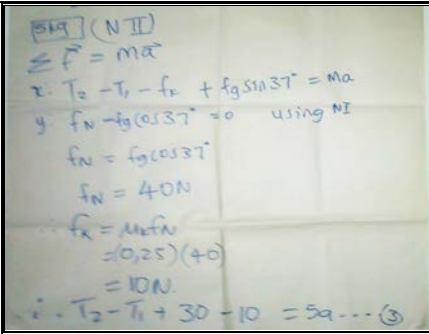
**Question 2b: Use Newton's 2<sup>nd</sup> Law to set up equations of motion for the three blocks**

| Parts of the lecture and the time taken | Expected or ideal representations for the physics task – (external LoD)  | How the students uses representations in the physics task | What is written on the news-print (i.e. words, sketches, diagrams, symbols, equations) | Coding comments   | Position and shifts in the application of Newton's 2 <sup>nd</sup> Law |
|---|--|---|--|---|--|
| 4<br>0 minutes                          | <p><b><i>Pictorial representation (particle model)</i></b></p> <ul style="list-style-type: none"> <li>- represent the objects as a point particle</li> <li>- make simplifying assumptions when interpreting the problem statement</li> </ul>   |   |      | <ul style="list-style-type: none"> <li>- This group skipped this part of representation; they directly jumped over to the mathematical representation stage, to solve the problem using the FBD's for the three blocks. Therefore, this group did not make any assumptions in simplifying the problem.</li> </ul>                     | No modeling  |
| 5<br>0 minutes                          | <p><b><i>Physical representation (FBD)</i></b></p> <ul style="list-style-type: none"> <li>- identify all the forces acting on the object</li> <li>- establish a coordinate system to identify signs</li> <li>- represent the object as a dot at the origin of the coordinate axes – particle model</li> <li>- translate on the FBD the components for an inclined surface</li> </ul> |   |  | <ul style="list-style-type: none"> <li>- This group skipped this part and go directly to solve using the FBD's for the three blocks;</li> <li>- This group did not use the FBD to help them identify the appropriate law (Newton 2<sup>nd</sup> law) in certain parts of the problem, as this is shown in the column below</li> </ul> | Visualize  |

|  |  |   |  |   |  |
|--|--|---|--|---|--|
|  | <ul style="list-style-type: none"> <li>- draw force vectors representing all the identified forces (lengths represent the relative magnitudes)</li> <li>- label all the forces in the diagram (with two subscripts)</li> <li>- draw and label the vector <math>F_{\text{net}}</math> or the acceleration of the motion</li> <li>- translate the problem into symbols (define symbols for masses and for the interaction)</li> <li>- identify the desired unknowns</li> </ul>   |   |  |   |  |
| 6a<br>21.5 minutes<br>(from 5.5 to 26 minutes) | <p><b>Mathematical/quantitative representation (Newton's 2<sup>nd</sup> Law)</b></p> <ul style="list-style-type: none"> <li>- identify the law (first write the required law/equations for calculating the unknowns)</li> <li>- find <math>F_{\text{net}}</math> for the parallel sides and the perpendicular sides (the components for the inclined surface should be included in these sides)</li> <li>- use explicit subscripts throughout this representation, each referring to a symbol that was defined in the physical representation/FBD</li> <li>- replace the symbols with numerical values defined in the physical representation</li> </ul> | <p>The students do the following:<br/>For the <u>1kg block</u>:</p> <ul style="list-style-type: none"> <li>- identify the law i.e. Newton 2<sup>nd</sup> law</li> <li>- simplify the law: NII: <math>\sum \vec{F} = m\vec{a}</math></li> <li>- choose the positive direction for <math>T_1</math> &amp; <math>f_k</math>, simplify the law: <math>x: T_1 - f_k = m\vec{a}</math></li> <li>- students were confused in choosing a positive direction in the y axis,</li> <li>- they write <math>\sum F = 0</math> and label this as Newton 1<sup>st</sup> law ('N1'),</li> <li>- they choose a direction ('down is positive') to find the value for FN and <math>f_k = \mu kFN</math> because they say FN is in the y direction</li> </ul> | <p>The use Newton 2<sup>nd</sup> law for the 1kg mass</p>  <p>The use Newton 2<sup>nd</sup> law for the 2kg mass</p> | <ul style="list-style-type: none"> <li>- The students were confused about whether to indicate the positive direction for x or y axes, since they only indicate positive for the direction of motion (i.e. in the direction of x axes) and not draw the coordinate system to specify both x or y axes for each block. As a result, they used Newton 1<sup>st</sup> law to find the unknowns for the y direction in their calculation for the 1kg block as they start by identifying the 1<sup>st</sup> law as (N1): <math>\sum F = 0</math>. Therefore here, the students</li> </ul> | <p>Solve: identify and use Newton 2<sup>nd</sup> law</p> |



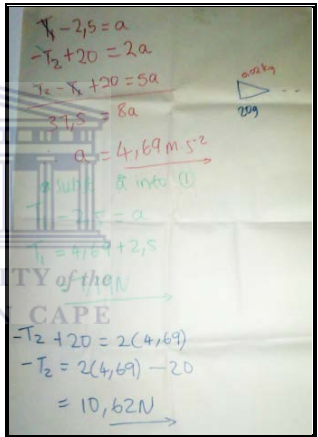
|  |  |  |  |   |  |
|--|--|--|--|---|--|
|  |  | <p>- as they write and simplify the law: <math>F_N - F_g = 0</math> other group members suggest 'take up as positive'.</p> <p>- they substitute the values for <math>F_g</math></p> <p>- find the unknown <math>f_k</math> by substituting the given value for <math>\mu k</math> which is 0,25 and multiply by the calculated value of <math>F_N</math></p> <p>- simplify and write the equation number:</p> $T_1 - 2,5 = \vec{a} \dots (1)$ <p>For the <u>2kg block</u>:</p> <p>- write equation: (N1): <math>\sum F = 0</math></p> <p>- simplify into: <math>-T_2 + F_g = 0</math></p> <p>At this point, they argue about whether the block is stationary or accelerating.</p> <p>One student argues for <math>\sum F = 0</math> being valid, by suggesting: 'When you're doing it with the diagram, you have to look at these things separately'.</p> <p>But another student disagrees: 'If the whole system is moving, then each thing is moving!'.</p> <p>Despite the fact that the problem statement explicitly states that the blocks are 'in motion' and that the system is</p> |  <p>using (NI) [2kg]</p> $\sum \vec{F} = 0$ $-T_2 + f_g = 0$ $T_2 = 20N \dots \textcircled{1}$<br> <p>[5kg] using (NII)</p> $\sum \vec{F} = m\vec{a}$ $-T_2 + f_g = 2a$ $-T_2 + 20 = 2a \dots \textcircled{2}$ <p>The use Newton 2<sup>nd</sup> law for the 5kg mass</p> | <p>identified Newton 1<sup>st</sup> instead of 2<sup>nd</sup> law to find the unknowns.</p> <p>Until this point, they have not discussing the physical situation of the problem statement, and now argue about this.</p> <p>They don't talk about the blocks as connected to one another, Since <math>\sum F = 0</math> in y-direction for the 1kg block, they start by assuming this for the 2kg block.</p> <p>This is despite the fact that the problem statement explicitly states that the blocks are 'in motion' and that the system is accelerating.</p> <p>When they review the test script, they use the solution from the test script and change the equation <math>\sum F = 0</math> to <math>\sum \vec{F} = m\vec{a}</math>.</p> <p>They do this without referring back to their</p> |  |
|--|--|--|--|---|--|

|  |  |   |   |  |
|--|--|---|---|--|
|  |  | <p>accelerating, the students decide that there is no net force on the 2<sup>nd</sup> block, and by implication, no acceleration. They write this mathematically as: '<math>\sum F = 0</math>'</p> <p>They then ask the scribe to check her test script to see how she had done this problem. They see that she had written:</p> <p>(NII) <math>\sum \vec{F} = m\vec{a}</math></p> <ul style="list-style-type: none"> <li>- find the direction 'down is positive' and substitute the forces: <math>-T_2 + \vec{F}_g = 2\vec{a}</math></li> <li>- substitute the value of <math>F_g</math> then simplify and write the equation number:<br/> <math>-T_2 + 20 = 2\vec{a} \dots (2)</math></li> </ul> <p>For the <u>5kg block</u>:</p> <ul style="list-style-type: none"> <li>- identify Newton 2<sup>nd</sup> law, write:<br/> NII: <math>\sum \vec{F} = m\vec{a}</math></li> <li>- indicate <math>x</math> and <math>y</math> direction, simplify the law into forces, <math>x</math>:<br/> <math>T_2 - T_1 - f_k + F_g \sin 37^\circ = ma</math></li> <li>- find components for <math>F_g</math> since the block is in an inclined plane</li> <li>- identify forces acting in <math>y</math> direction:<br/> <math>y: F_N - F_g \cos 37^\circ = 0</math></li> </ul> |  | <p>earlier argument about whether the block was stationary or accelerating, and to the physical situation of the problem.</p> <ul style="list-style-type: none"> <li>- Interestingly, the students label the case where <math>\sum F = 0</math> as Newton's 1<sup>st</sup> law – 'using N1'</li> <li>- All in all this part suggests that this group do not have a full understanding of Newton's 2<sup>nd</sup> in terms of whether the object is accelerating (<math>\sum \vec{F} = m\vec{a}</math>) or not (<math>\sum \vec{F} = 0</math>).</li> </ul> <p>The confusion at the abstract, mathematical representation stage of the problem arises because the students had not spent enough time reading and making sense of the concrete physical problem situation. They had not</p> |
|--|--|---|---|--|

|  |  |  |  |   |  |
|--|--|--|--|---|--|
|  |  | <ul style="list-style-type: none"> <li>- write, 'using N1' if the sum of the forces is equal to zero</li> <li>- find the value for FN using the formula: <math>f_k = \mu kFN</math></li> <li>- substitute the values for <math>\mu k</math> &amp; FN to find the unknown</li> <li>- substitute the values to equation:</li> </ul> $T_2 - T_1 - f_k + F_g \sin 37^\circ = ma$ $T_2 - T_1 - 10 + 30 = 5a \dots(3)$ |  | <p>established at this early stage the obvious point that all three attached blocks would have identical motion, and that they were accelerating and not stationary. They did not model the problem or draw careful FBDs as tools to think about the sizes of the force vectors, which would have helped them to consider the size and direction of the net force</p> |  |
|--|--|--|--|---|--|



**Question 2c: Find the acceleration of the system and the tensions  $T_1$  and  $T_2$**

| Parts of the lecture and the time taken        | Expected or ideal representations for the physics task – (external LoD)   | How the students uses representations in the physics task  | What is written on the news-print (i.e. words, sketches, diagrams, symbols, equations)   | Coding comments  | Position and shifts in the application of Newton's 2 <sup>nd</sup> Law |
|--|---|--|--|--|--|
| 6b<br><br>5 minutes<br>(from 26 to 31 minutes) | <p><b>Mathematical/quantitative representation (Newton's 2<sup>nd</sup> Law)</b></p> <ul style="list-style-type: none"> <li>- identify the law (first write the required law/equations for calculating the unknowns)</li> <li>- find <math>F_{net}</math> for the parallel sides and the perpendicular sides (the components for the inclined surface should be included in these sides)</li> <li>- use explicit subscripts throughout this representation, each referring to a symbol that was defined in the physical representation/FBD</li> <li>- replace the symbols with numerical values defined in the physical representation</li> </ul> | <p>The students do the following:</p> <ul style="list-style-type: none"> <li>- use simultaneous equations to calculate acceleration</li> <li>- identify the appropriate equations to calculate acceleration</li> <li>- add equations (1), (2) &amp; (3) found in the previous sub question</li> <li>- substitute the value for acceleration to equation (1) to find the unknown tensions <math>T_1</math> and equation (2) for <math>T_2</math></li> </ul> | <p>The solution for <math>a</math>, <math>T_1</math> &amp; <math>T_2</math></p>  | <ul style="list-style-type: none"> <li>- The students identify the appropriate equations they have to use in calculating the acceleration, <math>T_1</math> and <math>T_2</math>.</li> </ul> | <p>Solve:decide which mathematical representation to use</p>           |
| 7<br><br>0 minutes                             | <p><b>Assess the problem</b></p> <ul style="list-style-type: none"> <li>- check whether the result is reasonable</li> <li>- provide a final concluding</li> </ul>   | <ul style="list-style-type: none"> <li>- No assessment has been done by the students</li> </ul>  |  | <ul style="list-style-type: none"> <li>- In this part, the students have not assessed the problem: have not evaluated the final results</li> </ul>   | <p>No assessment</p>   |

|  |   |  |  |   |  |
|--|---|--|--|---|--|
|  | statement wherein you interpret the mathematics solution in the context of the problem<br>- check whether the result has correct proper signs and units |  |  | or verify the answer from the questions. They also have not check and refer the final results back to the context of the problem. |  |
|--|---|--|--|---|--|



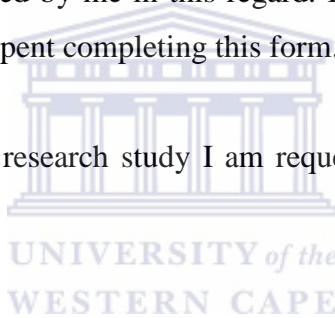
## 5. Ethics Documents

### Appendix 5: Students' Participation Pre-request

Read through carefully the contents of this request before coming to a decision whether you are interested in participating in this research.

I am currently conducting a research with lecturers and students to explore the learning experience associated with a curriculum that is designed to develop academic literacy in physics. I will be observing lectures/classes and interviewing both students and lecturers to see and hear their perceptions, also I will ask you to answer a survey questionnaire. I hereby request a permission from you to collect the data for this research study. I will only be interviewing a small sample of students and you might be contacted by me in this regard. I appreciate your empathy in handling my request and the time you have spent completing this form.

If you agree to participate in this research study I am requesting you to read and sign/initial in the letter below.



### Letter of Consent

1. Honjiswa Conana is conducting a research to explore the learning experience associated with a curriculum that is designed to develop academic literacy in physics.
2. You have been requested to participate in this research study. Honjiswa will observe you in class, interview you and record the interview, she will also ask you to answer a survey questionnaire.
3. The results obtained in this research study will be used towards a Doctoral degree through University of the Western Cape. In addition, the results will also be used for writing papers for presentation at conferences and publication in academic journals.

I .....  
hereby agree voluntarily to participate in this research study on the understanding that I will be anonymous. I understand that I am entitled to withdraw my agreement to participate from this research at any point should I change my mind.

Signature:..... Date: .....

School leaving exam (e.g. NSC matric cert/other): .....

Degree: .....

Year of study: .....

Course of study: .....

Contact number: .....

Email address: .....

Suitable time to be contacted: .....

