



UNIVERSITY *of the*  
WESTERN CAPE

# A Semiotic Analysis of User Manuals for Two Blender Brands

A thesis submitted in fulfilment of the requirements for the degree of  
Magister Artium in the Department of Linguistics, University of the Western Cape.



2855127

January 2016

Supervisor: Professor Bassey Antia

## **KEYWORDS**

User Manuals

Consumer Protection Act of South Africa (CPA)

Product Experience

Comprehension

Readability

Terminology

Multimodality

Genre

Sentence Structure

Optimization

User Empowerment

Usability



## **ABSTRACT**

### **A Semiotic Analysis of User Manuals for Two Blender Brands**

**Leanne Jense**

**MA Thesis, Department of Linguistics, University of the Western Cape**

Technical documentation comes in a variety of forms such as installation or operation manuals, quick reference guides, maintenance manuals, user manuals, policy and procedure manuals or marketing brochures and flyers (Walsh, 2012). What all these sub-genres have in common is that the texts that correspond to them seek to inform and give instruction about procedures, behaviour and actions related to products (Schäffner & Wieseemann, 2001: 49). Manuals have been described as “the complete reference source for a product’s operation, maintenance and safety” (Cowley & Wogalter, 2011: 1773). For the purpose of this study, we will focus on one form of technical documentation, namely user manuals. The terms “documentation” and “manuals” will be used interchangeably.

Although there are probably as many manuals as there are products in our homes, these user manuals have not frequently been the subject of academic study in the South African context. The relative lack of research into user manuals is especially regrettable at a time when new product liability legislation and trade regulations (e.g. the Consumer Protection Act of South Africa, 2008) have enhanced the profile of product manuals in public and regulatory discourse. As a result of this relative neglect, it is not known how understandable, relevant and therefore empowering users of products find these manuals. There is also not much knowledge concerning the level of compliance in manuals to the provisions of product liability legislation.

This study therefore proposes to investigate the comprehensibility and usability of user manuals associated with two products (blenders) marketed in South Africa. It will draw on theories and methods of analysis associated with technical writing, analysis of terminological consistency, genre and multimodality, to evaluate the selected manuals from the standpoint of a subset of the

criteria listed in Section 22(2) of the Consumer Protection Act of South Africa, No. 68 of 2008, which was later amended in 2011. The methodology for the proposed study will combine text analysis (by the researcher) with comprehension and usability tasks performed by selected participants. Data from these sources will be collated and analysed to determine the conformity of the manuals to criteria in the Consumer Protection Act of South Africa, and the effect the manuals have on product users. Areas for optimising (improving) the manuals will also be identified.



## DECLARATION

I declare that *A Semiotic Analysis of User Manuals for Two Blender Brands* is my own work and that it has not been submitted as a report for any degree or examination in any other university, and that all the sources I have used or quoted have been indicated and acknowledged by complete references.

Leanne C.L JenseL

January 2016

Signed:



## **ACKNOWLEDGEMENTS**

First and foremost all honour, praise and glory to God. I thank God for the blessings, endurance, patience and wisdom that He has granted me to achieve what I have. Without Him, it would not have been possible.

To my parents, sister and husband, thank you for believing in me when times got tough, for your unconditional love and support, continuous prayers, encouragements and motivation. You make life the blessing that it is. May God's continuous favour always be upon you.

To the rest of my family, my in-laws and extended family, thank you for encouraging me to persevere and to never back down.

Professor Bassey Antia, thank you for having so much faith in me. Thank you for your patience, praises and for simply being such a great inspiration and an empowering supervisor. May your future endeavours always be blessed.

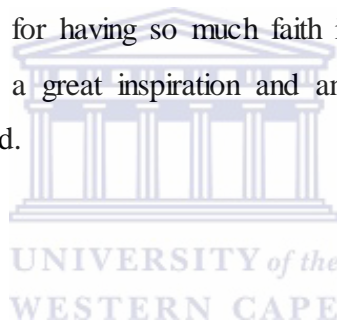

## TABLE OF CONTENTS

Keywords

Abstract

Declaration

Acknowledgements

Contents

### **Chapter 1: Introduction**

1.0 Background on manuals

1.1 Research problem

1.2 Research aims and objectives

1.3 Chapter outline

### **Chapter 2: Literature review and theoretical approaches**

2.0 Introduction

2.1 User manuals

2.2 Genre

2.3 Readability

2.4 Terminology

2.5 Multimodality

2.6 Sequencing of information and sentence structure

2.7 Standards of textuality



### **Chapter 3: Research methodology**

3.0 Research design and methodology

3.1 Manuals to be analysed

3.2 Research design

3.3 Participating respondents

3.4 Data collection instruments

3.5 Data analysis

3.6 Limitations of the study

### 3.7 Ethical considerations

## **Chapter 4: Theoretical analysis of the product manuals**

### 4.0 Introduction

#### 4.1 Logik manual observations

- 4.1.1 Multimodal aspects of the Logik manual
- 4.1.2 The use of terminology and inconsistency in the Logik manual
- 4.1.3 Misleading information in the Logik manual
- 4.1.4 Grammatical errors and problems of word choice in the Logik manual
- 4.1.5 Omitted and implied information in the Logik manual
- 4.1.6 Sequencing of information and sentence structure in the Logik manual
- 4.1.7 A brief summary of the Logik manual

#### 4.2 Ottimo manual observations

- 4.2.1 Multimodal aspects of the Ottimo manual
- 4.2.2 Organisation of information in the Ottimo manual
- 4.2.3 Inconsistency in the use of terminology
- 4.2.4 Grammatical and word choice issues in the Ottimo manual
- 4.2.5 A brief summary of the Ottimo manual

## **Chapter 5: Analysis of user views and experiences**

### 5.0 Introduction

#### 5.1 An analysis of the recipients involved in the study

#### 5.2 Logik manual questionnaire interpretations

- 5.2.1 Introduction
- 5.2.2 An account of responses to the Logik manual questionnaire
- 5.2.3 A brief summary of the Logik manual findings

#### 5.3 Ottimo manual questionnaire interpretations

- 5.3.1 Introduction
- 5.3.2 An account of responses to the Ottimo manual questionnaire
- 5.3.3 A brief summary of the Ottimo manual findings
- 5.3.4 Conclusion



5.4 Findings based on an analysis of task performance (video clips)

5.4.1 Introduction

5.4.2 A summary of the performance task findings

## **Chapter 6: Conclusions and Recommendations**

6.0 Summary

6.1 Recommendations for improving the manuals

### **Appendices**

Appendix 1 – Information Sheet for Task Performance

Appendix 2 – Information Sheet for Questionnaire

Appendix 3 – Logik Manual Questionnaire

Appendix 4 – Ottimo Manual Questionnaire

### **References**



# CHAPTER 1

## INTRODUCTION

### 1.0 Background on manuals

According to Schoff and Robinson (1991: 1), manuals are the “*how-to* books for owners and operators of a product.” These manuals exist in the form of instruction manuals, service manuals, user manuals or even training manuals, installation or operation manuals and quick reference guides, to name a few (Ramaker, 2007; Walsh, 2012). They function as instructive texts and are an important part of conveying a message across which ensures successful operations (Shäffner & Wieseemann, 2001: 49).

Manuals generally follow certain generic (genre-related) conventions: complimentary remarks about the product and the decision to buy it, followed by warnings, basic instructions and ending with warranties/guarantees and service information (Shäffner & Wieseemann, 2001: 51). There is documentation required at every stage of a product’s life cycle, from conception and design through manufacturing, testing, marketing, installation, maintenance, repair and disposal.

The products for which documentation is provided can range from furniture and motor vehicles, through food and medicines, to computer and electronic gadgets, aircrafts and ships. The presentation of these manuals or the manner in which they are offered to users ranges from one-page pamphlets to booklets with thousands of paragraphs as well as electronic formats.

According to Mehlenbacher (2003: 10), “documentation includes both hardcopy and online support materials that help users achieve goals and accomplish tasks within the contexts of their primary work.” Technical documents used to be paper documents in the past but have now evolved to use other support media such as CD-Rom or DVD, online websites and downloadable files (Ramaker, 2007). These new media make accessing product/service information easier for the buyer or reader (in some cases). This new form of media and technology also make it easier for manufacturers to make necessary updates over time without having to reinvest in printing costs (Ramaker, 2007: 6).

According to Ramaker (2007: 7) “online websites and downloadable files have become popular over the past 20 years due to convenience and accessibility to the buyer or reader and are now also a way of saving money on the production of hardcopies by the manufacturer.” Instead of producing bulky manuals, manufacturers produce shortened versions on paper and provide much more in-depth, follow-up information on a CD-Rom or even provide a usable website link for further detailed information and contact details. Indeed, Ramaker (2007) states that “what used to be seen as a piece of text is now a resource” and the way information is produced of late and the way it is presented, has evolved tremendously.

The subject of user manuals is an interesting one for at least three reasons. The first reason has to do with claims and counter-claims concerning the use of manuals. Sullivan and Flower (1986: 170) found that product documentation tends to be too complex to understand or focuses too much on the features of the software or hardware that it supports, thereby making the reader lose interest. As a result, consumers feel a sense of irritability or disempowerment, and then ask someone else for assistance or guidance, use the internet to research other possible methods (or even products), try to figure out the problem without the use of manuals, or eventually give up trying (Novick & Ward, 2006).



Some other studies, on the other hand, blame product users and not the manuals. Manufacturers’ perceptions regarding manuals are that consumers do not bother reading manuals from the beginning to the end. Mehlenbacher *et al* (2002: 733) concluded that readers are often impatient and want to get productive, thereby skipping and skimming through manuals. Mehlenbacher (2003: 2) states that nobody particularly reads documentation unless they think they need to and when they eventually do read the documentation, “they satisfice, skip, scan, and skim.”

Ramaker’s (2007) view suggests that because manufacturers perceive that product users do not spend time reading manuals, they (manufacturers) too tend not to invest resources in producing quality manuals. This perception is of some concern and there is clearly a need to address these claims and counter-claims.

Apart from the need to address these claims and counter-claims, a second reason for academic interest in user manuals has to do with the changing nature of product liability legislation. As it has been pointed out (Antia, 2014: 507; Göpferich, 1998: 40), in some environments product liability laws, which in the past were limited to only material defect in products, have now been extended to issues arising from faulty documentation. In South Africa, we get a sense of this new trend from the Consumer Protection Act (CPA) of 2008. Rubinstein (2011) describes the Act's strict concept of liability as follows:

“In terms of Section 61 of the CPA, a producer, importer, distributor or retailer of goods is liable for any harm or damage caused wholly or partly as a result of the following:

- the supply of unsafe goods,
- a product failure,
- defect or hazard in the goods,
- *inadequate instructions or warnings provided to the consumer pertaining to any risk associated with the use of the goods regardless of whether the harm resulted from any negligence on the part of the producer, importer, distributor or retailer.*” (italics mine).

UNIVERSITY of the

(Rubinstein, 2011; [http://www.gov.za/sites/www.gov.za/files/32186\\_467\\_0.pdf](http://www.gov.za/sites/www.gov.za/files/32186_467_0.pdf))

The italicised passage shows that a producer is liable for harm or damage caused by problems in the documentation. It is not only the quality of the product that is of concern, but the quality of the documentation too. Should a consumer injure himself or herself due to a factor such as incorrect information, or even the lack of information, the manufacturer will be held legally responsible. Clearly, this new regulation makes it interesting to find out whether product manufacturers are giving sufficient attention to product documentation.

In a South African context, a third reason or set of reasons for the interest in user manuals, beyond the mere fact of product liability legislation being extended to documentation, is the very detailed nature of provisions in Section 22(2) of the South African Consumer Protection Act of 2008. Section 22(2) of the CPA states the following:

(2) “For the purposes of this Act, a notice, document or visual representation is in plain language if it is reasonable to conclude that an ordinary consumer of the class of persons for whom the notice, document or visual representation is intended, with average literacy skills and minimal experience as a consumer of the relevant goods or services, could be expected to understand the content, significance and import of the notice, document or visual representation without **undue effort**, having regard to—

(a) the context, **comprehensiveness and consistency** of the notice, document or visual representation;

(b) the **organisation, form and style** of the notice, document or visual representation;

(c) the **vocabulary, usage and sentence structure** of the notice, document or visual representation; and

(d) the use of any **illustrations, examples, headings or other aids to reading and understanding.**”



South Africa imports a number of items<sup>1</sup> and it cannot always be ascertained that product documentation legislation in countries from which imports originate is even comparable to the CPA of South Africa<sup>2</sup>. Regrettably, according to the Import Control Regulations of South Africa (2012), printed books, newspapers, pictures and other products of the printing industry, including manuscripts, typescripts and plans, do not go through the same registration and import permission process as goods which include ammunition, food supplies, vehicles and so forth.

---

<sup>1</sup> According to Trading Economics (2015), South Africa’s main imports are: fuel (24% percent of total imports), nuclear reactors, boilers, machinery and mechanical appliances (14%), motor vehicles and car parts (9%), telephone sets (3%), pharmaceuticals (2%), vegetables (2%) and live animals and animal products (1%).

<sup>2</sup> Foreign manufactured products imported into the country are equally subject to the CPA. Chirwa (2012: 12), citing Peter *et al.* (2007:1) and Standard Bank, (2011: 2), states that “the CPA firmly places the responsibility for ensuring adequate standards of goods and services in the hands of those who provide them. The consequences of not complying can be serious, and there is no room for complacency: every business that transacts with consumers needs to take a long, hard look at their products, services, business methods and terms of trade.” It is therefore of great importance and concern that the products marketed in South Africa, whether produced locally or not, need to comply with the regulations as stipulated in the CPA to avoid any injuries, law suites, damages or further serious issues such as death.

This, in other words, means that imported documentation may not be as closely scrutinised as the goods and services they accompany at the time of entering the country.

### **1.1 Research Problem**

In the South African context, language and the access it provides to knowledge and information have been widely researched and documented, with results revealing that language is a means of empowering or disempowering groups and communities through enabling or disabling access to information and knowledge in sectors such as education, public services, and so on.

However, little research attention has been paid to the link between language and empowerment, or disempowerment, in the context of product user manuals. This is in spite of product liability legislation and trade regulations (e.g. the Consumer Protection Act of South Africa, 2008) that have enhanced the profile of product manuals in public and regulatory discourse. As a result, our knowledge is relatively inadequate with respect to the level of compliance in manuals to the provisions of product liability legislation. It is also not widely known how understandable users of products find these manuals or how well they can use these manuals to carry out typical tasks. We also do not know if the public's perception of the quality of product manuals affects their perception of the product. Finally, we do not know the extent to which claims and counter-claims in the international literature actually apply to South African product users.

In an article published online by Fin24 (2011), Neil Kirby, director at Werksmans Attorneys, stated that consumers' rights take precedence over suppliers' rights and that suppliers now have to understand and act on what is required of them in order to provide the necessary terms and conditions of their contracts, or other forms of documentation, in plain and understandable language, and to also align their business practices with the CPA legislation.

Kirby (2011) further pointed out that "such compliance is important as it is the use of plain and understandable language that arguably represents the future of contractual relations in South Africa."

The above therefore creates a need to analyse and investigate the current relationship between language (structures), documentation and consumer laws and regulations in South Africa.

## **1.2 Research Aim and Objectives**

Against the backdrop of the foregoing sections, this study examines two user manuals associated with kitchen blenders marketed in South Africa. The objectives of the study are as follows:

1.2.1 To draw on theoretical concepts to evaluate the text of the manuals from the standpoint of their compliance to relevant provisions of the Consumer Protection Act.

1.2.2 To obtain users' views on how the semiotic resources employed in the manuals affect the readability and intelligibility of the manual.

1.2.3 To determine the extent to which typical or potential product owners can use the manuals to carry out specific tasks with the product.

1.2.4. To identify strategies for optimizing or improving the manuals.

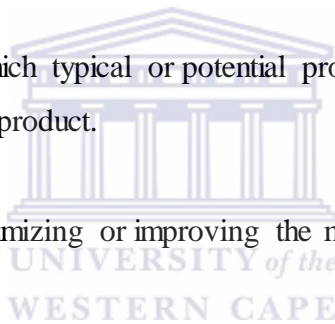

## **1.3 Chapter Outline**

Chapter one provides the introduction of the research thesis. It introduces the reader to the research topic, including the background of manuals, and includes the statement of the problem and objectives of the study.

Chapter two presents the literature relevant to the study from which theoretical constructs are derived. It reviews literature on user manuals (Novick & Ward, 2006; Jansen & Bilijon, 2002; Freeman, 2003; Mehlenbacher, 2003); describes readability measures and formulas such as the “Flesch-Kincaid approach” used to determine the complexity of sentences; terminological consistency (Antia 2000, 2001; Schmitz, 2007; Rogers, 2008); genre (Shäffner & Wiesemann, 2001; Ramaker, 2007; Hyland, 2008; Johnstone, 2008); multimodality (Woolever, 1999; Kress & Van Leeuwen, 2007; Schriver, 1997; and Stöckl, 2009); and standards of textuality in relation to text and visuals (de Beaugrande & Dressler, 1981).

Chapter three discusses the research methodology for this study. This section explains why both quantitative and qualitative research methods were used and how the study benefited from both. This section also describes the two manuals analysed in great detail; the data collection procedure; the research participants; data analysis and the limitations of the study as well as the ethical considerations which were relevant to this study.

Chapter four presents and discusses the data on the theoretical analysis of the manuals as carried out by the researcher. This section provides an analysis based on the theoretical constructs addressed in chapter three. It analyses and discusses issues such as manual layout, language use, sentence construction and so on.

The data analysis in chapter five is divided into two sections. Part one presents, analyses and discusses the data relevant to the questionnaire responses. These are discussed in detail as per respondents' replies and experiences whilst answering the questionnaire together with the manual. Part two presents and analyses the data from the recordings of participants using the manuals to assemble the kitchen blender.

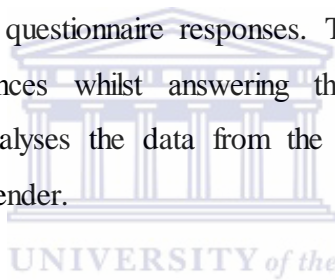

Chapter six concludes the study. It summarises the issues in the manuals and also makes recommendations for improving the manuals and it suggests topics for further study.



## CHAPTER 2

### LITERATURE REVIEW AND THEORETICAL APPROACHES

#### 2.0 Introduction

The provisions in Section 22(2) of the Consumer Protection Act (2008) of South Africa (henceforth, CPA) can be seen as a listing of parameters for assessing product manuals. In fact, they evoke a number of constructs in the theoretical literature and can serve as a framework for the proposed study. For instance, provisions on vocabulary, consistency and a product user being spared “undue effort”, evoke research on such topics as terminology and readability index. Provisions related to organisation, form and style of a document call to mind literature on genre. Illustrations and relationships between the visual and the text are addressed by the literature on multimodality. Issues of context, comprehensiveness of information, cohesion and other elements are addressed by de Beaugrande and Dressler’s (1981) standards of textuality. In this chapter, literature on each of these topics is reviewed. However, I’ll first review the literature on user manuals.

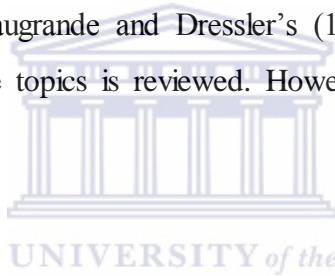

#### 2.1 User Manuals

There is an extensive body of international research on user manuals, examining a range of subjects (product user preferences, their attitudes to manuals, the contents of manuals, etc.). In a research study conducted by Novick and Ward (2006), participants indicated that there were several aspects they preferred in a manual. Whether online or in print form, participants preferred documentation in which they could find information easily; in which they were provided with details and necessary explanations; problem solving techniques with the help of images and examples, as well as correct and complete content.

Numerous researchers (Novick & Ward, 2006; Jansen & Bilijon, 2002; Freeman, 2003; Mehlenbacher, 2003) have found that consumers or product owners do not read manuals but simply skim through manuals for relevant documentation before using the product. This often becomes a problem when consumers find that the product does not operate to its full potential, or end up injuring themselves or damaging the product as a result of not knowing how to operate it correctly.

In a study relating to instructions, enhanced performance and learning, Eiriksdottir and Catrambone (2011) distinguished between three types of instructions, namely, procedural instructions, principles and examples. They briefly explain that procedural instructions describe the process by explaining each step; principles provide information about rules and regularities governing the task, and lastly, examples demonstrate how the action of the task is carried out, and these are usually without accompanied explanations (2011: 750). In addition to the three types of instructions, Carver (1990: 145) adds that there are also three major components of effective manuals, namely logical organisation; appropriate language use and syntax; and a design which enhances accessibility and readability.

From these basic explanations, it is safe to assume that a majority of product manuals largely make use of a combination of procedural instructions, principles as well as examples. Needless to say, this is evident in the fact that basic instructions need to be provided in a step-by-step manner in order for the user to follow and understand; certain rules and regulations are provided to ensure the safety of the customer as well as the image of the company producing and marketing the product; and examples are presented in a way that makes the step-by-step instructions easier for the reader to understand.

Schoff and Robinson (1991: 3) highlight the importance of consumer safety, stating that “one important component of product liability law is the manufacturer’s duty to warn.” Manuals have to be designed not only to educate or inform the user, but to warn as well. They go on further to say that “an operator manual and its warning frequently become key documents in product liability suits. Therefore, if the manual is well designed and worded, it may help protect the manufacturer against charges of failure to give adequate warning” (1991: 3). Schoff and Robinson (1991: 3) sum it up adequately and state that “the manual sends a message to the buyer of the product. A poorly designed, confusing or unreadable manual may cast doubt on the quality of the product itself or convince a user not to purchase from the particular company...”

The point about information quality and consumer safety is reiterated in a study conducted by Chirwa (2012: 1), citing Carlin and Gervais (2010), who argues as follows:

*“The protection of the consumer is very important in each and every market, particularly in the South African context. The more vulnerable consumers are, the more protection is required. In the past many consumers suffered losses, damages, injuries, or death caused by improper business practices, including the supplying and selling of hazardous products, product failure, misleading information, advertising, direct marketing, and poor instructions. These issues were more or less linked to producers, suppliers, retailers, and anyone in the supply chain who is in a position of selling goods or services directly to consumers.”*

## **2.2 Genre**

Paragraph ‘b’ of Section 22(2) of the CPA mentions the following as an issue relevant to product information: *“the organisation, form and style of the notice, document or visual representation.”* In other words, consumers should be able to understand product information *“without undue effort”* related to issues of organisation. This requirement calls attention to genre theory.

According to Hyland (2008: 543) “genre represents how writers typically use language to respond to *recurring situations*, pointing to the fact that texts are most successful when they employ conventions that other members of the community find *familiar and convincing*.” Kress (1998: 183) defines a genre as “a kind of text that derives its form from the structure of a *repeated social occasion*”, with its characteristic participants and their purposes; and lastly, Johnstone (2008: 184) defines genre as “a *recurrent* verbal form (or text type) associated with a *recurrent* purpose or activity.” What these three definitions all have in common are the synonymous words *“recurring, repeated and recurrent.”* Texts of particular genres conform to specific conventions and people draw on background knowledge and shared contexts to understand them.

Research (Shäffner & Wiesemann, 2001; Ramaker, 2007) has identified the generic features of user manuals. These features include: the manufacturer congratulating the consumer on buying an excellent, reliable product and introducing it to him/her; the product brand and an image resembling the item are displayed on the first pages of the manual; basic sets of instructions

describing troubleshooting techniques and warnings regarding the product; the “how to” instructions relating to the usage of the product; the do’s and don’ts as well as contact information, guarantees/warranties and service information are all found in a typical product manual (Shäffner & Wiesemann, 2001; Ramaker, 2007).

When consumers are advised to refer to a manual, they immediately have an idea of what a manual should look like and what sort of information to expect therein. Genre theory is relevant to manuals or other forms of technical documentation, especially because users are able to easily locate the information they need if a manual conforms to the format or text structure of a relevant genre.

Thus, users expect the texts to correspond to the genre conventions with which they are familiar (Shäffner & Wiesemann, 2001: 50). According to Ramaker (2007: 7) “technical documents should be well organised by using recognisable tags, relevant divisions of text and images, lists or tables and identifiable sections by the use of headings and subheadings” which will assist the reader in locating the desired information.

One of several studies in which the genre dimension in technical documents is critically highlighted is the study by Maat and Lentz (2011). Maat and Lentz (2011) examined medication information leaflets and found that patients had difficulties locating information relating to ingredients that were used in the medication, the side effects thereof or the directions for use. The backdrop to this study was a 1988 directive by the European Union to pharmaceutical companies to base their patient information leaflets on a template addressing four aspects: (1) the content elements that must be present; (2) the order in which these topics should be discussed; (3) the headings to be used for paragraphs and subparagraphs; and (4) the wording of a number of specific passages.

The structure and the headings of the European template were as follows: (1) What is Y and what is it used for; (2) before you take Y; (3) how to take Y; (4) possible side effects; (5) how to store Y; and (6) further information (Maat & Lentz, 2011: 199). Maat and Lentz sought to find out the extent to which the template benefitted readers of patient information and to what degree

it possibly hindered easy access to information. For the study, Maat and Lentz (2011: 201) recruited 46 participants and had them each scan a leaflet for one minute before being questioned about what they had read and possibly understood.

The results indicated that patients could not find the relevant information under headings where they expected to find it. The results indicated that readers preferred the following structure for a leaflet: (1) the goal of the medicine; (2) directions for use; (3) potential problems; and (4) packaging and storage. The European Union's template therefore did not match users' expectations concerning the leaflet's structure (Maat & Lentz, 2011: 199).

From what Maat and Lentz (2011) found, we see that readers disapproved of the modification of an established generic structure. Since readers have become familiar and have learned the genre, they are capable of visualising and remembering a mental representation of a typical leaflet structure (Maat & Lentz, 2011: 199).

### **2.3 Readability**

The CPA expects product information to be easily understandable by persons with “*average literacy skills and minimal experience.*” This requirement makes the construct of readability relevant to this research. Readability refers to how easy or difficult it is to read and understand a text (DuBay, 2007: 4). A text is readable when it is agreeable and attractive in style (DuBay, 2007; Stephens, 2000).

The Ohio Literacy Resource Centre in the USA addressed the issues of readability and considered relative factors that influence text difficulty, including the following:

- A reader's interest in the text or background knowledge.
- Unfamiliar, abstract, and difficult-to-decode words which tend to make for difficult reading.
- Syntax or language patterns: repeated sentences or phrases which aid easy reading, as do rhyming patterns and other predictable features. Long,

complex sentences and sentences written in passive voice, which are more difficult to read.

- Internal organisation: the clarity (or lack) of presentation of ideas affects readability. Well organised expository texts with clear statements of purpose followed by complete discussions of key points are easier to read than texts organised in some other way.
- Contextual support: textbook-like texts may have (or lack) features such as headings, graphics, illustrations, and so forth, which can affect readability.
- Format: font size, length, and even the appearance of the text on a page can cause a text to “look” more or less difficult to read. (<http://literacy.kent.edu/Oasis/Pubs/0300-45.pdf>).

From the above factors, we find that there are a number of important and often overlooked factors which influence the ease of reading and understanding. According to Stephens (2000), readability tests, which are mathematical formulas, were designed to assess the suitability of texts at particular grade levels or ages. In one of the earliest studies on the subject, Smith and Senter (1967: 1) claimed that the readability of a document greatly influences the time required to extract needed information from the document. Likewise, it influences the probability that the information extracted will be correctly understood and used (Smith & Senter, 1967: 1).

According to Stephens (2000), readability formulas are usually based on one semantic factor (the difficulty of words) and one syntactic factor (the difficulty of sentences). Words are either measured against a frequency list or are measured according to their length in characters or syllables, whereas sentences are measured for the average length in characters or words.

Rudolph Flesch was one of the first researchers to discover readability formulae. Together with John Kincaid, Flesch developed the “Flesch-Kincaid approach” which was a readability formula used by the United States Navy ([www.readabilityformulas.com](http://www.readabilityformulas.com)) and was based on navy training manuals. It measures texts using the following standard mathematical formula:  $FK = (0.39 \times \text{average number of words per sentence}) + (11.8 \times \text{average number of syllables per word}) - 15.59$ . High scores (90-100) indicated very easy reading and low scores (0-29) indicated difficulty and

confusion ([www.readabilityformulas.com](http://www.readabilityformulas.com)). This approach has since become a popular measurement of the level of difficulty in technical documents (Akinci, 2010).

According to Terranova *et al* (2012: 650), other popular readability measures are the Gunning Fog approach and the Dale-Chall readability formula. The Gunning Fog approach, which takes into account the level of complex words and sentences, is measured using a standard mathematical formula of:  $\text{Grade Level} = 0.4[(\text{number of words divided by number of sentences}) + (\text{Percentage complex words})]$ ; where percentage complex words is equal to the total count of words of three or more syllables divided by the total number of words in the text ([www.readabilityformulas.com](http://www.readabilityformulas.com)).

Unlike the other formulas that use word length to assess difficulty, the Dale-Chall formula uses a count of complex words not familiar to common 4<sup>th</sup> grade United States school-goers. It draws on a lengthy mathematical equation:  $[\text{Raw Score} = (0.1579 \times \text{Percentage of complex words}) + (0.0496 \times \text{Average sentence length in words})]$ ; where if the percentage of complex words is more than five percent then the mathematical equation is adjusted to:  $(\text{Raw Score} + 3.6365)$  producing an adjusted score of a reader who is able to grasp a text at 4<sup>th</sup> grade level. Adjusted scores of 4.9 and below relate to 4<sup>th</sup> grade levels and below, whereas scores of 10 and above relate to College students ([www.readabilityformulas.com](http://www.readabilityformulas.com)).

In one study of a technical document in which the Flesch-Kincaid method was used, Terranova *et al* (2012) evaluated current informed consent forms (developed according to the recommendations of scientific societies), and compared them to a revised consent form which they developed on the basis of reference standards which require plain language and the use of relevant information for the patient to make adequate decisions concerning his/her health. After patients completed either the current or revised informed consent forms, Terranova *et al* (2012: 652) analysed both texts (using the Flesch-Kincaid method) and found that readability was improved with the revised form.

Although readability formulae are based on studying words and sentences, there are certain factors that cannot be measured (Stephens, 2000). According to Terranova *et al* (2012: 650),

“quantifiable factors such as structural complexity, grammatical correctness or meaning” are not taken into account. Stephens (2000) argues that readability test results do not reflect whether the text was of interest to the reader, whether the reader needed sufficient background information to grasp what was written or reveal how complex the statements and ideas were.

These readability formulae cannot categorise the class/race/gender/language of the reader and also says nothing about how appropriate the vocabulary, content and style are for the audience. Most importantly, the formulae “cannot adjust for the needs of readers for whom the text is written in a second or additional language” (Stephens, 2000). Subsequent sections therefore focus on other aspects of a text (or manual) that can affect understanding.

## **2.4 Terminology**

Terminology refers to words that are used to designate concepts of a specific subject matter or domain (Antia, 2000). According to Rogers (2008: 60) “in technical writing, precision of terms is prized above elegance of expression, given that the function of most technical documents is informative or instructive.” Rogers (2008: 59) further explains that consistency of terminology has been seen as a good feature of technical writing and also an advantage of technical (machine) translation over human translation.

According to Schmitz (2007), terminology is a means of communication and knowledge transfer and the language and terminology used in manuals need to be appropriate for the target group so that they are able to understand the terms and information conveyed to operate the product correctly and efficiently. However, a major problem in the use of terminology is maintaining consistency. In Section 22(2a), South Africa’s CPA highlights consistency as an issue in the understanding of product information.

To illustrate the challenge which terminological consistency presents, Antia (2001: 22, citing de Beaugrande, 1997) for instance, invites us to place ourselves in the position of a science writer for a non-specialized audience:



*[s/he] tries to state an original theory of communication while defining the technical terms clearly and using them consistently (it's harder than you'd think!). You might just write down a few phrases, sentences, or paragraphs and then critique and rephrase others, trying to anticipate the problems for the readers, who won't already have the ideas organised in their minds as well as you do. Or you might not even have them organised yourself and might be waiting to see where they lead – the “brainstorming” that classical scientific discourse conceals from public view (de Beaugrande, 1997: 160).*

The challenges of terminological consistency are found in all situations and contexts. For example, Antia (2001: 22) analyses inconsistency in a text on parliamentary procedure and points to analyses of inconsistency of terms in a variety of other areas, such as the philosophy of science, economics and even automotive engineering.

In one study of terminology in product documentation, Schmitz (2007) points to how inconsistent use of terminology in product documentation affects user experience of the product. He gives the example of a computer keyboard key being inconsistently referred to as the “Enter” key on one page and then “Return” key on another page within a manual. This inconsistent use of terminology leaves the consumer confused and frustrated because of possible time wasted trying to figure out the problem.

In another study, Woolever (1999: 201) cites the example of “unvalcanized” and “devulcanized” that are obviously intended as synonyms, but eventually leave the reader wondering if one or two different concepts are so designated. Woolever (1999: 201) stresses that in writing, one should determine what the key terms are to communicate the technical information clearly and then to use these terms consistently in all parts of the text.

Consumer confidence is only increased when the use of terminology is consistent (Schmitz, 2007: 55). Schmitz (2007: 55) furthermore concludes that “establishing terminological consistency is one of the most important aspects of user-friendly software products and therefore of user-empowerment.”

## 2.5 Multimodality

In Section 22(2) of the CPA of South Africa, reference is repeatedly made to “*notice, document or visual representation*” and in paragraph “d” to “*the use of any illustrations ... or other aids to reading and understanding.*” These references acknowledge the presence of several semiotic modes in manuals and make it relevant to discuss multimodality. Kress and Van Leeuwen (2001: 20) define multimodality as “the use of several semiotic modes in the design of a semiotic product or event, together with the particular way in which these modes are combined.” According to Stöckl (2009: 206) “multimodality is the co-presence of various semiotic modes in a given overall text.” Furthermore, Stöckl (2009: 206) states that the “essence of multimodality seems to be that the various modes are integrated and interrelated.” Among the major modes are language, pictures, colour and sound. The purpose of this combination is to clarify, simplify, emphasize and summarise information; to attract and impress the reader; or to save space in hardcopy manuals (Woolever, 1999: 126).

According to Stöckl (2009: 205), “the more senses and semiotic modes that are employed in communicative tasks, the more effectively meaning can be conveyed and negotiated.” In order to get the message conveyed, the modes need to have synergy between them, but also relate to the users’ knowledge, culture, experience and values (Schriver, 1997: 166).

Schriver (1997: 412-413) lists five relationships between text and images. The first relationship, *redundancy*, refers to “key ideas and concepts which are repeated or paraphrased in the document. Similar ideas are presented in alternative representations, media or senses” (Schriver, 1997: 412). For example, hardcopy newspaper or product manual editions which are also available online for further reading, or children’s fairytale story books made available in the form of an audio CD. Redundancy can be very useful if used in the right context, for example, when one cannot fully understand a concept and would therefore need further information or clarity (Mäkynen, 2012: 31). However, if redundancy is over-used, the reader may feel that the writer underestimates his or her intelligence (Schriver, 1997).

The second relationship introduced by Schriver is *complementarity*. According to Schriver (1997: 415), text and images complement each other by conveying different aspects of the

content. They both work together and help the reader to understand the message that the writer is trying to get across. Consider the example of a cellphone accompanied by its user manual: the images in the manual describe to the user where the SIM card should be inserted into the cellphone, while the text describes how it should be inserted – with the data chip either facing upwards or downwards, for example.

Texts and images can also be arranged in such a way that the one mode conveys more information than the other mode, thereby being the dominant mode, whilst the other simply supports and elaborates. Schriver (1997: 419) calls this relationship *supplementary*. When information provided in a document or contract is too complicated for users to understand, they are given *supplementary* information either in the form of a sidebar or appendices providing further information. The fourth relationship that Schriver (1997) introduces us to is the *juxtapositional* relationship. Schriver (1997: 424) explains that “when text and images interact, the main idea is created by a clash or tension between what is represented in each mode.” This form of relationship is often used in cartoons or advertising (Schriver, 1997: 424). The final relationship between text and images is *stage-setting*. Schriver (1997: 425) states that “in this relationship, one mode provides a context for the other mode by forecasting its content.” The aim thereof is to provide the reader with the bigger picture before s/he continues with the task. Mäkynen (2012: 33) provides the example of an image of a child using a cellphone which is placed at the beginning of the user manual to convey the idea that the particular phone is easy to use.

In addition to Schriver’s text-image relationships, Kress and Van Leeuwen (2006) suggest parameters for analysing the relations between image and text as parts of an integrated whole. They propose three parameters or “principal compositions”: information value, salience and framing (Kress & Van Leeuwen, 2006: 177). Kress and Van Leeuwen (2006) argue that the position a visual element holds, establishes its information value and importance within especially a larger textual composition. This position also establishes relationships amongst various elements and contributes to the construction of particular intended or derived meanings. According to Matthews (2009: 51), “information value refers to the position a visual element

holds within a larger textual composition within or across a quadrant realised through vertical and horizontal axes.”

This first principal composition, information value, can be analysed along three dimensions: *Given-New*, *Real-Ideal* and *Centre-Margin* (Kress & Van Leeuwen, 2006: 209). In brief, the *Given* refers to elements found on the left side which is everything left of the *Centre* of the composition and represents given or known information (Kress & Van Leeuwen, 2006: 180-181). Contrastingly, the right side of the *Centre* is known as the *New* and provides newer, fresher information. On a newspaper front page, for instance, everything to the left of the paper would be information that is already known to the reader as opposed to information on the right, which is new, fresh information.

The *Real* and the *Ideal* elements represent the vertical axis of a multimodal text. Matthews (2009) explains that the *Real* and *Ideal* are elements respectively polarized above and below a centred composition where the *Real* is considered more practical, unassuming information and the *Ideal* refers to more idealised information (2009: 52). Considering the example of a newspaper front page once more, the information presented on top is reserved for stating what could or should be, often taking the place of an article heading (ideal information), whilst the information presented at the bottom, tends towards the more informative, practical and current situation (real information) (Matthews, 2009: 52). Kress and Van Leeuwen describe the *Centre* as “element/s that are presented as the nucleus of the information to which all other elements are in some sense subservient” (2006: 196). In addition, Matthews (2009: 53) explains that “these ‘subservient’ elements refer to those that appear in the margin/s of a text”. Kress and Van Leeuwen (2006: 196) then state that “the *Margins* are these ancillary, dependent elements.”

The second principle of composition is *salience*, which refers to “elements which are made attractive to the viewers’ attention in differing degrees whether by size, contrast in colour and tone, differences in sharpness or positioning in the foreground or background of a text/image” (Kress & Van Leeuwen, 2006: 177). Kress and Van Leeuwen (2006: 201) explain that regardless of where the elements are placed on a page, “salience can create a hierarchy of importance among the elements, selecting some as more important and more worthy of attention than

others.” A vehicle dealership for instance will advertise their deals of the month, making their most desired vehicle the salient point of the advertisement by either increasing the size of the image compared to the other vehicles advertised or by adding colourful banners and borders around the feature vehicle.

*Framing*, the third compositional element, is brought about by rhythm (Kress & Van Leeuwen 2006: 203). Elements in a text/image can either be connected or disconnected. Kress and Van Leeuwen (2006: 201) state that with regard to visual framing, elements of the composition may be strongly or weakly framed. The stronger the framing of the element, the more it presents a separate unit of information. Kress and Van Leeuwen (2006: 204) explain that framing is usually indicated “by actual frames, by white space between elements, by discontinuities of colour.” This white colour or spaces can ‘frame’ a text by dividing or joining the visual and verbal aspects. In addition, Matthews (2009: 49-50) adds that “the notion of framing not only refers to how components are arranged on a page but also the background knowledge of what is being written or visualised.” Readers need to correctly interpret and make meaning of what is read, thereby relying on framing.

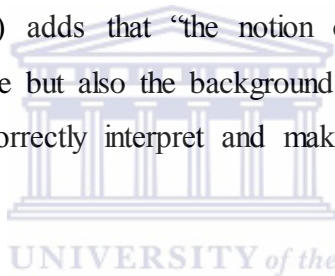

Let us consider another relevant framework of multimodal analysis. Stöckl (2009: 218) proposes three levels that may be useful in describing image-text relations, namely: *spatial syntax*, *info-content*, and *rhetorical logic*. Spatial-syntax patterns refer to how the text and image are designed on a page. Illustrating spatial-syntax, Woolever (1999: 137) advises that visuals be placed in such a way that readers do not have to flip pages backward and forward to see the image while reading the information related to it. This will then avoid confusion and annoyance.

Secondly, the content-related pattern looks at how the image and text link together to form the message (Stöckl, 2009: 215). The image and text can either assist one another in elaborating and explaining a message or bring about a division by providing contrasting information. The latter is often found when one element dominates the other or both elements are found to be too vague (Stöckl, 2009: 216). An example would be providing too much information accompanied with a basic unmarked image or providing too little information with a non-explanatory image. Stöckl

(2009) analysed various advertisements and found that technical writers lose the attention and interest of readers and viewers because of the lack of co-ordination between image and text.

The final type, Stöckl (2009) adds, is the humorous or rhetorical logic. Stöckl (2009: 219) explains that this playful type “simply uses the potential for coincidental, allusive and meta-communicative connections between the text and visuals.” For example in an Audi A4 vehicle advertisement, Stöckl (2009: 219) found that “the image literalized the verbal message and the language-image link provided a humorous semiotic game”. Viewers of the advertisement did not take offense over the images of farm animals displayed and associated with the Audi brand, but understood the reasoning and logic behind it - that horses referred to horsepower and that cows have a relation to the leather interior in the vehicle (Stöckl, 2009: 219).

In one multimodal study of technical documents using Stöckl’s text-image relations, Mäkynen (2012) analysed two user manuals, a Nokia Lumia 800 manual and a user manual of Gemini. The manuals differed in their display and use of images and text. Each manual produced different results. The Lumia 800 manual focused on expressing “spatial relationships, reinforcing verbal descriptions and orienting the user of the manual” (2012: 75). The Lumia 800 manual was made up of sets of instructions explaining the functions of a cellphone. According to Mäkynen (2012: 75), although images are often better used to explain a product, rather than text, the images used in the Lumia 800 manual were not only used to support the text but also to add something to it. Text and image therefore assisted each other to get the instructions across to the reader.

On the other hand, the Gemini manual used images to “clarify abstract content by describing the structure of the software” (2012: 75). In this manual, the text was the dominant mode which worked better for describing and explaining concepts, whereas the images just played a supportive role to the text (2012: 75). According to Mäkynen (2012: 75), the images and text used in the Gemini manual were most useful when the reader had to locate something, as they “described the structure of the software and helped verify that the user kept up with the instructions.” Mäkynen (2012) concludes that this helped users build a mental model of the programme (2012: 76).

## 2.6 Sequencing of information and sentence structure

The CPA explicitly mentions “*sentence structure*” in paragraph “c” of Section 22(2) as an issue in product information. The relationship between sentence structure, issues of style (also mentioned in paragraph ‘b’ of Section 22(2)) and understanding of information in technical instructions or manuals has been addressed from a number of perspectives in the literature.

In the context of user documents, Woolever (1999) makes a number of points relevant to sentence structure and shows how sentence structure can affect the understanding of information in technical documents. She states that technical writing must be (1) transparent, so that instructions do not obstruct the user from accomplishing a task; (2) task-oriented, so that the organisation of information follows the order of tasks as they should be performed and, lastly, technical writing should be (3) clearly formatted so that the document’s design hastens the task that should be carried out by the user (Woolever, 1999: 238).

One way in which a user may be obstructed from accomplishing a task is when the user is not directly addressed. According to Woolever (1999: 94), “prose is more direct when naming the persons or things that are the focus of each sentence.” In so doing, the writer places emphasis on who needs to do what and what the outcomes will be. Shäffner and Wiesemann (2001: 51) observe that “a characteristic feature of user manuals is that the instructions themselves are typically expressed by imperative structures in English.” They state that imperative structures seem to be more frequent if the text addresses a population of readers who want to use the product, whereas infinitive structures are more common if the text addresses experts of a product, for example, those who are responsible for installing the product to be used by readers.

The concept of task-oriented writing mentioned by Woolever (1999: 238) evokes the construct of iconicity in syntax. Antia (2014) looks at iconicity and word order and discusses these with regard to technical documentation. Iconicity refers to signs resembling an object – its referent. According to Antia (2014: 509, citing Givon, 1985: 189) “the principle of iconicity in syntax claims that grammatical structure is motivated by the structure of extralinguistic reality”, and that all “other things being equal, a coded experience is easier to store, retrieve and communicate if the code is maximally isomorphic to the experience” (Givon, 1985: 189). In other words, “the

more a sentence encodes some reality according to the logic of the reality (e.g. stages of occurrence), the easier it is for the idea in the sentence to be processed (e.g. understood, recalled, or executed) (Antia, 2014: 509).

Antia illustrates the application of iconicity to technical documentation by showing the different effects of an iconic versus non-iconic sentence in an airline safety announcement:

- (1) Inflate the vest on leaving the aircraft.
- (2) On leaving the aircraft, inflate the vest.

When looking at the above sentences, at first glance both seem appropriate to use. However, if we analyse the sentences closely, we find that their action outcomes are different. If the vests are already inflated while one is in the aircraft on the way out, as the fronting of “inflate” in (1) suggests, it would cause havoc and congestion. If the vests were inflated only when one was on the verge of leaving/jumping from the aircraft as in (2), the passengers would have a higher chance of escape and without any form of struggle.

Another relevant syntactic-rhetorical issue is called frontloading, and this has to do with deductive organisation of a complex sentence. According to Woolever (1999: 69), a writer needs to realise that s/he is leading readers on a journey throughout the document and is therefore required to guide them. Woolever (1999: 70) refers to this kind of organising as frontloading and it involves setting the reader’s expectations. The following examples are from a manual for an automatic washing machine in which the “frontloaders” are highlighted:

- *“To cancel Delay Start, press the (On/Off) button, then turn the washing machine on again”, and*
- *“To connect the water supply hose: (1) Take the L-shaped arm fitting for the cold water supply hose and connect to the cold water supply intake on the back of the machine. Tighten by hand.”*

[http://laundry.manualsonline.com/manuals/mfg/samsung/b1013j\\_1.html?idRes=161956](http://laundry.manualsonline.com/manuals/mfg/samsung/b1013j_1.html?idRes=161956)

2)



In these examples, the user is first told the goal of the actions to be performed, rather than the instructions being stated first and the goal last.

An excerpt (Figures 1 and 2 below) from a manual of an automatic washing machine provides instructions in the form of condensed information by using a numbering system, bullets and headings to make reading and the processing of information easier for the reader:



Figure 1: Examples of frontloading instructions and neatly condensed information from an automatic washing machine manual<sup>3</sup>.

In figure 1, frontloading is illustrated by the subtitles “Washing for the first time” and “Putting detergent in the washing machine”. The numbered stages also illustrate neatly condensed information. We see a more or less similar pattern in figure 2.

<sup>3</sup> Excerpts from a manual of an automatic washing machine  
[http://laundry.manualsonline.com/manuals/mfg/samsung/b1013j\\_1.html?idRes=1619562](http://laundry.manualsonline.com/manuals/mfg/samsung/b1013j_1.html?idRes=1619562)

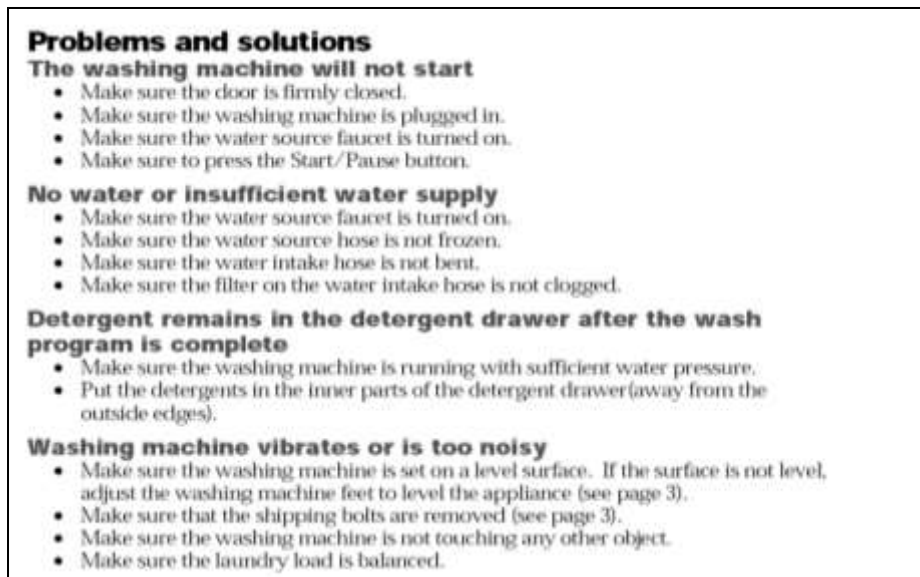

**Figure 2: Examples of frontloading instructions and neatly condensed information from an automatic washing machine manual<sup>4</sup>.**

Unlike in figure 1, where the frontloading is related to goals, in figure 2 the subtitles relate to problem types, and the bulleted points list possible actions to take to address the corresponding problem. Woolever (1999: 201) advises that in order to make information and long descriptions look more readable, writers should “use headings, numbers and bullets to differentiate parts, steps and other divisions of information.” This condenses the information and makes the text easier to read and follow.

Let’s consider a final dimension of the sequencing of information. Kintsch and Vipond (1979) stress that readers better process text when information is established in a hierarchy of topics; when chunks of information are grouped into meaningful units; and when consistency of topics is maintained so that readers can establish thematic continuity. The notion of a hierarchy of topics addresses dependencies of themes. It implies for instance that topic X, in respect of an earlier occurring action, needs to be presented before topic Y, related to an action that occurs later. The notion also involves the establishment of intertextual ties and scaffolding - in the sense that the building blocks for certain operations are provided before the operations are encountered. For instance, it would seem inappropriate to read an instruction on assembling a device when the parts of the device have not previously been presented.

<sup>4</sup> Excerpts from a manual of an automatic washing machine  
[http://laundry.manualsonline.com/manuals/mfg/samsung/b1013j\\_1.html?idRes=1619562](http://laundry.manualsonline.com/manuals/mfg/samsung/b1013j_1.html?idRes=1619562)

## 2.7 Standards of Textuality

de Beaugrande and Dressler's (1981) framework enables us to address broader issues underpinning the status of manuals as texts that are intended to be understood. Section 22(2) of the CPA requires the text of notices to be presented in such a way that a user can "*be expected to understand the content, significance and import*" of such notices.

de Beaugrande and Dressler (1981: 3) identify seven basic standards that justify a text and make it a "communicative occurrence." These standards are called standards of textuality. They make a communicative occurrence qualify as a text, which is distinguished from a non-text. These standards are *cohesion, coherence, intentionality, acceptability, informativity, situationality, and intertextuality* (de Beaugrande & Dressler, 1981: 3-4).

Understanding can be impeded by a lack of cohesion. *Cohesion* is the first standard of textuality identified by de Beaugrande and Dressler (1981) and it refers to components of the text that are connected within a sequence according to grammatical conventions. According to Halliday and Hasan (1989: 489), "cohesion enables one part of a text to function as the context for another." Looking at the pronoun "*them*" in the following sentence is an example of how cohesion is expressed: "Dice the onions, peppers and carrots. Add *them* to the stew." The pronoun "*them*" is dependent on what was mentioned and referred to in the previous sentence. The first sentence therefore creates a context for what is to follow.

This leads to Abushihab's (2010: 138) understanding of cohesion which is described as "the elements in a text that must be tied to each other in such a way as to signal a continuously developing theme within a sentence." These elements include substitution, ellipsis, conjunctions and lexical repetition (Halliday & Hasan, 1976: 88) and they link sentences and clauses, thereby turning separate expressions into a unified whole by developing relationships between those separate expressions (Shahriar & Pathan, 2012: 374).

*Coherence* is the second standard identified by de Beaugrande and Dressler (1981). Whereas cohesion has to do with the formal links, coherence has to do with the semantic links. According to Halliday and Hasan (1989: 48), "a text is characterised by coherence when it hangs together."

Texts have to set and maintain the same idea or message and not confuse the reader by mismatched ideas resulting in a senseless text. There has to be a form of relation and closeness between the sentences and texts.

The third standard of textuality is what de Beaugrande and Dressler (1981: 7) call *intentionality*. It refers to whether, and how well, the intention of the text producer comes through, given the cohesion and coherence of the utterance. *Acceptability* is said to be the fourth standard and it refers to the reader's attitude that the message or text is useful or relevant. No matter how well written a text is, if it is not accepted (e.g. when product users are said not to bother consulting manuals), it loses its status as a communicative occurrence.

The fifth standard, *informativity*, concerns the extent to which information is known or unknown to the reader (de Beaugrande & Dressler, 1981: 9). It deals with the relationship within a text of information presumed to be known and new information. In a manual, what is assumed to be known can actually be an arguable issue. A text or manual that contains too much known information may not sustain the interest of the reader, just like one that contains too much new and challenging information. Since a manual has to document a new product, care has to be taken to carefully plan information so that what is new information at one point is presented in such a way that it can easily become known information at another point.

de Beaugrande and Dressler (1981: 9) refer to the sixth standard as *situationality* and define it as “a standard which concerns the factors which make a text relevant to a situation of occurrence.” Situationality concerns the context which makes a text relevant. Without an appropriate context, a text or part of a text can become difficult to understand or easily misunderstood. In technical writing, the principle of situationality can be seen in the context-sensitive help in the online documentation built into certain software packages. It can also be seen as what is referred to as “goal statements” (Woolever, 1999: 242) in frontloaded instructions, which tell users why they are to perform a series of steps.

The last standard is *intertextuality*. As de Beaugrande and Dressler (1981: 10) use this term, it has to do with “the factors which make the utilization of one text dependent upon knowledge of

one or more previously encountered texts”. As seen in the section on genre, familiarity with other texts of the same class makes it easy to use and to produce new texts of the same genre. Manuals are structured and written the way they are because of previous examples. The same principle applies to consumers; they know what a manual looks like and what is expected to be in it because of previous experiences with information leaflets and manuals.

## **SUMMARY**

South Africa’s Consumer Protection Act (CPA) is an in-depth and comprehensive document which, as the preceding sections show, has provided the basis for the theoretical constructs reviewed in this chapter. When analysing the two manuals in Chapter 4, these constructs will be applied to determine if the manuals adhere to the standards outlined in the CPA. In the following chapter we will look at the methods used to collect the data for this study and also how these methods assist in producing the relevant information.



## CHAPTER 3

### RESEARCH METHODOLOGY

#### 3.0 Research Design and Methodology

As previously stated in section 1.2, the study analysed two user manuals to determine the extent to which they were understood and could be used to carry out specific tasks. The data was made up of both qualitative and quantitative research. A qualitative research method includes observations, interviews, focus group discussions, ethnography or field notes; it allows for the gathering of rich, unique and in-depth information from research participants in the form of words, actions and analysis (Henning, van Rensburg & Smit, 2004). According to Babbie and Mouton (2001: 270), qualitative research is aimed at studying human actions from the perspective of the social actors themselves and the primary goal is to describe, understand and interpret human behaviour.

According to Struwig and Stead (2001: 4) quantitative research represents large representative samples and fairly structured data collection procedures. The primary goal of quantitative research is to test hypotheses and the relevant data may be collected through questionnaires and some form of structured observation (Struwig & Stead, 2001: 4).

This study used both qualitative and quantitative methods. The qualitative method enabled me to analyse the manuals and to have selected participants use the blenders. It also enabled me to develop hypotheses which was then tested quantitatively through the administration of questionnaires to elicit participants' views, preferences and their understanding in respect of the manuals.

#### 3.1 The Manuals to Be Analysed

Two user manuals for two brands of household food grinders/blenders marketed in South Africa have been selected for the study. The manuals were associated, respectively, with the Logik 2-in-1 Blender and Grinder (Model No.: LBG-1831) and the Ottimo Stand Blender (Model No.: YD-FM-805). The choice of product blenders was based on a combination of the following criteria:

- Manuals which are at the most 10 pages long, so as to limit to a minimum the work done by participants.
- Manuals associated with products which the researcher possesses or can easily afford to purchase for the study.
- Manuals of products that are not entirely strange to would-be participants in terms of the product functions (the products however still have functionalities which cannot be carried out intuitively and require some guidance).
- Manuals of products that are used across many socioeconomic classes and by consumers of all ages.

The Logik 2-in-1 Blender and Grinder (Model No.: LBG-1831) is manufactured by Dixons Retail, a European manufacturer of consumer electronics, personal computers, domestic appliances and so on (<http://www.dixonsretail.com/dixons/en/aboutus/whoweare>). The manual accompanying the blender is a very basic instruction manual of an A5 size containing information in a small, yet readable font size. This manual is a six-page document (including the cover page), and content is separated and distinguished by one-word headings and short, bulleted paragraphs and sentences.

UNIVERSITY of the  
WESTERN CAPE

The Logik manual displays two images: one photographic image of the product on the cover page together with the model number and on page two of the manual, the second image which is an exploded view of only the blender product. Page one of the manual displays important information regarding safety before using the product; information regarding the blender and grinder (with the second image displayed); a general description of the various parts on page three; a “how to” information section; safety tips; a bulleted piece on what ingredients to use in the mill and also advisable quantities and lastly, storage and cleaning information on pages four and five.

The Ottimo product is manufactured by Yingda Holdings Limited, a Chinese manufacturer of home appliances (<http://www.cccme.org.cn/shop/cccme10366/index.aspx>). The blender is accompanied by one instruction manual, totalling 24 pages of which 6 pages are dedicated to each of the following languages – English, Portuguese and French. The manual is printed in an

A5 format containing content in a small, yet readable font. It displays on the front cover the brand name “Ottimo” positioned on top of the page and just below it, the product name, a photographic image of the product in the centre, followed by a product model number and manufacturing information.

Also on the front cover of the manual is a request to the consumer to only use the product indoors and to save and read the instruction manual. On pages one and two, the manufacturer introduces the user to the product and congratulates the user on his/her purchase of the kitchen blender. Thereafter follows all safeguard information and basic instructions, as well as an exploded view of the blender together with a description of the various parts at the bottom of page two.

Following these are blender assembly instructions as well as visuals for the user and also “how to” instructions together with blending tips. The Ottimo manual provides basic steps to maintaining and cleaning the blender and a disposal tip. Lastly, a warranty section is included with provision for important information for the user to complete in the case of claims from the user to the manufacturer.

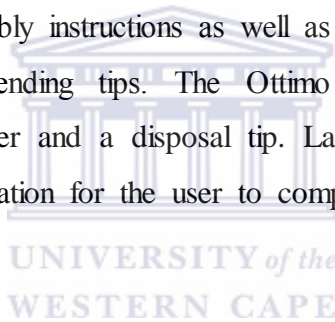

A few obvious comparisons between the Logik manual and the Ottimo manual are as follows:

- The Logik manual is printed in English only, whereas the Ottimo manual has made provision for English, Portuguese and French speaking users, each in separate sections of the manual. Each language has six dedicated pages.
- The Logik manual begins (on page one) with important safety information in bulleted sentences whereas on the first page the Ottimo instruction manual congratulates the user, introduces the user to the kitchen blender and provides a page of important safety information in short paragraphs and sentences.
- The Logik manual provides an exploded view of the product on one page and the descriptions of the parts on the following page. The Ottimo manual provides an exploded view of the product and the descriptions of the parts on the same page.
- The Logik manual does not provide a section with warranty information whereas the Ottimo manual has a dedicated section provided for warranty.



Neither of the manuals provide website links for one to access any further information regarding the product or brand. However, both brands are originally non-South African products but the companies that market them are fully incorporated in South Africa. Since these brands and products are marketed in South Africa, they need to comply with the rules and regulations as stipulated in the CPA of South Africa.

### **3.2 Research Design**

It is common for evaluations of user manuals to combine comprehension tasks with observations of study participants using the manual to actually perform tasks on the product (Woolever, 1999: 247; Ummelen, 1997: 32-37). Whereas semiotic analysis and questionnaires are suited for the comprehension tasks, usability analysis is relevant for observing and studying the performance of tasks on the product. Consistent with this tradition, the study had the following phases: in the first phase, the researcher did a multimodal analysis of the manuals, guided by the theoretical constructs reviewed in the previous chapter (terminology, multimodality, sentence structure, and so on). The purpose of this in-depth analysis was to generate ideas for other phases of the research such as the development of a questionnaire and the design of specific tasks. The analysis was expected to reveal the strong and weak points of the manuals from the standpoint of theoretical constructs presented in Chapter 2.

In a second phase, 46 typical or potential users of household blenders (not necessarily the particular brands documented in the manuals) were each presented with the manuals and asked to answer a range of objective questions and “attitudinal” (Woolever, 1999: 248) questions on the contents of the manuals. These questions consisted of open-ended questions, equally involving possible blender users having to reason through situations and to offer explanations. The items in the questionnaire were derived from findings in the analysis carried out in the first phase.

The questionnaire was first piloted to ensure validity (the trustworthiness of the findings) and reliability (the extent to which the test scores are accurate, consistent and stable) (Struwig & Stead, 2001: 19; 130). Only thereafter was the questionnaire administered. Descriptive statistics were used to analyse the more objective questions which required, for instance, the identification

of parts or eliciting understanding of certain instructions, while thematic content analysis was used to analyse the data on the respondents' feelings towards aspects of the manuals.

In a third phase, 3 additional study participants were independently requested to use the manuals to assemble the kitchen blender. This phase is what Woolever (1999: 248) refers to as "informal observations and interviews". These observations and interviews "yield more qualitative than quantitative results. By watching people use the documentation and then talking to them about it, one gains perspectives not provided by other types of tests".

The analysis of these data involved relating observations (of ease or difficulty in the performance of tasks) to the two previous data sets; the results of the multimodal analysis and the results of the questionnaires. The data from these various sources provided the basis for addressing the objectives of this research as stated previously.

### **3.3 Participating Respondents**

Data was collected from 46 randomly selected participants, males and females, from the ages of 18 to 60+ years. Participants were recruited through direct requests. The participants ideally resided in the Northern and Southern Suburbs as well as the Cape Flats areas of Cape Town, as it was easier for the researcher to travel to participants' residences or have participants travel to the researcher's home to conduct the study.

Participants were required to complete a questionnaire (in English) related to either the Ottimo manual or the Logik manual. A further 3 participants were asked to assemble the kitchen blender whilst being video-recorded and observed. The data collected from these two processes were processed and analysed accordingly.

Participants were allowed to ask questions at any stage during the process if they were confused about something. It was also the participant's right to withdraw from the study at any stage of the process if he/she felt the need to.

### 3.4 Data Collection Instruments

The data collection instruments required for the study were as follows:

- Questionnaires, one each for the Ottimo and Logik manuals (see Appendices 3 and 4). These questionnaires were intended to help collect data for determining how well the manuals were understood by the participants and their feelings towards aspects of the information in the manuals. These questionnaires were developed based on the manual analysis conducted by the researcher beforehand. There were questions relating to the participant's background, followed by questions based on the manual. These questionnaires were piloted beforehand by 6 people of different genders and age groups, so as to make sure that the questionnaires were suited for all age groups and that they were constructed in a clear manner and that the instructions were easily understood.
- A video camera was used to record 3 participants as they attempted to assemble the blender after reading the assigned manuals. These video recordings took place at either the researcher's home or at the participant's residence, at a time most convenient to the participant. As per the initial idea, 3 video recordings were done of participants assembling the kitchen blender with no further instruction from the researcher, to examine whether or not the participant would make use of the manual accompanying the kitchen blender, whether or not the manual did in fact assist the participant in assembling the blender, or whether it was all done based on previous experience or common knowledge.

### 3.5 Data Analysis

I drew on the theoretical constructs presented in Chapter 2 to analyse the data in order to address the various objectives of the research. In attending to the first and second objectives, I analysed participants' responses in the questionnaires that were administered to them. I looked at the data collected from the questionnaires in which specific questions attended to the issue of understanding what was expected from the person reading the manual, whether participants were able to make sense of what was asked and whether the required action was achieved.

Data collected from the video recordings addressed the third objective. The video recordings enabled me to see whether or not participants (potential owners) were able to carry out specific tasks using the manual.

To address the fourth objective, I examined ways of improving the manuals in the light of findings from previous sections. I made recommendations for optimising the manuals so as to achieve a number of goals emphasised by the participants in their questionnaire results, and with an eye on the requirements in the CPA.

### **3.6 Limitations of the Study**

Possible shortcomings of this study stemmed from the limited number of blenders and blender manuals (two), the number of participants (46), the areas from which participants were recruited, and the English language in which respondents had to respond. For financial reasons and to cut down on the tasks volunteers were performing, I had to limit myself to two blenders and blender manuals. Given the fairly demanding nature of participants' involvement and the fact they were not going to be paid, I had to restrict my recruitment to areas in which I and my friends, or work colleagues, had the most personal contacts.

Although English may have been a problem for a small number of respondents (who in such cases were helped), using Afrikaans would have been an even greater problem, as many respondents would not have been able to read the language or understand the technical information in the questionnaires. In spite of these limitations, it is expected that the study will still give a tangible sense of the semiotic quality of the manuals associated with both blenders and of the ability of users to operate the blenders on the basis of the manuals.

### **3.7 Ethical Considerations**

Qualitative research emphasises that the researcher should respect the participant(s) and that a manifestation of this should be reflected in the methodology of the study (Creswell, 2007). Thus, the participants were required to give their informed consent. Participation was strictly voluntary and confidential. The participants were informed of the nature and purpose of the study, and that

there would be no harmful procedures involved. The participants were also given the opportunity to ask questions before, during and after the experiments.

As some of the participants were video recorded, they were assured of confidentiality and anonymity in the reporting of the research. Participants were informed that they would not be referred to in the dissertation by their names but by numbers. The participants were also informed that their participation was entirely voluntary and that they had the right to withdraw from the process at any stage of the study. To protect their identity, these recordings were only done from the bust downwards, not including the participants' face. The consent forms and information sheets are attached as Appendices 1 and 2.



## CHAPTER 4

### THEORETICAL ANALYSIS OF THE PRODUCT MANUALS

#### 4.0 Introduction

To respond to the first objective on how the manuals comply with the provisions of the CPA, this chapter will apply theoretical constructs reviewed in Chapter 2 (themselves related directly to the CPA) to evaluate the Logik and Ottimo manuals.

#### 4.1 Logik Manual Observations

For no particular reason, an analysis of the Logik manual will be performed first. This is a 2-in-1 blender and grinder product, manufactured in Europe but marketed in South Africa. The manual is an A5-size document consisting of six pages (including the cover page), and a compilation of instructions in a small, yet readable font. The Logik manual is presented in a typical manual format and is written and compiled for English language readers only.

The cover page of the Logik manual provides the reader with a large registered company name and slogan across the top section of the page which reads “LOGIK. MAKING SENSE”. This is the main element of the document which distinguishes it from its competitors. Below the company name is the product description and model number which reads as “2-in-1 Blender with Grinder. Model No.: LBG-1831”. This provides the reader with insight as to what type of product it is and its unique model code.

What follows on the cover page of the Logik manual is a 3-dimensional image of the blender and grinder (refer to figure 3), placed in the middle of the front page and shows the consumer what the completed assembled product looks like.

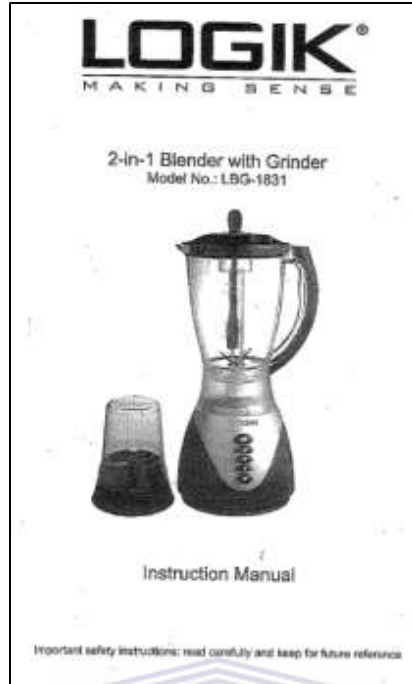

**Figure 3: Cover page of the Logik 2-in-1 Blender with Grinder manual.**

Below the image are the words “Instruction Manual” and lastly, a brief sentence summing up the front page which reads as follows, “Important safety instructions: read carefully and keep for future reference.”

#### **4.1.1 Multimodal aspects of the Logik manual**

As may be recalled, the 6-page Logik manual has two images: the first image which introduces the user to the product on the cover page of the manual and the exploded 3-dimensional view of the kitchen blender, detailing each product part, which is found on the second page of the manual. There are a number of critical points that can be made about the positioning of images in the manual, how they are labelled, their sizes and the way they complement or overpower texts. Let us begin with the positioning of images.

As can be seen in figure 4, the description above the image reads “2-in-1 Blender with Grinder”.

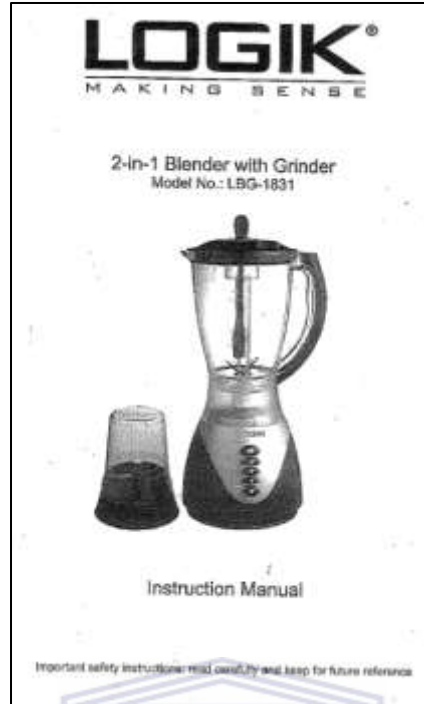

**Figure 4: The first image displayed on the cover page of the Logik manual.**

In figure 4, the sequence of images, however, is the grinder and blender. So, the text does not coincide with the arrangement of images. In Western cultures, people are taught to read from left to right, as opposed to Eastern cultures, where people read from right to left. The word “Blender”, which appears first in the product description above the images, is positionally paired or matched (in the images) with what is in actual fact the grinder (the smaller of the two devices), and the word “Grinder” is in terms of position paired with what is actually the blender (the bigger device).

This arrangement violates one of Schriver’s (1997) image-text relationships, namely complementarity. Although the image is translated in the product description/caption, it conveys the incorrect perception to the reader. Such a mix-up on the cover page of the product manual can create image problems for the product, because as Schoff and Robinson (1991: 3) point out, a poorly designed manual may cast doubt on the quality of the product itself.

The second place where an image is found in the manual is on the bottom half of page 2. Refer to figure 5.



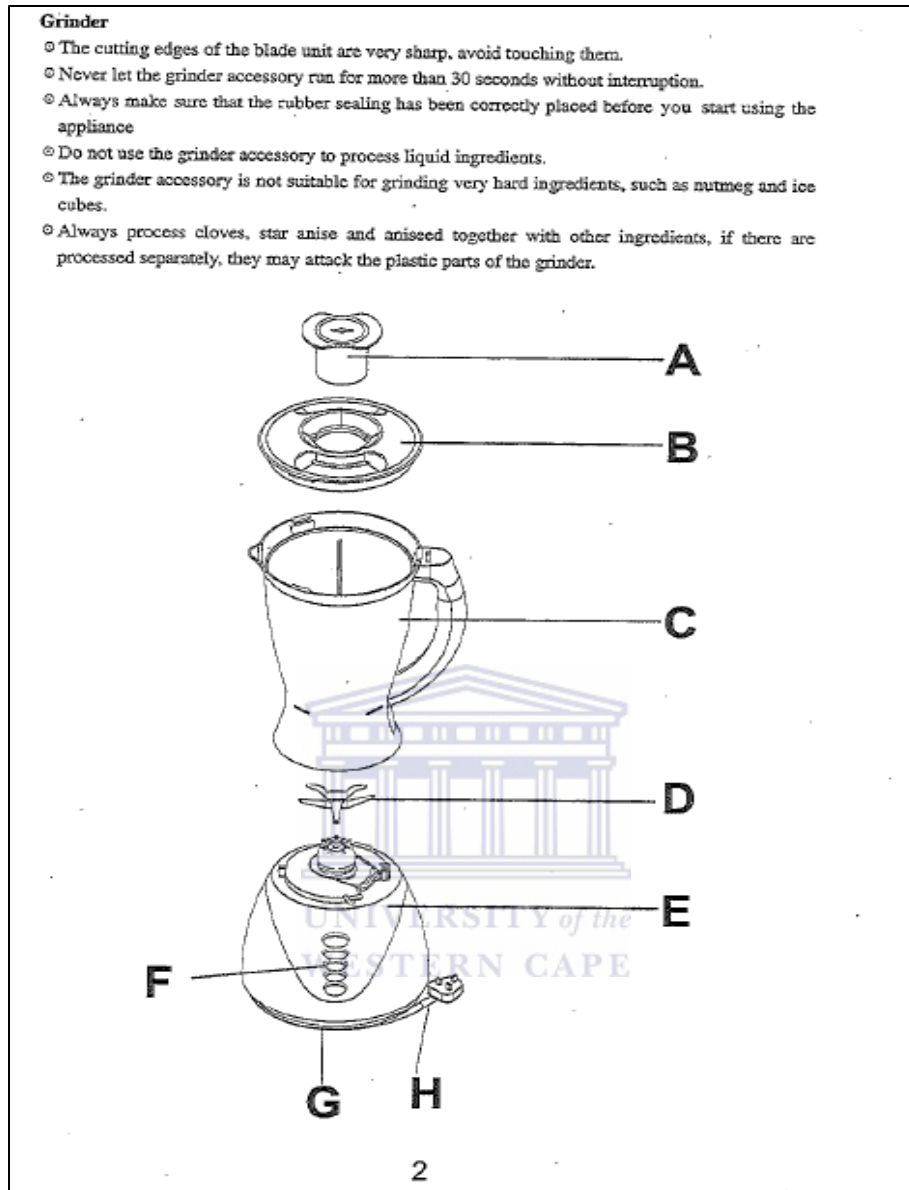

**Figure 5: Exploded view of image on the second page of the Logik manual.**

In figure 5 we see an exploded, 3-dimensional view of the blender. There are several issues in this figure (which is the entirety of the second page of the manual). Firstly, the image can be seen as not having been introduced or as having been wrongly introduced. The top of page 2 reads “Grinder”. If one were really not familiar with the kitchen blender, the sequence of wording on the cover page of the manual, as previously mentioned, and what we see on the second page (figure 5) would give the impression that the bigger product is indeed the grinder and the smaller product the blender.

The fourth bullet in figure 5, “Do not use the grinder accessory to process liquid ingredients” combined with the knowledge that the image shown on page 2 is the one used for blending liquid and dry ingredients (and not the smaller product), tells us that the title “Grinder” and the associated text cannot be referring to the image produced on page 2. Therefore the image should have been introduced beforehand, possibly before the “Blender” heading and instructions on page 1 (see figure 6). This was not the case and violates the principle enunciated by Woolever. Woolever (1999: 137) states that, “when placing graphics in a text, the graphic should be introduced to the reader beforehand and should not overpower the text, but complement it.”

The second issue in figure 5 is that there is no description of the parts labelled A-H. The product descriptions for codes A-H are only given on the following page (page 3). It would be recalled that Stöckl’s (2009: 218) spatial-syntax relationship concerns the way in which the image and text are designed on a page, and how having these two elements separated, results in paging back and forth. For the reader of the Logik manual to know what each of codes A–H stands for, s/he has to constantly page over to page 3, as seen can be seen in figure 6.

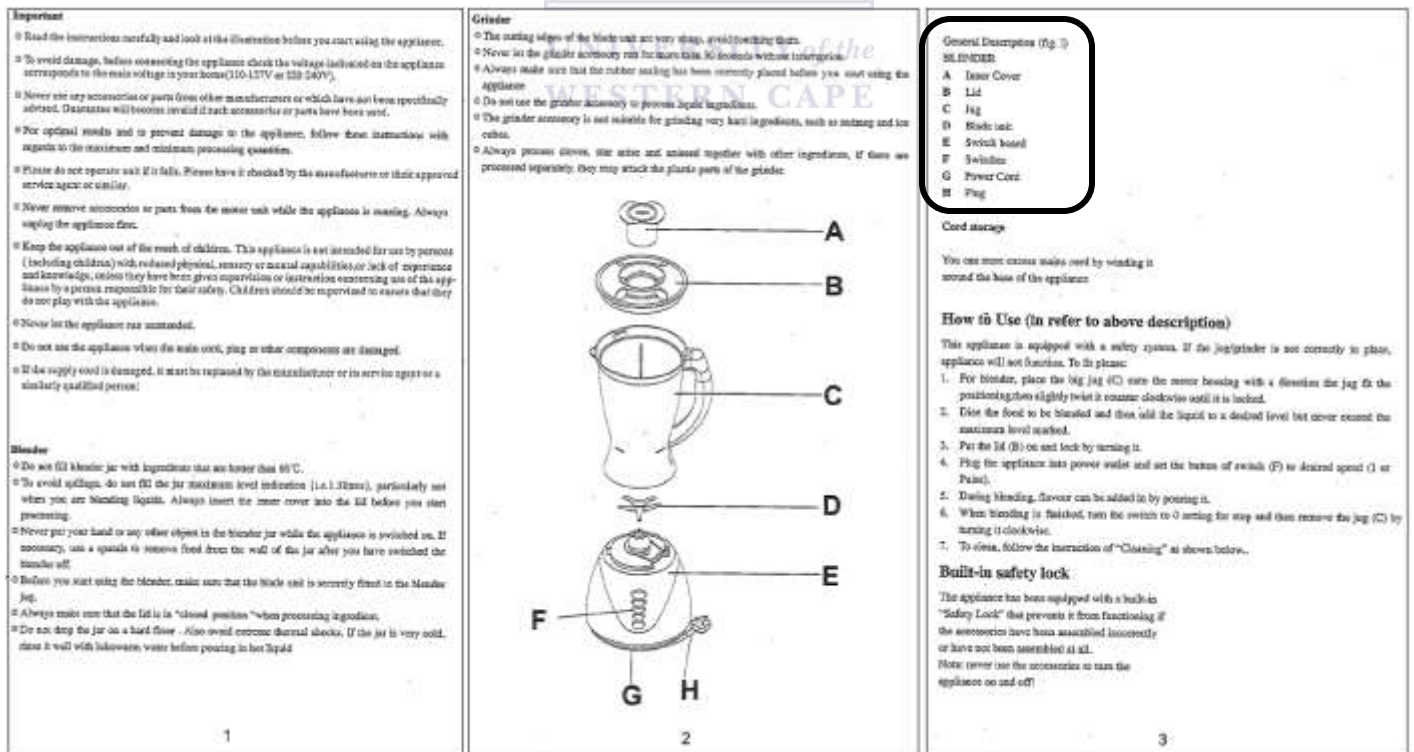

Figure 6: A display of the Logik manual pages indicating a violation of the spatial-syntax relationship.

In figure 6, which is a representation of pages 1, 2 and 3 of the Logik manual, we find that at the bottom of page 1 the reader is introduced to a section describing the “Blender” product. It refers to its various parts, namely, the blender jar, lid, inner cover and the blade unit. However, a visual representation of these parts are only given on page 2. As stated earlier, the exploded and labelled image on page 2 is not very informative because the codes A-H are only introduced on page 3, resulting in the user having to consult page 3.

As will be seen later in the section dedicated to terminology within the Logik manual, the part descriptions as mentioned on page 1 under the blender heading and the part descriptions as listed on page 3 sometimes use different terms to refer to a given part of the product. This can only add to an already unpleasant user experience.

Furthermore to what was examined above, in figure 6 we also find that there is poor utilisation of page space. There is a lot of wasted space on each side of the image (on page 2 of the manual) which could have been better utilised. Had the image been right-aligned or left-aligned, this would have given the writer or designer of the manual ample space to include the product descriptions on the side of the image, resulting in the user not having to page back and forth. Placing the image and the associated text next to each other would also allow synergy between the two elements, which would then achieve better results in getting the message across to the reader of the manual (Woolever, 1999).

To illustrate another aspect of multimodality, that is, the display of information on the page, it is interesting to analyse the cover page of the Logik manual from the standpoint of Kress and Van Leeuwen's concepts of ideal and real positions. It would be recalled that the ideal position is at the top and real position is at the bottom. Kress and Van Leeuwen (2006: 187) explain “real information” as information which is more specific and practical and the “ideal” as more idealised, generalised information. With the brand name "Logik" and the associated tagline "Making Sense" on the top of the cover page of the manual, the user is being encouraged to embrace an ideal product and a brand that supposedly makes a lot of sense. On the other hand, at the bottom of the cover page, the text "Important safety instructions: read carefully and keep for

future reference" is considered real information and information that is vital to the user when he or she prepares to use the product.

#### 4.1.2 The use of terminology and inconsistency in the Logik manual

In the context of user documents, Woolever (1999) states that technical writing must be transparent, so that instructions do not obstruct the user from accomplishing a task. In agreement, Kintsch and Vipond (1979) add that when consistency of topics is maintained, the readers can establish a thematic continuity.

Terminology is used rather inconsistently to describe product parts in the Logik blender. Rogers (2008: 59) writes that "consistency of terminological choice has been seen not only as a characteristic of good technical writing in itself, but also as an advantage of machine translation over human translation." Schmitz (2007: 155) states that "consistency is a prerequisite in texts in order to empower users. The purpose should be to use only one word for one concept and if this is not the case it will leave the user frustrated if several terms are used to describe one item." Backinger and Kingsley (1993: 27) advise manual writers to "use the same term to identify the device and its parts throughout the manual and to avoid synonyms or alternate phrases." They go on further and warn that writers should be clear when writing instructions because many people will not reread something they do not understand (1993: 17).

Figure 7 is an excerpt of the various blender product parts coded A-H.

General Description (fig. 1)	
<b>BLENDER</b>	
<b>A</b>	Inner Cover
<b>B</b>	Lid
<b>C</b>	Jug
<b>D</b>	Blade unit
<b>E</b>	Switch board
<b>F</b>	Switches
<b>G</b>	Power Cord
<b>H</b>	Plug

Figure 7: Product parts as listed on page 3 of the Logik manual.

A reasonable expectation would have been that when these products are later on referred to in the text, the same terms will be used. This is, however, seldom the case. As can be seen in figure 8, several synonymous words such as “blender”, “blender jug”, “jug” and “jar” are used to refer to one specific part of the blender, which is in actual fact labelled as “jug”.

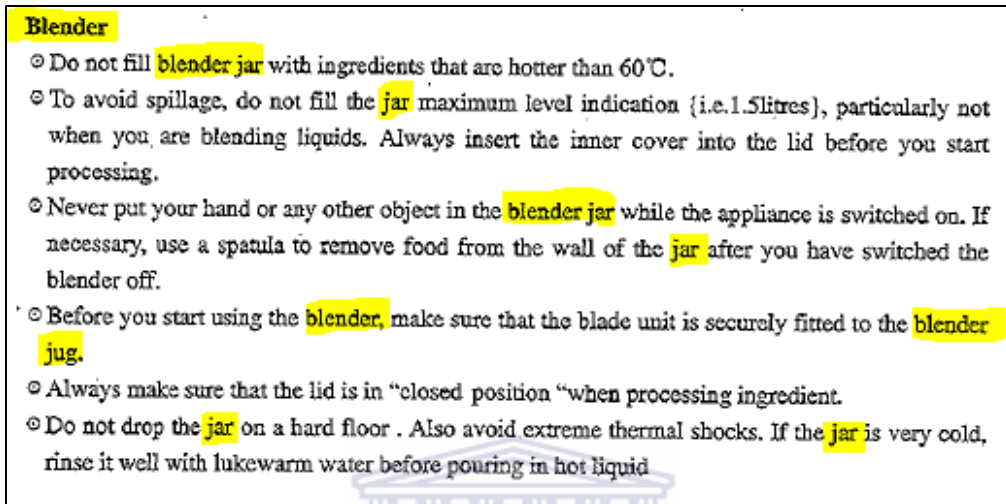

Figure 8: The numerous inconsistent terms for the part labelled as “jug”.

In figure 8, we find that the words “blender jar”, “jar”, “blender” as well as a “blender jug” are used interchangeably throughout the instructions, all referring to one product part - the jug. This inconsistency can be problematic to those users who are not first-language English speakers as they may not know that these synonymous words refer to the same product part.

Let us consider another example. What is marked as the switch board (E) in figure 7, in which the parts are coded A-H, is also referred to as the “motor unit” and “motor housing” throughout the manual. Figure 9 shows examples of these instances.

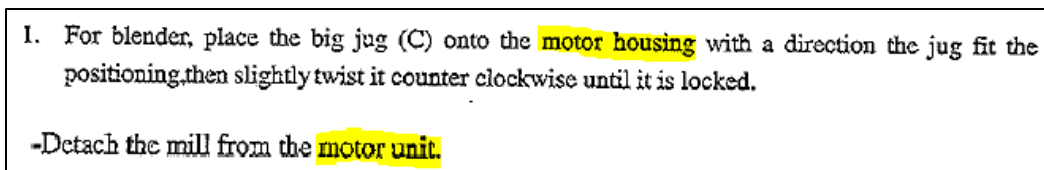

Figure 9: Excerpts of instructions where inconsistent terms are used to refer to a specific product part.

So, not only would some readers have to deal with the challenge of figuring out the relationship between “motor housing” and “motor unit”, they may also need to determine how both of these are related to “switch board”.

In the next example, the inconsistency has to do with “mill” and “grinder”. While so-called native speakers of some varieties of English know these terms to be synonymous, such knowledge may not be readily available to all users of English. Figure 10 presents this challenge.

**What to use the mill for:**

The grinder is suitable for grinding and chopping  
e.g:

Ingredients	Quantities
-peppercorns	25-75g
-sesame seeds	25-75g
-rice, wheat	25-75g
-soy beans	25-75g
-dried peas	25-75g
-coconut flesh	25-75g
-coffee beans	25-75g
-breadcrumbs	one dried slice of bread
-sugar cubes	50g
-nuts(shelled).	25-75g

(Optimal results are achieved if you process the quantities mentioned)

**Figure 10: Inconsistent use of the product name in the Logik manual.**

In figure 10 the reader is introduced to the following heading, “What to use the mill for:” At this stage one may be led to question what a mill is or what the mill refers to. As it may be recalled in figure 7, there is no part labelled or identified as a mill. A sentence follows under the heading which tells the reader the following: “The grinder is suitable for grinding and chopping.” The user is now told what the grinder is used for, but not the mill, as referred to in the heading. The question now remains, what is the mill and what is the grinder? If users are not told by the writer beforehand that these two terms refer to one specific part of the device, commonly known as the grinder, they run the risk of not fully understanding this part of the manual.

Like many of the other scholars reviewed earlier (Schmitz, 2007; Rogers, 2008; Ramaker, 2007), Woolever (1999: 200) reiterates that when describing or summarising technical information, precisely the same terminology needs to be used in all parts of the text. She warns that switching between terms erratically can confuse readers and not leave an impressive thought of the company or brand. Maintaining consistency is also a motivational factor and creates a better understanding between the manual and the reader.

#### 4.1.3 Misleading information in the Logik manual

When reference is made to information that does not exist in the manual (or where it was said to be) or to a feature of the device that does not exist, such information is considered misleading, rather than omitted. The Logik manual has several instances of misleading information. Let us consider some of the instructions in figure 11.

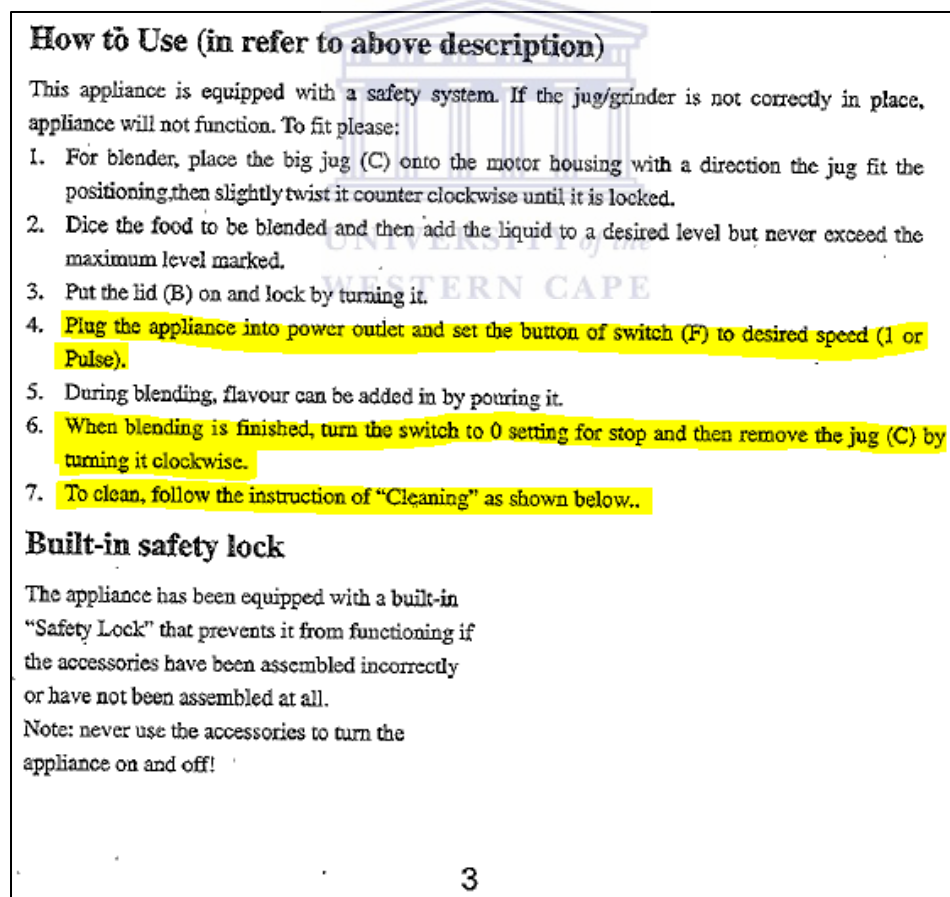

**How to Use (in refer to above description)**

This appliance is equipped with a safety system. If the jug/grinder is not correctly in place, appliance will not function. To fit please:

1. For blender, place the big jug (C) onto the motor housing with a direction the jug fit the positioning, then slightly twist it counter clockwise until it is locked.
2. Dice the food to be blended and then add the liquid to a desired level but never exceed the maximum level marked.
3. Put the lid (B) on and lock by turning it.
4. Plug the appliance into power outlet and set the button of switch (F) to desired speed (1 or Pulse).
5. During blending, flavour can be added in by pouring it.
6. When blending is finished, turn the switch to 0 setting for stop and then remove the jug (C) by turning it clockwise.
7. To clean, follow the instruction of "Cleaning" as shown below..

**Built-in safety lock**

The appliance has been equipped with a built-in "Safety Lock" that prevents it from functioning if the accessories have been assembled incorrectly or have not been assembled at all.

Note: never use the accessories to turn the appliance on and off!

3

Figure 11: Examples of misleading information.

The fourth instruction in figure 11 relates to the speed functions of the kitchen blender. The instruction tells the user to do the following:

4. “Plug the appliance into power outlet and set the button of switch (F) to desired speed (1 or **Pulse**).”

The instruction tells the user to adjust the speed of the kitchen blender to a desired speed, and suggests “1 or Pulse” as speed options. See figure 12 which shows the available speed buttons.



**Figure 12: The device showing the various speed options on the switch board.**

While there is a position 1, there is no “Pulse” blending option on the switch board. A user might wonder if the “Pulse” position is found in other models. S/he may also wonder whether the “M” blending option is what was intended. On page 4 of the manual, the situation is further complicated on where position M is made to appear both identical to and different from Pulse. On page 4 we read:



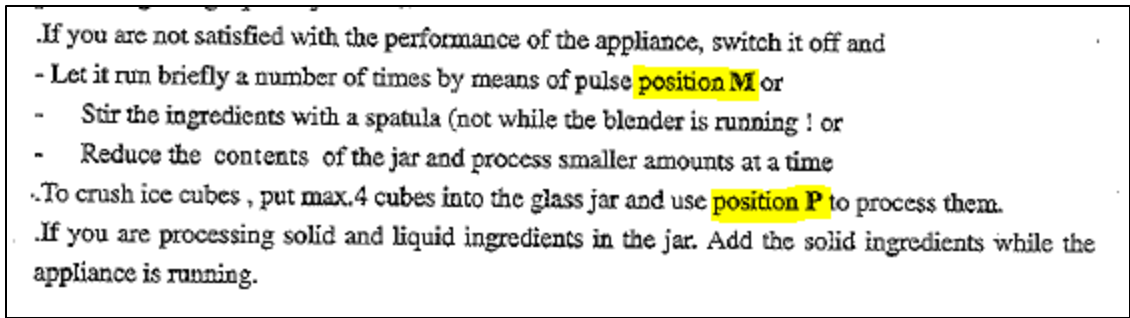

Figure 13: Instructions referring to positions M and P.

While this example may be seen as only a slight irritation for the user, perhaps the next examples have more serious effects. Instruction 6, as previously seen in figure 11, refers to what the user should do once blending is done. The instruction reads as follows:

6. *“When blending is finished, **turn the switch** to 0 setting for stop and then remove the jug (C) by turning it clockwise.”*

The reader cannot “turn the switch” on the switch board as there are only buttons that need to be pushed in order to start and stop the kitchen blender (refer to figure 12 for the exploded view of the kitchen blender). What the writer probably intended to say was that the user should push – instead of turn - the zero button setting to stop the blender processing.

The last instruction under the “How to Use” heading instructs the user to do the following:

7. *“To clean, follow the instruction of “Cleaning” as shown below...”*

However, the text “shown below” (see figure 11) has nothing to do with cleaning instructions. It rather relates to the built-in safety lock. It is only two pages later (on page 5 of the manual) that the actual cleaning instructions are found.

Let us consider another example. In figure 14, which is the general description of the product blender parts, the writer refers to a figure.

General Description (fig. 1)	
<b>BLENDER</b>	
<b>A</b>	Inner Cover
<b>B</b>	Lid
<b>C</b>	Jug
<b>D</b>	Blade unit
<b>E</b>	Switch board
<b>F</b>	Switches
<b>G</b>	Power Cord
<b>H</b>	Plug

Figure 14: Product parts as listed on page 3 of the Logik manual with a reference made to a figure 1.

In figure 14, the writer makes reference to a “fig.1”, yet there is no such image marked in the manual. In actual fact, there are only two images throughout the entire manual - the cover image and the exploded view image on page 2 - which is not marked. Information is presented to the user which does not exist in the manual and misleads the user into believing that there is such a labelled figure. We find a similar situation in figure 15.

**Storage and sprinkling facilities**

After you have processed the ingredients, you can unscrew the mill from the appliance.  
 If you remove the blade unit and replace it with the lid (fig.16).you can store the ingredients, for insurance in the refrigerator. You can also sprinkle the ingredient onto a dish via the reclosable sprinkling hole in the lid handy for on the table!

Figure 15: Information referring to a “fig.16” as well as information relating to “storage”.

In figure 15, the writer of the manual makes reference to a “fig.16”, which does not exist in the manual. This misleads the user into thinking that there is such a figure to which s/he needs to refer to in order to understand the instruction better.

Also, the heading of the text in figure 15 seems to convey to the user that the information to follow relates to storage of the product and its parts. This is further discussed in section 4.1.4.

#### 4.1.4 Grammatical errors and problems of word choice in the Logik manual

Errors of grammar can have the effect that readers of the manual spend more time than would otherwise have been necessary to understand instructions, or they simply skip such difficult to understand instructions. Like issues of word choice, errors of grammar signal to the reader that care was not taken in producing the manual, and this impression could also be transferred to the product. Let us consider some examples.

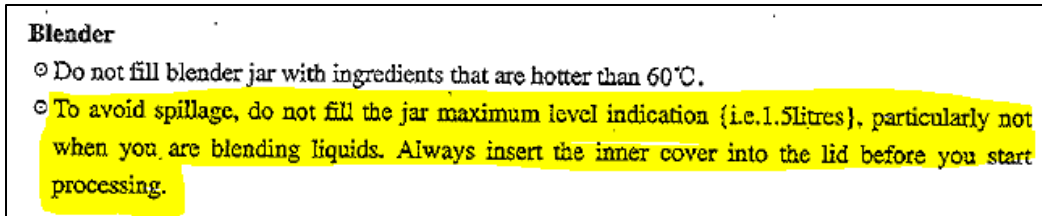

Figure 16: Examples of bad word choices used in the manual.

Figure 16 is from page 1 of the manual. A reader may have to read this twice or more times to figure out that the preposition “to” is missing. The sentence should have read: “To avoid spillage, do not fill the jar **TO** maximum level indication... blending liquids.”

Let us consider some other examples from page 3 of the manual. See figure 17.

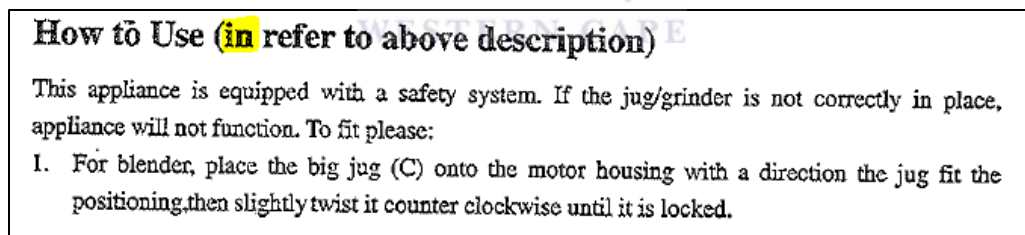

Figure 17: Examples of grammatical errors in the manual.

In figure 17, we see that the preposition “in” should not be there. Bullet point number 1 is difficult to understand. It reads: “For blender, place the big jug (C) onto the motor housing *with a direction the jug fit the positioning*, then slightly twist it counter-clockwise until it is locked”. The prepositional phrase in italics is difficult to process. The writer may have had in mind one of the following actions: (1) place the jug firmly onto the motor housing, then slightly twist it counter-clockwise until it is locked; (2) place the jug onto the motor housing to fit its counterpart, then slightly twist it counter-clockwise until it is locked; or (3) place the jug onto the

motor housing with the handle facing the left/right side, then slightly twist it counter-clockwise until it is locked.

In figure 18, in the final bullet point, we find yet another example.

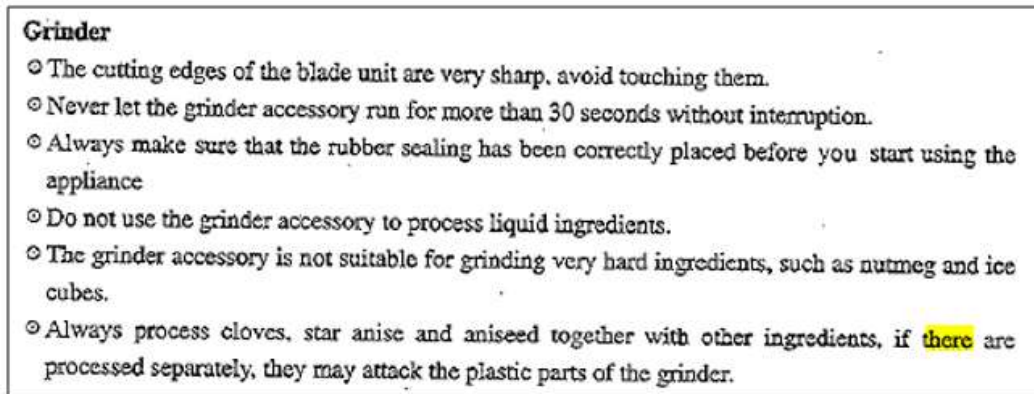

Figure 18: Grammatical errors found in an instruction in the Logik manual.

In figure 18, several errors are found in the following instruction: *“Always process cloves, star anise and aniseed together with other ingredients, if there are processed separately, they may attack the plastic parts of the grinder.”* Firstly, there should be a full stop or, preferably, a semi-colon after “ingredients”. Secondly, the pronoun “they” (standing for cloves, aniseed, etc.) is what is required instead of “there” in the phrase *“...if there are processed separately...”*. Thirdly, the choice of the word “attack” seems inappropriate. Seeds cannot attack, but can damage the plastic parts of the grinder.

Let us consider another example of inappropriate word choice. Figure 19 shows information relating to “Storage and sprinkling facilities”. Upon interacting with the text for the first time, one would possibly assume that what follows after the heading is information related to the storage of the blender and its parts. However, the word “sprinkling facilities” is where confusion arises.

### Storage and sprinkling facilities

After you have processed the ingredients, you can unscrew the mill from the appliance.  
If you remove the blade unit and replace it with the lid (fig.16), you can store the ingredients, for insurance in the refrigerator. You can also sprinkle the ingredient onto a dish via the reclosable sprinkling hole in the lid handy for on the table!

Figure 19: An excerpt of page 4 of the Logik manual with examples of inappropriate word choices.

In figure 19, the writer is referring to the safe keeping of left-over foods and/or any processed ingredients and not the storage of the kitchen blender, as one might assume. In addition to the above, the second sentence tells the reader that whatever ingredients are left over can be used for future use. Although the word “insurance” can be used in various instances to refer to more than one thing, it simply is inappropriate in the current context. To store ingredients for “insurance” (as the instruction states) is an unusual choice of words and does not necessarily fit the context of this manual. The writer could choose a more suitable phrase relating to food care and preservation, such as “safe keeping” or “later use”.

The last sentence in figure 19 is relatively confusing, and takes us back to the issue of grammar. It reads: “You can also sprinkle the ingredient onto a dish via the reclosable sprinkling hole in the lid handy for on the table!”. The last phrase “...handy for on the table!” is problematic. The writer might have intended to say the following: : “*You can also sprinkle the ingredients onto a dish through the reclosable sprinkling hole in the lid, which is handy for use on the dinner table.*” It would then make more sense to also indicate that this specific product part can be used as a handy sprinkling hole.

#### 4.1.5 Omitted and implied information in the Logik manual

The Logik manual has a few issues relating to omitted information. Terms and phrases are used within instructions in a manner that suggests they had been encountered previously, when that is in fact not the case. We will now look at examples where product parts and processes are mentioned but not explained to the user of the product in the manual. The highlighted phrase, as can be seen in bullet 5 in figure 20, is the only place where the writer uses the phrase “closed position”.

- Blender**
- ⊙ Do not fill blender jar with ingredients that are hotter than 60°C.
  - ⊙ To avoid spillage, do not fill the jar maximum level indication (i.e.1.5litres), particularly not when you are blending liquids. Always insert the inner cover into the lid before you start processing.
  - ⊙ Never put your hand or any other object in the blender jar while the appliance is switched on. If necessary, use a spatula to remove food from the wall of the jar after you have switched the blender off.
  - ⊙ Before you start using the blender, make sure that the blade unit is securely fitted to the blender jug.
  - ⊙ Always make sure that the lid is in "closed position" when processing ingredient.
  - ⊙ Do not drop the jar on a hard floor . Also avoid extreme thermal shocks. If the jar is very cold, rinse it well with lukewarm water before pouring in hot liquid

**Figure 20: An example of an implied phrase used once throughout the Logik manual and not referenced elsewhere.**

In figure 20, the blender instruction explains to the user to make sure that the lid is in a “closed position” before blending ingredients. One would generally assume that something is closed when a lid is simply placed on its counterpart. However, with the various product designs and the technology of today, lids can be secured in a number of ways including: pressing or pushing it onto the product to ensure a suction grip; placing the lid onto a product until the lid clicks into place; or a lid can be secured onto a product by turning it either clockwise or counter-clockwise.

In the case of the Logik manual, the phrase “closed position” is not explained to the user. In the images provided of the blender, there is no marking on the device labelled “closed position”. This lack of information could very well result in users hurting themselves or damaging the product in a bid to figure out what the “closed position” is.

Let us look at an example of another kind. In figure 21, the writer first uses a term for a functionality “safety system” leaving the meaning implied. At this point, the interested reader can only infer what the “safety system” does. Only when this functionality is introduced a second time later on in the text, in the form of a slightly different term “safety lock”, is its use explained (preventing the device from functioning). Of course, there is an issue of inconsistent terminology

here, and some readers may well have to resolve the challenge of determining whether the two expressions refer to the same thing.

**How to Use (in refer to above description)**

This appliance is equipped with a **safety system**. If the jug/grinder is not correctly in place, appliance will not function. To fit please:

1. For blender, place the big jug (C) onto the motor housing with a direction the jug fit the positioning, then slightly twist it counter clockwise until it is locked.
2. Dice the food to be blended and then add the liquid to a desired level but never exceed the maximum level marked.
3. Put the lid (B) on and lock by turning it.
4. Plug the appliance into power outlet and set the button of switch (F) to desired speed (1 or Pulse).
5. During blending, flavour can be added in by pouring it.
6. When blending is finished, turn the switch to 0 setting for stop and then remove the jug (C) by turning it clockwise.
7. To clean, follow the instruction of "Cleaning" as shown below..

**Built-in safety lock**

The appliance has been equipped with a built-in **"Safety Lock"** that prevents it from functioning if the accessories have been assembled incorrectly or have not been assembled at all.

Note: never use the accessories to turn the appliance on and off!

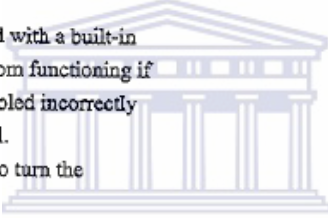

**Figure 21: A safety system and safety lock mechanism being mentioned with no further clarity or position of the mechanism on or within the product.**

In addition to the examples presented in figures 20 and 21, the Logik manual also makes mention of the words "stopper" and "quick clean button" as part of the its cleaning instructions.

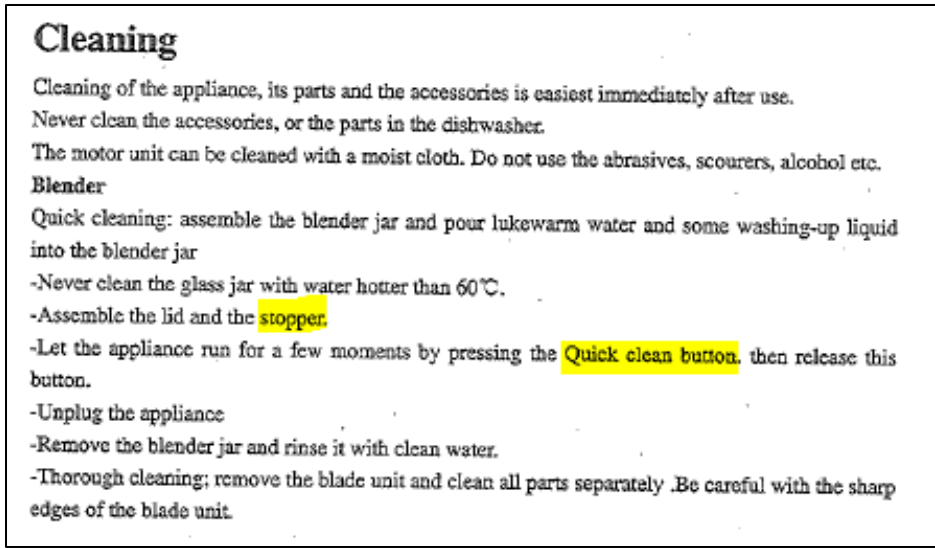

**Figure 22: Mentions of a stopper and quick clean button which have not been described as parts of the Logik blender.**

As may be recalled, neither a stopper nor a quick clean button were identified or described under the general product description in the manual. See figure 23.

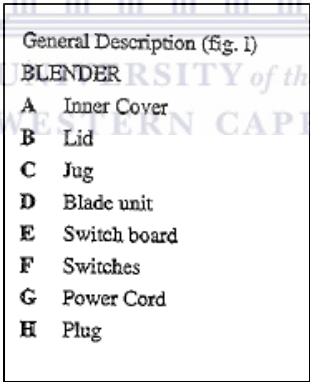

**Figure 23: A general description of the Logik product parts excluding the stopper and quick clean button as mentioned under the “Cleaning” instructions.**

These parts were also not in figure 5 that showed the various parts of the blender.

In summary, besides the safety lock/safety system question, the Logik manual mentions three other parts (stopper, quick clean button, closed position) without these parts having been identified in the graphics or explained in the text. In her assessment of technical manuals,



Ramaker (2007) emphasises that “in order to create a quality document [...] writers must be careful not to omit essential pieces of information.”

#### 4.1.6 Sequencing of information and sentence structure in the Logik manual

The CPA referred to the organisation of information as an issue that can potentially affect the understanding or the correct execution of an operation. In Chapter 2 (section 2.6), we examined a number of notions (frontloading, hierarchy of topics, chunking of groups of information, iconicity, etc.) relevant to the sequencing or organisation of information at the sentence level and beyond. For instance, it was considered inappropriate for there to be an instruction on assembling a device when the parts of the device have not previously been presented. Kintsch and Vipond (1979) stress that readers more easily process text when information is established in a hierarchy of topics and when chunks of information are grouped into meaningful units. The Logik manual opens itself to numerous criticisms on several of these points. Consider the examples around figure 24.

- 
- Blender**
- ⊙ Do not fill blender jar with ingredients that are hotter than 60°C.
  - ⊙ To avoid spillage, do not fill the jar maximum level indication (i.e. 1.5 litres), particularly not when you are blending liquids. Always insert the inner cover into the lid before you start processing.
  - ⊙ Never put your hand or any other object in the blender jar while the appliance is switched on. If necessary, use a spatula to remove food from the wall of the jar after you have switched the blender off.
  - ⊙ Before you start using the blender, make sure that the blade unit is securely fitted to the blender jug.
  - ⊙ Always make sure that the lid is in “closed position” when processing ingredient.
  - ⊙ Do not drop the jar on a hard floor. Also avoid extreme thermal shocks. If the jar is very cold, rinse it well with lukewarm water before pouring in hot liquid.

Figure 24: Chunks of information relating to various stages of using the Logik blender.

There would appear to be three kinds of information in figure 24, which is page 1 of the Logik manual. There is information around filling the blender jar (“Do not fill...60°C”; “To avoid spillage... blending liquids”); there is also information around setting up the device (“Before you start ... jug”; “Always make sure... ingredient”; the last sentence of the second bulleted point: “Always insert the inner cover... processing”); and finally, information on caring for the device

(third bulleted point; final bulleted point). Unfortunately (as the listing of instructions in figure 24 shows), the Logik manual does not follow what would have been a logical order of grouping or chunking together information that goes together. The reader encounters instructions on setting up the device for use in two bullet points separated by another point on caring for the device (cf. spatula). In terms of hierarchy, one might have expected that instructions on setting up the device (“*Before you start... jug*”; inserting the inner cover, etc.) would be presented before instructions on how to fill the jar.

In terms of frontloading, there is something in figure 24 to be commended. There is a good example in bulleted point 4 where the goal of the (main) action is first stated before the action that is the means to attaining that goal: “*Before you start using the blender, make sure that the blade unit is securely fitted to the blender jug.*” On the other hand, in terms of iconicity, there is a concern in “*If necessary, use a spatula to remove food from the wall of the jar after you have switched the blender off*”. One relevant condition (besides “if necessary”) for using the spatula is that the blender is switched off. This condition is however stated at the end of the sentence.

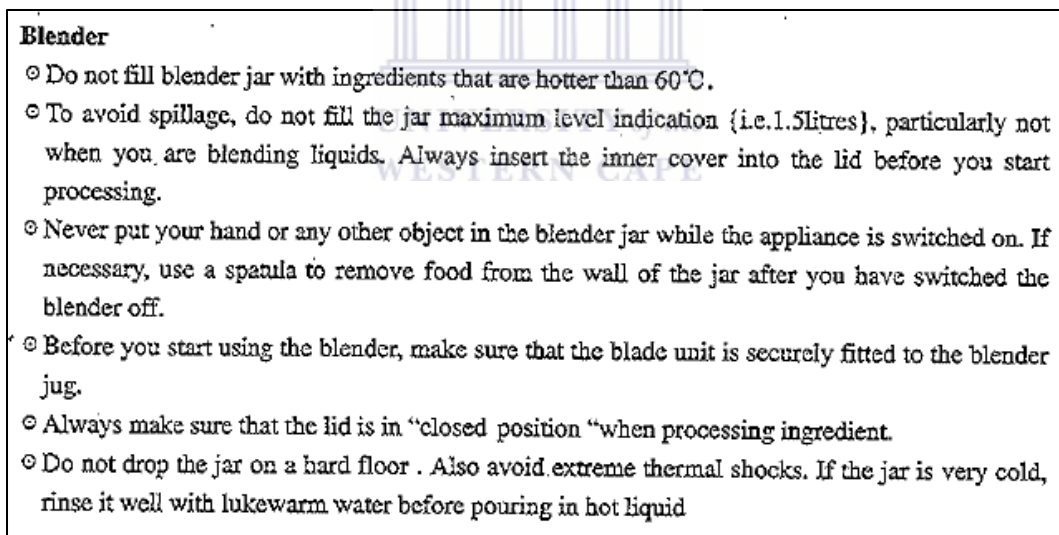
Perhaps of even greater concern is the observation that at the stage of all of these instructions (referring to parts of, or indications on, the blender) being presented, these parts have not been clarified. Let’s examine these instructions carefully and identify the parts which have not yet been clarified.

- Bullet number one: “*Do not fill **blender jar** with ingredients that are hotter than 60°C.*” At this stage in the manual, the user has not been introduced to the “blender jar” as yet. Also, no marked image or explanation is given to which the reader can refer to.

- Bullet number two: “*To avoid spillage, do not fill the jar maximum level indication {i.e.1.5litres}, particularly not when you are blending liquids. Always insert the **inner cover** into the lid before you start processing.*” Once again, the user of the product may not know what the “inner cover” is as mentioned in the instruction above. What was also referred to as the “blender jar” in the first instruction, is now simply referred to as the “jar”.

- Bullet number four: “*Before you start using the blender, make sure that the **blade unit** is securely fitted to the blender jug.*” This instruction mentions a component that has not been introduced previously, a “blade unit”, and what was previously described as a “blender jar” or “jar”, is now referred to as a “blender jug”.
- Bullet number five: “*Always make sure that the lid is in “**closed position**” “when processing ingredient.*” The above instruction immediately makes one question, what a “closed position” is.

Clearly, the reader may not be certain which component the writer is referring to, and with that, the dangers or precautions that come with handling the component. The sequence in which information is presented is therefore important. Kintsch and Vipond (1979) reiterate that readers more easily process text when information is established in a hierarchy of topics and when chunks of information are grouped into meaningful units. It is important that the user be introduced to the product components beforehand so that s/he is familiar with the parts before reading the instructions relating to the specific part. Woolever (1999: 238) states that technical writing in user manuals must be task-oriented, meaning that the organisation of information follows the order of tasks as they should be performed. The fact that the image of the kitchen blender only comes on the following page (page 2) and that the product descriptions are on page 3, goes against Woolever’s (1999) effective document design. It is also apparent why the CPA refers to organisation of information as an important component of what it means for product information to be understandable to the average individual.

#### **4.1.7 A brief summary of the Logik manual**

As some of the provisions in the CPA state that documents need to be produced in plain language so that one can understand the content and with visual representations which do not require relevant experience, after reviewing the Logik manual according to the various themes and in accordance with the CPA provisions, the manual reveals weak areas in terms of consistency, sentence structure, vocabulary as well as the lack of descriptive illustrations, and therefore violates the provisions. It is concerning as the document not only lacks vital information, such as warning notes and guarantee information, but also the basic idea of what it

is that a manual is supposed to achieve – taking the user of the product on a journey to successfully using that which s/he bought and to enjoy the outcomes thereof. On the other hand, the Logik manual produces an exploded image of the blender which is large enough to identify the various parts used to assemble the blender. There is also a good use of frontloading instructions.

However, due to the above mentioned shortfalls, the questionnaire was designed to challenge these areas and test whether possible users of a kitchen blender are able to fully understand what it is the manual expects them to do, whether the information provided allows them to complete it successfully and whether they feel empowered after completing what is required from them.

The following section will look at the Ottimo manual.



## 4.2 Ottimo Manual Observation

The Ottimo manual is the second manual to be analysed. The Ottimo product is manufactured in China and is marketed in South Africa. The English section of the Ottimo product manual is made up of a cover page and 6 information-packed pages, including important guarantee information regarding the product. The same pattern and layout of information is followed throughout the Portuguese and French sections of the manual as well. The information is presented in either bulleted or numbered form, all in the same font with a justified alignment.

The cover page of the Ottimo manual provides the reader with the brand name “Ottimo”, the tagline “AFFORDABLE QUALITY” as well as a heading which states what the document is – “INSTRUCTION MANUAL, STAND BLENDER” and on the right-hand side, a “ONE YEAR GUARANTEE” stamp.

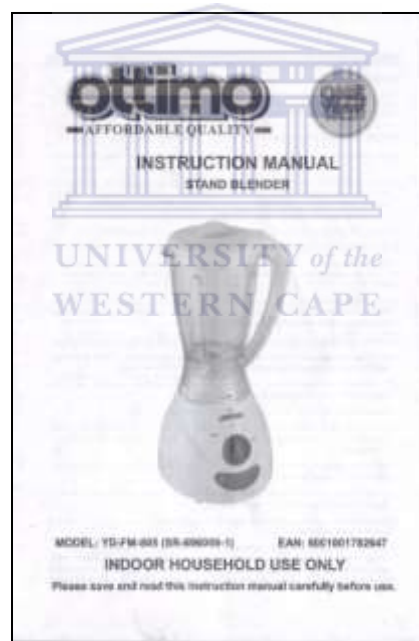

Figure 25: The cover page of the Ottimo instruction manual.

As seen in figure 25, the middle of the front page is a 3-dimensional image of the product with which the manual is accompanied. Below the image is the model code, the European Article Number (EAN) and a basic warning to the consumer (in upper case) to only use the product indoors and an instruction to the reader to keep the manual in safe use.

#### 4.2.1 Multimodal aspects of the Ottimo manual

The 6-page Ottimo manual produces a range of interesting image categories. On the front cover of the manual, the user is introduced to the first image which is the fully assembled kitchen blender, followed by the detailed exploded image of the blender on page 2, a third image is situated amongst detailed instructions on page 3, and lastly, a tiny icon representing a waste bin is seen on page 5. Images and their interaction with texts in the Ottimo manual give rise to a rich discussion around topics such as the following: the positioning of the images, the way in which they are labelled, their appropriate sizes and the way in which they complement or overpower the text in the manual.

As can be seen in figure 26, the cover manual is made up of the brand, product title, an image of the assembled product, product codes, as well as a guarantee stamp.

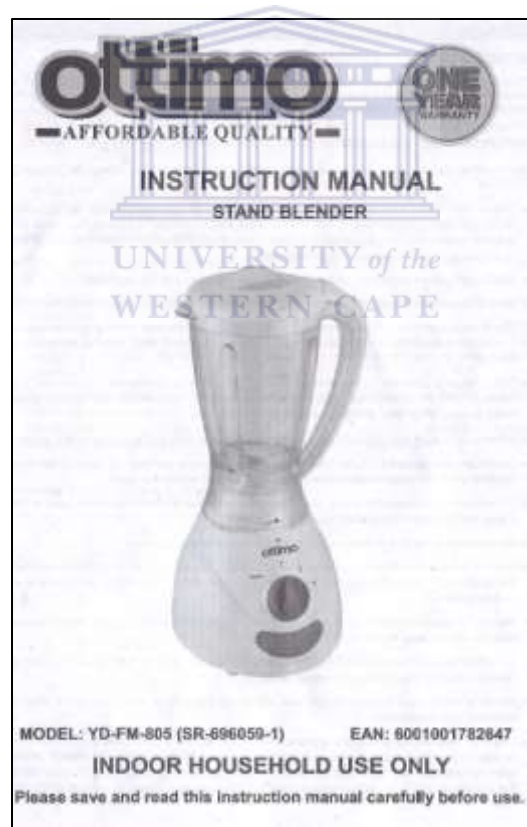

Figure 26: The first image displayed on the cover page of the Ottimo manual.

Compared to that of the Logik manual, what specifically stands out on the cover page is the guarantee stamp, as seen in figure 26.

Using Kress and Van Leeuwen's (2006) information value of left and right, the one-year warranty sticker is on the right of the page and the brand name situated more to the left. According to Kress and Van Leeuwen (2006: 180), "the right seems to be the side of the key information, of what the reader must pay particular attention to", with the left side being the part that is "already given, and is something the reader is assumed to know." In other words, the brand name is something the user is already aware of when the product was purchased, but the warranty sticker, on the other hand, is important, new information presented to the user and possibly information that determines whether or not the user will purchase the product, compared to others on the market. The warranty sticker is also bold and large enough for the user to see.

The second place where an image is found in the manual is on the bottom half of page two. Let us refer to figure 27 for further information.



## ENGLISH

- This appliance is not suitable for outdoor use. Do not use this appliance for anything other than its intended use.
- Do not touch the cutting blades and do not insert any foreign objects (e.g. knives, forks, spoons etc.) into the Jar while the product is operation. A spatula may be used only when the product is not in operation, avoiding the risk of serious injury.
- Never operate the product when the Jar is empty and do not remove the Jar lid before the blades come to a complete stop.
- Do not carry the appliance by the power cord.
- Blades are sharp. Handle carefully.
- Do not leave this appliance unattended during use. Always unplug the unit when not in use or before cleaning.
- Always operate the appliance on a smooth, even and stable surface. Do not place the unit on a hot surface.
- The manufacturer does not accept responsibility for any damage or injury caused by the improper or incorrect use of the appliance, or by repairs carried out by unauthorized personnel.
- In case of technical problems, switch off the machine and do not attempt to repair it yourself. Return the appliance to an authorized service facility for examination, adjustment or repair. Always insist on the use of original spare parts. Failure to comply with the above mentioned precautions and instructions, could affect the safe operation of this machine.

### KNOW YOUR STAND BLENDER



### SPECIFICATIONS

Rated voltage: AC 220-240V 50Hz  
Rated Power: 400W  
KB=1min  
Cord: 2-pin round plug

Figure 27: A second image - an exploded view of the Ottimo kitchen blender together with labelled parts.

In figure 27, we find the second image in the manual which is an exploded view of the kitchen blender marked with all the various parts as they should be assembled to complete the product.



As may be recalled, the exploded view image of the blender in the Logik manual is much larger than that of the Ottimo image. The image as seen in figure 27 is rather tiny and as a result could hamper the assembling of the product for those users who have difficulty reading or seeing. Backinger and Kingsley (1993: 42) advise writers and designers of manuals (and other documentation) to make use of graphics that are large enough to show the focal point. In other words, images should be clearly visible to see the various assembled parts and should be clearly marked and free from any form of distraction such as other page drawings or decorations.

When looking at the whole of page 2 of the Ottimo manual (refer to figure 27), it is evident that there is a wealth of text information, which seems to be overpowering the tiny image which is meant to direct the user into assembling the blender successfully. This can be problematic for senior users or even those whose eyesight is not good.

Another set of images is found on page 3. Different to that on the cover page and the exploded view image on page 2, this set of images is in a way self-explanatory and easily understood – with or without text. Let us look at figure 28.

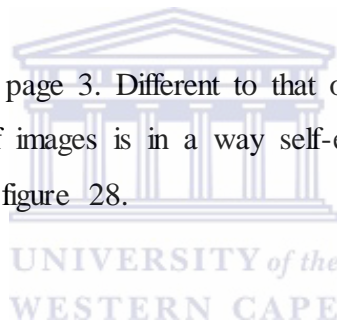

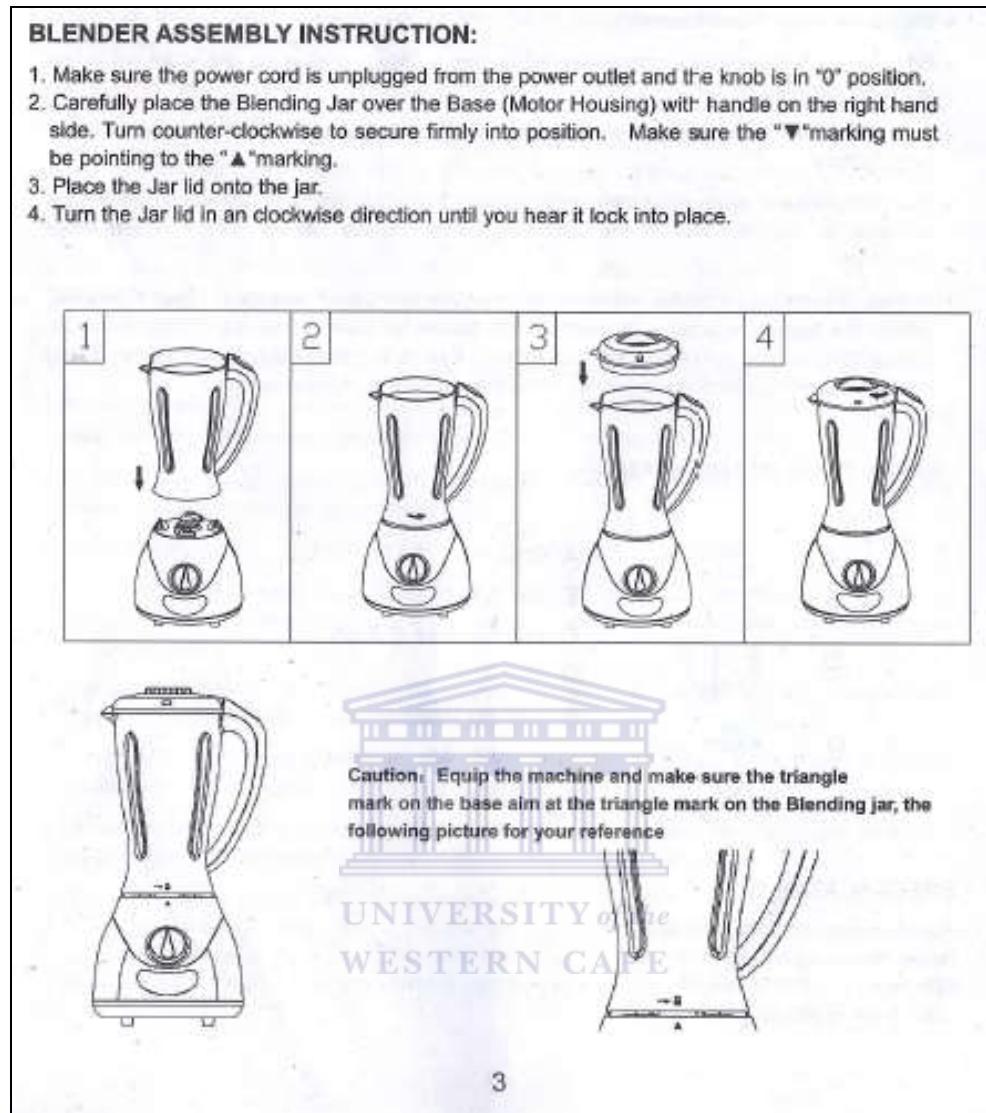

**Figure 28: A more detailed form of images with a combination of text.**

In figure 28 we see a different form of imagery compared to the first two images found in the manual. The collection of images produced on page 3 of the manual is a combination of images and texts. It is also a good example of Stöckl's (2009: 215) info-content image-text relation, which speaks about the link between the image and the text and how the one assists the other in elaborating and explaining the message or instruction. This is also similar to the complementarity relationship coined by Schriver (1997), which also looks at how the text and images complement each other by conveying different aspects of the content, helping the reader to understand the message that the writer is trying to get across (1997: 415).

This form of imagery in figure 28 also calls attention to the compositional element referred to as framing (Kress & Van Leeuwen 2006). Framing is brought about by rhythm and frames. The visual and textual elements are strongly connected even though they present their units of information separately, as is the case in this present example. Kress and Van Leeuwen (2006: 204) further explain that framing is usually indicated “by actual frames, white space between elements, or discontinuities of colour.” Although there’s no form of colour in the Ottimo manual, information in this example is presented in its own form and within its own boundaries.

By analysing the above images (refer to figure 28), we find that the instructions 1 to 4 are to a large extent a written representation of the images below them which practically convey to the user how the blender should be assembled. Neither element overpowers the other, but work in unison to convey the same message. They become especially important if the user does not read well, see well or does not read or understand the language used in the manual (Backinger & Kingsley, 1993: 39).

Woolever also brings a different meaning to this layout and states that the purpose of this combination is to clarify, simplify, emphasize and summarise information; to attract and impress the reader; or to save space in hardcopy manuals (1999: 126).

The last multimodal aspect in the manual is not an image *per se*, but an icon representing a municipal collection bin. Let us look at figure 29.

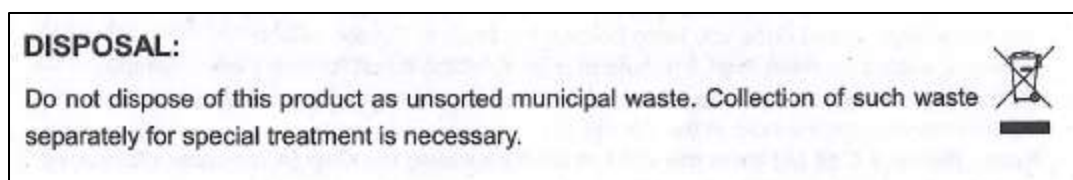

Figure 29: A representation of a municipal collection bin icon on page 5 of the Ottimo manual.

In figure 29, we find a representation of a municipal collection bin icon as found on page 5 of the manual. Besides the text which is provided, the icon is also helpful as people would in most cases be able to understand what is meant by the icon with the “X” over it. Generally, any image with an “X” marked across it indicates that whatever is crossed out is not allowed.

Correctly designed and displayed, the icon together with its explanation follows the advice written by Backinger and Kingsley (1993) when it comes to using graphics in manuals. They state that “an icon, which is a drawing that looks like the idea it is meant to represent, should only be used when there’s accompanying text to explain it. And because symbols and icons are difficult to design, the standardised form should be used so that it’s understood by the population” (1993: 40).

#### **4.2.2 Organisation of information in the Ottimo manual**

Generally, the Ottimo manual follows the generic conventions of manuals as evident by its introductory complimentary remark, followed by warnings, basic instructions and ending with the warranty information (Shäffner & Weisner, 2001: 51). On page 1, the manual thanks the reader for purchasing the “*Ottimo Stand Blender*” and assuring the reader that it is a reliable and good product. A request is then made to the reader to “*Please read the instructions carefully and keep them for future reference*”. The manual then ends with warranty information on page 6.

We find that throughout the manual, the writers favour the method of procedural instruction writing, a form of instruction type referred to by Eiriksdottir and Catrambone (2011: 752). They explain that these instructions usually consist of brief action statements that tell the user the condition for the action, what action to take, and the expected consequences. This form of instruction is also organised as a series of successive steps that need to be carried out to complete the task (2011: 750). Instructions in the Ottimo manual explain step-by-step how to use the blender from the time of removing it from its packaging, to the time of storing the blender.

In the table below (table 1) are examples of procedural instructions taken from the manual which are categorised under the definition of Eiriksdottir and Catrambone (2011).

	<i>(1) Brief action statement</i>	<i>(2) What action to take</i>	<i>(3) Expected consequences or explanations</i>
Fourth bullet on page 1	Check the power cord and plug regularly for any damage.	If the cord or the plug is damaged, it must be replaced by the manufacturer or a qualified person...	... in order to avoid an electrical hazard.
Fourteenth bullet on page 1	Use of an extension cord with this appliance is not recommended.	However, if it is necessary to use an extension lead, ensure that the lead is suited to the power consumption of the appliance...	... to avoid overheating of the extension cord, appliance or plug point.
Last bullet on page 2	In case of technical problems, switch off the machine and do not attempt to repair it yourself.	Return the appliance to an authorised service facility for examination, adjustment or repair. Always insist on the use of original spare parts.	Failure to comply with the above mentioned precautions and instructions, could affect the safe operation of this machine.
Instruction number 4 on page 3	Don't misuse the appliance.	Handle the blade with care.	It is very sharp.

**Table 1: Instructions taken from the manual, segmented according to the procedural instruction definition of Eiriksdottir and Catrambone (2011).**

The use of frontloading is also common in a few instructions found in the manual. Let us look at table 2.

	<b>Frontloader (Goal)</b>	<b>Instruction</b>
Eighth bullet on page 1	To reduce the risk of electric shock,	...do not immerse or expose the motor assembly, plug or power cord to water or any other liquid.
Last bullet on page 2	In case of technical problems,	... switch off the machine and do not attempt to repair it yourself.
Instruction number 3 on page 4	To ensure efficient mixing when blending dry mixtures,	... it may be necessary to stop the blender and push ingredients down the sides of the blending jar with a spatula.
Instruction number 9 on page 4	After you have completed blending,	... turn the speed knob (G) to the “0” position and unplug the cord from the wall outlet.

**Table 2: Instructions taken from the manual, segmented according to the frontloading definition of Woolever (1999).**

From table 2, we find that the user is first told the goal of the actions to be performed, rather than the instructions being stated first and the goal last. This not only aids in making the reading of complex and long sentences easier, it also sets the user’s expectations (Woolever, 1999).

Eiriksdottir and Catrambone’s notion of procedural instructions, as I have examined in table 1, goes against frontloading in some cases; e.g. the first and second tabular example: the reason (... *to avoid heating* and ...*in order to avoid an electrical hazard.*) is at the end of each instruction, as the consequence, rather than being the expectation and therefore being fronted. Even though these examples (of instructions found in the manual) do not appear to conform to either the frontloading principle or procedural instruction theory as a standard, it is evident that the instructions in the Ottimo manual still convey the underlying message in an understandable manner.

#### **4.2.3 Inconsistency in the use of terminology**

Although to a much lesser extent compared to the Logik manual, there are instances of variation and inconsistency in the use of terminology in the Ottimo manual.

In figure 30, we see an example with a part referred to as “blades”, “blender blades” and “blade”.

5. Wash the Blending Jar, Lid, Cap and blade in warm soapy water. Rinse under running water and dry thoroughly. Never use rough scouring pads or abrasive cleaners on any plastic or metal parts as the surface may be damaged.
6. Do not wash the Blending Jar, Lid and Cap in the dishwasher.
7. Never immerse the Base (Motor Housing) or power cord in water. Clean outside with a damp cloth and wipe with soft, dry cloth.
8. Wipe any excess food particles from the power cord.
9. **Caution: Use extreme care when handling the Blender blade. Do not touch blades with your fingers. The Blades are very sharp and can cause injury if touched.**

**Figure 30: Example of instances where variants of a term are used.**

As seen in figure 30, the writer makes use of synonymous terms/term variants to refer to what was introduced as the “cutting blades” on page 2 (of the Ottimo manual). Although they all include the base word “blade”, it may seem to the reader that there are more than one set of blades accompanying the kitchen blender because of the use of the word “blade” (referring to a singular item) compared to the word “blades” (referring to more than one item).

Throughout the manual, there is also reference made to an “appliance”, “electrical appliance”, “machine”, “product”, “stand blender” and the typical one, “blender”. It becomes problematic when instructions are read using these variants and the user may be confused as to which part of the blender the writer is referring to or if the writer is referring to the whole blender product itself.

Figure 31 below lists various excerpts taken from the manual where these terms were used interchangeably:

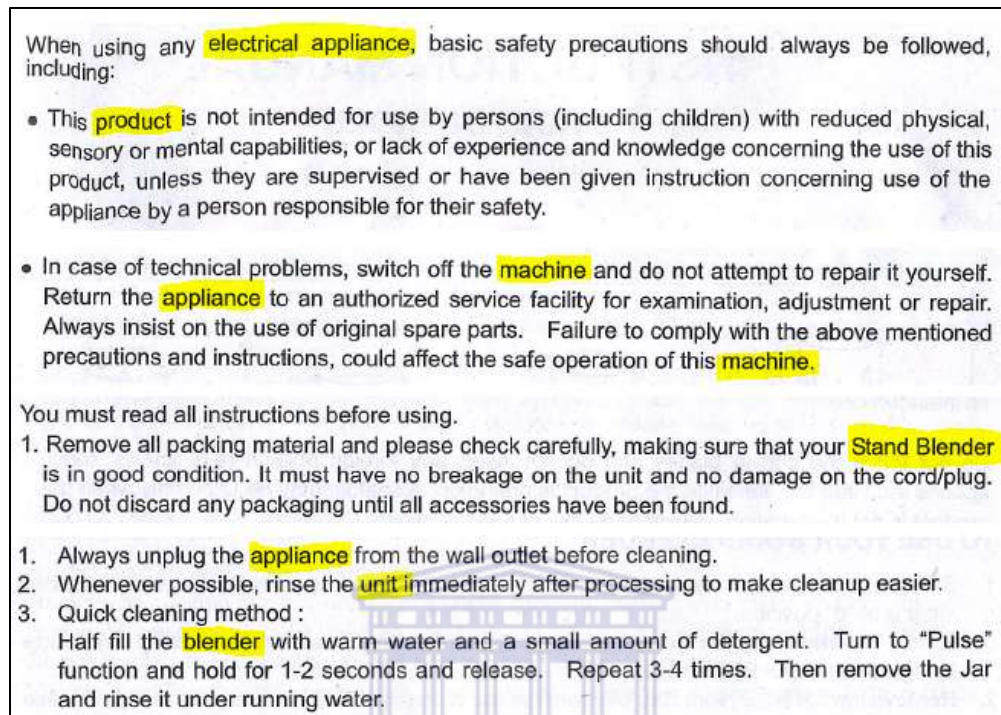

Figure 31: Example of instances where interchangeable terms are used to describe one product part.

Some of the instructions in figure 31 can leave the user asking the following possible questions:

- What constitutes the electrical appliance? The motor housing alone or the full product including the jug? In case of technical problems, which part of the product must be switched off? The motor housing or the blender? Should it be switched off at the plug or at the speed knob to stop the motor from running?
- If it needs to be repaired, should the full blender and its parts be taken back or the motor housing?
- When cleaning the blender, should the whole appliance be cleaned? What is a unit?

The above possible questions can be a hindrance if the user is faced with any of these situations to which there isn't much information provided.



#### 4.2.4 Grammatical and word choice issues in the Ottimo manual

Ramaker (2007) states that the writing found in technical manuals must be aimed at the audience's level of understanding and their familiarity with the product in order for it to be effective. There are however a few terms in the Ottimo manual which non-first-language English users may not immediately understand. Let us consider some examples and possible synonyms which could be used instead.

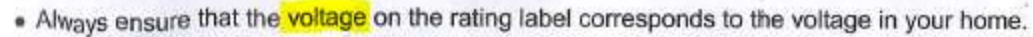

• Always ensure that the voltage on the rating label corresponds to the voltage in your home.

Figure 32: An instruction where the term used may not widely be understood by all users of the blender.

In figure 32, the word “voltage” may be confusing to people who do not understand electrical terms and jargon. This instruction may also leave users questioning the importance of the instruction and have them feeling anxious if it is not understood clearly or followed through. A clearer way of stating this instruction so that it is easily understood is to tell the user to cross reference the force or electrical current in the household to that of the label on the electric cord of the blender. One needs to be aware that the process of calculating voltage and electrical currents at home is not as easy as the instruction portrays and should not be done without proper equipment and under the supervision of an adult. This instruction does pose as a concern if people choose to scabble and interfere with electrical systems.

Let us look at a few more examples where difficult words are used in instructions throughout the manual. Let us consider figure 33.

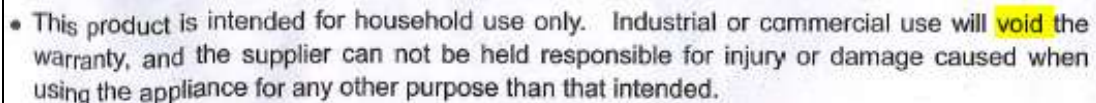

• This product is intended for household use only. Industrial or commercial use will void the warranty, and the supplier can not be held responsible for injury or damage caused when using the appliance for any other purpose than that intended.

Figure 33: An instruction where the term “void” may not widely be understood by all users of the blender.

In figure 33, the word “void” is rather complex to use in an instruction manual which is meant to serve a wide audience of buyers. A more suitable synonym to use would be “cancel” or “...no longer will the warranty be valid...”

In yet another instance, we find the following instruction as seen in figure 34.

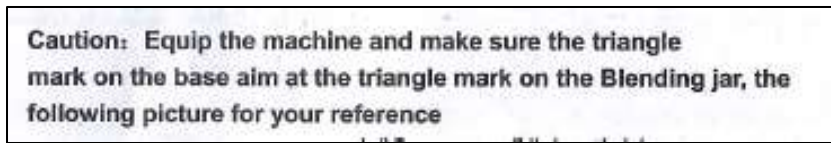

Figure 34: An example of inappropriate word choice in instructions in the Ottimo manual.

In figure 34, the user is asked to “equip” the machine before making use of it. In essence, the word equip implies that users should prepare, arm or even train the blender, which does not suite the context of this instruction. In this instance the basic word “assemble” would be a more appropriate word to use, and structuring the sentence in the following way would possibly make more sense as the user performs the action whilst reading the instruction: “*Caution: As you assemble the machine, make sure the triangle mark on the base (motor housing) is in line with the triangle mark on the blending jar. Use the following picture for your reference.*”

According to Smith (2003: 15) “the look and feel of the document can encourage consumers to begin reading and can promote deeper reading. Poor legibility, layout, and structure can discourage reading, but a user-friendly appearance and structure can encourage it.”

#### 4.2.5 A brief summary of the Ottimo manual

We are often told that manuals are produced with the purpose of the consumer in mind. After reviewing the Ottimo manual according to the theoretical frameworks presented in the literature review and with the CPA as a basis, we find that the manual presents itself as a nifty, information-packed document which, compared to the Logik manual, is an easier read, guided by headings, frameworks and manual structures. We find that the Ottimo manual is in line with what the CPA requires, adhering to the provisions which state that the document should be produced in such a way that requires minimal experience from the consumer; organisation of information that is on point; comprehensiveness and consistency throughout; and the use of illustrations aiding text. But although there’s a large presence of explanatory details in these texts and images, the images are rather tiny in comparison to the Logik manual.

Although the Ottimo manual is a form of good documentation, the questionnaire was still designed in such a way that it would challenge the user to find whether or not reading and deciphering the information presented is as good as what the document seems to be.



## CHAPTER 5

### ANALYSIS ON USER VIEWS AND EXPERIENCES

#### 5.0 Introduction

The goal of this chapter is to analyse the data from the responses of the participants to the questions regarding their understanding of the information in the manuals presented to them. It will also analyse how they use the manuals to perform a specific task. This chapter will enable us to achieve the second and third objectives of this study, viz. (respectively) obtaining users' views on how the semiotic resources employed in the manuals affect intelligibility and the extent to which typical or potential product owners can use the manuals to carry out specific tasks with the product. This analysis is preceded by an analysis of the respondents themselves.

#### 5.1 An analysis of the recipients involved in the study

The first batch of questions were asked to gather background information on the respondents: age, gender, the product that they are rating, whether they own a kitchen blender and, if so, how often they read the manual that accompanies the kitchen blender. Altogether, 46 individuals consented to completing the questionnaire. A breakdown of their gender and age groups are shown in Table 3 below.

	<19 years	20-40 years	41-60 years	>61 years	TOTAL
<b>MALE</b>	0	8	8	0	= 16
<b>FEMALE</b>	0	18	8	4	= 30
<b>TOTAL</b>	0	26	16	4	= 46

Table 3: Age groups of the 46 male and female participants.

Of the 46 individuals, 23 responded to the Logik manual questionnaire and the remaining 23 completed the Ottimo manual questionnaire. There were 16 male participants and a total of 30 female participants. These are grouped in Table 4 below.

	<b>Logik</b>	<b>Ottimo</b>	<b>TOTAL</b>
<b>MALE</b>	10	6	= 16
<b>FEMALE</b>	13	17	= 30
<b>TOTAL</b>	23	23	= 46

**Table 4: The product manual rated per brand.**

To obtain background information on respondents' familiarity with blenders, they were asked the following question: *"If you have a similar blender product, how often do you use it?"*. All respondents reported having blenders and using them. Table 5 is a breakdown of how many times each gender group made use of their blender.

	<b>WEEKLY</b>	<b>MONTHLY</b>	<b>FEW TIMES A YEAR</b>	<b>NO RESPONSE</b>	<b>TOTAL</b>
<b>MALE</b>	2	0	6	8	= 16
<b>FEMALE</b>	0	10	12	8	= 30
<b>TOTAL</b>	2	10	18	16	= 46

**Table 5: An account of how many times the male and female participants have used their blenders.**

Respondents' attention to user manuals was elicited by the following question: *"If your blender came with a manual, did you read it before using the product?"*.

Table 6 presents the data.

	MALE	FEMALE	TOTAL
<b>It did not come with a manual</b>	0	0	0
<b>Saw the manual but did not read it</b>	6	4	10
<b>Read the manual briefly</b>	3	18	21
<b>Read the manual carefully before using the product</b>	2	4	6
<b>No response</b>	5	4	9
<b>TOTAL</b>	16	30	46

**Table 6: An account of participants (male and female) consulting the manuals before using their blender.**

A follow-up question to the one above asked the following: *"If you ticked the option 'saw the manual but did not read it', what was your reason for doing so?"*. Some of the replies of those participants who chose to answer this question, are documented below:

- *It is time consuming to read the manual when one is eager to use a new appliance – Male*
- *It's a blender. It's not that hard to figure out – Male*
- *We do not read the complete manual if we buy a coffee maker or microwave for example – Female*
- *I know how they work – Female*
- *I don't think it's necessary to read the manual - Female*

From the basic background questions asked above, we found that most of the recipients owned a product blender, even though it might not have been either of the two brands which were analysed. Either the participant themselves owned the product or someone in their household did.

The majority of the participants who were willing to answer the questionnaires were between the ages of 20 and 60 years old. This is often the age group of homeowners or renters who own basic kitchen products. Male participants who had previously agreed to participate were later unwilling to when they browsed through the questionnaires. However, more females were willing to answer the questionnaires. This could be because females are more familiar with kitchen products and are able to relate to them more so than males.

It was also found that a total of 10 participants used their kitchen blender on a monthly basis, whereas 18 participants stated that they only use theirs a few times a year, and the remainder of participants (16) did not answer the question. The reasoning behind this could be that a kitchen blender is not an item which is used often in comparison to a kettle or toaster for example. The fact that one needs to assemble a kitchen blender is also time-consuming and cleaning the various parts can be tedious, and could also be part of the reason that participants do not often make use of it.

When asked if they read the manual or not, a total of 22 participants chose the option of “*reading the manual briefly*”. Furthermore, 10 participants “*saw the manual but did not read it*” and 6 participants felt that they “*read the manual carefully before using the product*”. As suggested by Mehlenbacher *et al* (2002: 730), manufacturers assume that people read the entire manual when in actual fact some people only read part of it or do not open it at all.

## **5.2 Logik Manual Questionnaire Interpretations**

### **5.2.1 Introduction**

After the general questions discussed above, participants had to answer questions specific to the blender make assigned to them. The questions relating to the Logik manual (as with the Ottimo manual) were based on instructions taken from the manual. The questions were asked to test whether or not these possible blender users understood what they read, what they were meant to do and if they could identify the various product parts as referred to in the manual. Questions were also asked to get a sense of how these possible blender users felt towards reading the

manual. The following section produces an account of all the responses to the Logik manual questionnaire.

### 5.2.2 An Account of Responses to the Logik Manual Questionnaire

Questions 1 and 2 related to instructions taken from the manual wherein specific product parts were mentioned. They read as follows:

1. Read the following passages from the manual that mention the words “stopper” and “motor housing”. Using figure 1<sup>5</sup> below as a guideline, answer the questions that follow:

-Assemble the lid and the stopper.

1. For blender, place the big jug (C) onto the motor housing with a direction the jug fit the positioning, then slightly twist it counter clockwise until it is locked.

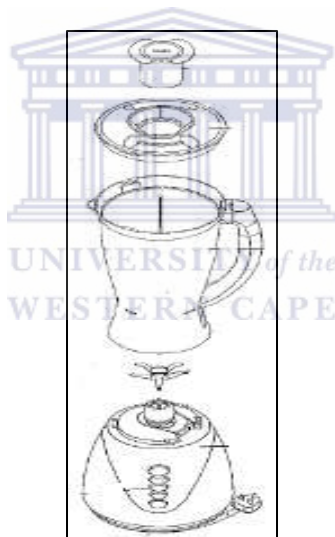

**Figure 1**

1.1 Identify and label the part “stopper” by drawing an arrow pointed away from the image and writing the name of the part at the tip of the arrow.

1.2 Identify and label the part “motor housing” by drawing an arrow pointed away from the image and writing the name of the part at the tip of the arrow.

1.3 Was this a difficult or confusing task?

- Yes
- No

---

<sup>5</sup> For the purpose of the questionnaire, the Logik kitchen blender was marked as *Figure 1* as a guideline to answer the question.



2. Study figure 2<sup>6</sup> below, which is the cover page of the Logik manual, and answer the questions that follow:

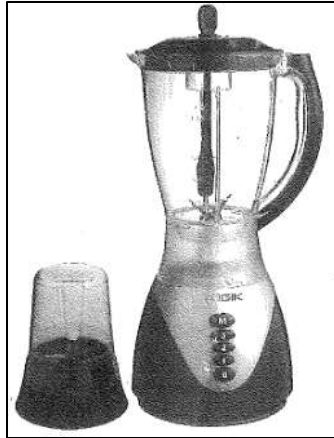

**Figure 2**

2.1 Use an arrow to show each part and write the name of the part by the tip of the arrow pointing away from the image:

-big jug

-jug

-inner cover

-motor

-switch board



2.2 Was this a difficult or confusing task?

- Yes
- No

Within the Logik manual, as discussed in the previous chapter, it was found that some parts were referred to by more than one name, for example, what was known as the “jug” was also referred to as “big jug” or as “blender jug”. Question 2 was also asked to test whether participants could identify one part referred to by various names, given the fact that the manual was designed in such a way that the instructions were presented on the one side of the page (page 1), followed by an exploded, marked image of the product on the opposite page (page 2), and a list of the product

---

<sup>6</sup> For the purpose of the questionnaire, the Logik kitchen blender and grinder was marked as *Figure 2* as a guideline to answer the question.

parts on the next page (page 3), resulting in the reader having to page over to view and match the various product parts to their accompanying letter (as marked on the image).

For the purpose of the analysis, questions 1 and 2 were combined showing the results of the 23 participants correctly or incorrectly identifying the various parts or choosing not to answer the question. Table 7 presents the results of participants who attempted these two questions or parts thereof.

	<b>CORRECTLY IDENTIFIED</b>	<b>INCORRECTLY IDENTIFIED</b>	<b>DID NOT ANSWER</b>
<b>1. 'STOPPER'</b>	8 (35%)	7 (30%)	8 (35%)
<b>2. 'MOTOR HOUSING'</b>	10 (44%)	6 (26%)	7 (30%)
<b>3. 'BIG JUG'</b>	18 (79%)	4 (17%)	1 (4%)
<b>4. 'JUG'</b>	9 (39%)	8 (35%)	6 (26%)
<b>5. 'INNER COVER'</b>	2 (9%)	20 (87%)	1 (4%)
<b>6. 'MOTOR'</b>	14 (61%)	6 (26%)	3 (13%)
<b>7. 'SWITCH BOARD'</b>	23 (100%)	0 (0%)	0 (0%)
<b>TOTAL</b>	84	51	26

**Table 7: Answers to questions 1 and 2 relating to terminological inconsistency and identification of parts.**

Table 7 shows that of 6 of the 7 items, more participants correctly identified the parts. It is a reflection of the negative effects of inconsistently used terminology that: (a) on item 5 as many as 20 participants got the answer wrong; (b) on items 1 and 4, only 5% and 4% more respondents respectively identified the parts correctly than those who did not. With respect to item 5 in which an overwhelming 20 participants wrongly identified the part, the assumption was that the "lid" was the same part as the "inner cover". The inner cover is in actual fact a separate product part which fits into the lid and allows for easily adding extra ingredients (through the opening) whilst the blender is in operation.

When asked whether the above question, relating to identifying the various product parts, was difficult or confusing, 7 participants answered that it was not difficult or confusing, 4 did not answer the question and a total of 12 participants said the question was confusing and difficult to understand. It is a further reflection of the negative effect of inconsistently used terminology that just over half of the participants found it difficult or confusing to identify the parts of the product manual which is important in assembling the kitchen blender. As with any product, if one is unable to fully understand the operation process, or even the placing together of parts to assemble the product, it is of limited use to the person wishing to use the product. In actual fact, a document that is not produced in plain language, with adequate information, gives way to potential instances where the user can injure him/herself as well as damage the product. This goes against that which the CPA represents.

Question 3 of the Logik questionnaire was interested in how the respondents understood the term “appliance”. The question read as follows: “*Read the following passages from the manual that mention the word ‘appliance’ and using figure 3<sup>7</sup> below as a guideline, answer the questions that follow...*”

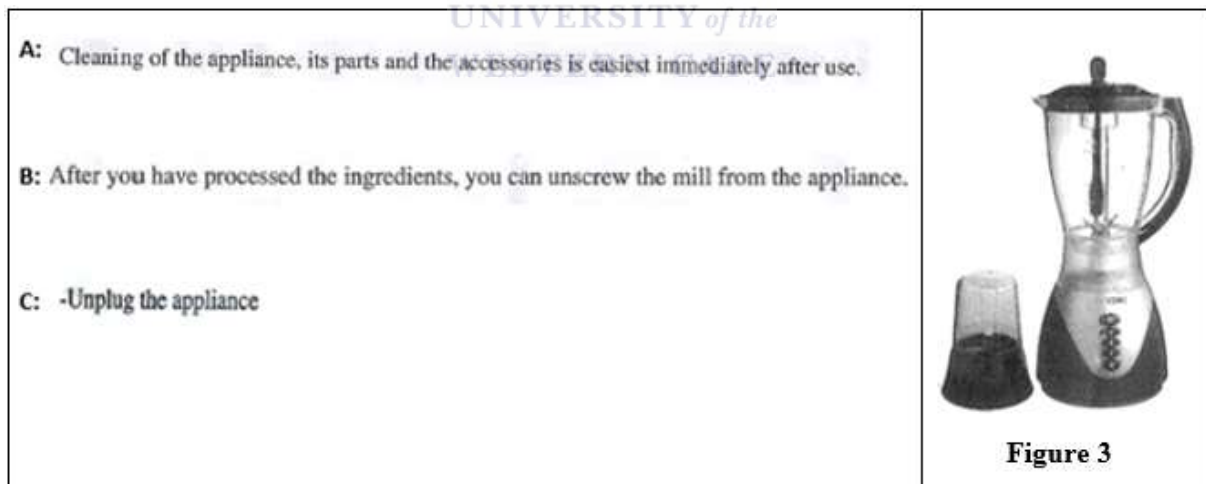

**Figure 35: Excerpts and accompanying Logik image used in question 3 relating to terminology inconsistency and identification.**

*3.1 In figure 3, what does “appliance” in text A above refer to? Draw a line which you label “appliance in A” to point to the appliance referred to in the image.*

<sup>7</sup> For the purpose of the questionnaire, the Logik kitchen blender and grinder was marked as *Figure 3* as a guideline to answer the question.

3.2 Again in figure 3, what does “appliance” in text B above refer to? Draw a line which you label “appliance in B” to point to the appliance referred to in the image.

3.3 Still referring to figure 3, what does “appliance” in text C above refer to? Draw a line which you label “appliance in C” to point to the appliance referred to in the image.

3.4. Was this a difficult or confusing task?

- Yes
- No

Table 8 presents a summary of the results of participants who attempted to identify the parts referred to as “appliance” in the instructions:

	<b>CORRECTLY IDENTIFIED</b>	<b>INCORRECTLY IDENTIFIED</b>	<b>DID NOT ANSWER</b>
<b>3.1 Appliance in A</b>	13 (57%)	4 (17%)	6 (26%)
<b>3.2 Appliance in B</b>	5 (22%)	12 (52%)	6 (26%)
<b>3.3 Appliance in C</b>	18 (78%)	0 (0%)	5 (22%)
<b>TOTAL</b>	36	16	17

**Table 8: Answers to question 3 relating to terminological inconsistency and identification of parts.**

Table 8 shows us that a total of 36 parts mentioned as “appliance” were correctly identified in the relevant instructions. A total of 16 parts were incorrectly identified and a total 17 parts were unaccounted for. With a difference of 20 between the total of correct versus incorrect responses, this tells us that there are many variations and understandings of how one could decipher this instruction. It also lends credence to the fact that word choices and terminology have a great influence on the way instructions are understood, in turn, affecting the way the user performs the required actions.

When looking at the instructions mentioning the term “appliance”, we find that in A, all parts except the motor housing (switch board) can be cleaned immediately after use. One can therefore not clean the appliance – which in this instruction is referred to as the motor housing (switch board) – but can only clean the parts and accessories such as the jug, blades, inner cover and lid. In this case 57% of the participants understood it as such.

In instruction B, the word “appliance” refers to as the motor housing (switch board). For better reading and understanding, one would unscrew the mill from the motor housing (switch board) instead of unscrewing it from the “appliance”. Only 22% of participants could relate to this being the reason for the correct answer they produced.

In instruction C, it can be argued that the “appliance” as used in the instruction can either refer to the entire assembled kitchen blender – in which 35% (8 participants) believed it to be as such - or it can refer to the motor housing (switch board) when one is done using the blender – in which 43% (10 participants) believed it to be so. From these variations we find that misperceptions are easily formed, since the word “appliance” is referred to by various parts of the kitchen blender throughout the manual including in the above instructions. 65% (15) of the participants who answered the follow-up question agreed that the above question was difficult and confusing.

While questions 1 – 3 had to do with inconsistently used terminology, question 4 had to do with multimodality. It sought to analyse the heading on the cover page of the manual and how it related to the graphics. Essentially, it was about determining whether respondents were able to distinguish between the blender and grinder. A screenshot of the cover page of the Logik manual is seen in figure 36 below:

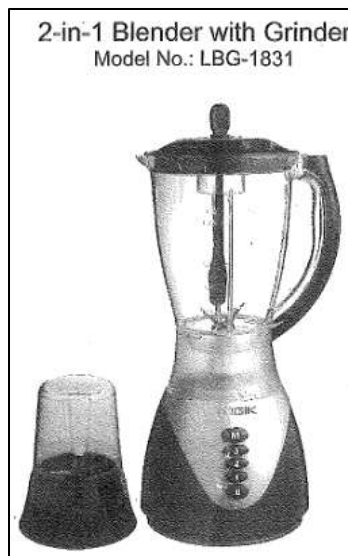

**Figure 36: The front page of the Logik manual used in the questionnaire.**

The question read as follows: “*Read the descriptions in figure 4<sup>8</sup>. Now draw a line with an arrow and write 1 or 2 by the tip of the arrow pointing away from the image, showing which is the blender (1) and which is the grinder (2)?*”

Table 9 presents the results of participants who correctly and incorrectly identified the blender and grinder parts according to the heading on the cover page of the manual.

<b>No. of participants correctly identifying blender and grinder</b>	<b>No. of participants incorrectly identifying blender and grinder</b>	<b>A breakdown of the incorrect responses</b>
7 (30%)	13 (57%)	7 (30%) – identifying blender as both blender and grinder  1 (4%) – Identifying grinder as blender and blender as grinder.  5 (22.7%) – did not answer the question

**Table 9: Answers to question 4 relating to sequencing of information in the heading of the cover page.**

Table 9 shows that of the 2 product parts presented on the cover page of the manual, and of the 87% of participants who answered the question, 7 (30%) participants correctly identified which is the blender and which is the grinder and a total of 13 participants incorrectly identified these 2 product parts. Of those 13 participants who got it wrong, 7 (30%) participants indicated that the blender was both the grinder as well the blender; 1 (4%) participant indicated that the larger product in the image was the grinder and that the smaller product was the blender, and the remaining 5 (22.7%) participants did not answer the question. The incorrect identifications come as a result of the left-to-right sequence of the graphics (grinder, then blender) differing from the sequence in the heading “2-in-1 Blender and Grinder”.

Of those who answered whether the question was difficult or confusing, 7 (30%) respondents replied that it was indeed difficult or confusing, 5 (22%) indicated that this question was not difficult or confusing and the remaining 11 (48%) respondents did not answer this specific question. It is of vital importance that information presented on the front page of any document

<sup>8</sup> For the purpose of the questionnaire, *Figure 4* referred to the image as noted in the Logik manual questionnaire.

be factually correct and free of errors. Users often do not have the time to scrutinise a manual from the beginning to the end, and as Mehlenbacher (2003) emphasises, it is important that the information is effective and meaningful, especially when it comes to **subject** and **chapter headings** (Mehlenbacher, 2003: 16).

It would be recalled from Chapter 4 that the Logik manual had an unlabelled exploded view of the blender on a page (2) but then provided names for the parts on a different page (3). Question 5 sought to determine whether respondents would be able to find names for parts in the exploded views and how easily. The participants were to identify the parts referred to as “switch board” and “inner cover”, and to state where in the manual the information was found. The text of the question was as follows:

5. Study figure 5<sup>9</sup> below (taken from page 2 of the Logik manual), then answer the questions that follow:

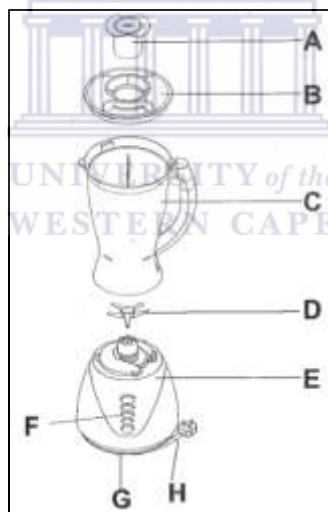

Figure 5

5.1 Identify the switch board by writing SB close to the letter representing the switch board.

5.2 How and where did you find the answer **in the manual**? Explain:

.....

5.3 Identify the inner cover by writing IC close to the letter representing the inner cover.

5.4 How and where did you find the answer **in the manual**? Explain:

.....

<sup>9</sup> For the purpose of the questionnaire, Figure 5 referred to the image as noted in the Logik manual questionnaire.

The fact that the general description was on the following page resulted in the participant having to page over to find the parts' descriptions. Table 10 provides a combination of responses to the question:

	<b>CORRECTLY IDENTIFIED</b>	<b>INCORRECTLY IDENTIFIED</b>	<b>DID NOT ANSWER</b>
<b>SB (switch board)</b>	10 (44%)	2 (9%)	11 (48%)
<b>IC (inner cover)</b>	10 (44%)	1 (4%)	12 (52%)

**Table 10: a combination of the responses to question 5 relating to product identification and sequencing of information.**

When asked where in the manual participants found the information, their responses were as follows:

	<b>Read through the manual</b>	<b>On page 3 of the manual/ Under "General description"</b>	<b>Did not answer the question</b>
<i>How and where did you find the answer in the manual?</i>	7 (30%)	10 (44%)	6 (26%)

**Table 11: a combination of the responses to question 5.**

Table 11 shows that of the 74% who answered the question, 30% indicated that they read through or looked through the manual to find the description of the parts, 44% specifically indicated that they found the descriptions on page 3 of the manuals, and the remaining 26% did not answer the specific question. This tells us that quite a bit of time was spent successfully answering this question, and finding the correct labelled parts, often resulting in unnecessary wasted time. Woolever (1999) stresses the fact that placing the graphic close to the text not only avoids confusion but also having to page back and forth to find information.



Following question 5, question 6 investigated whether participants were able to locate an image marked as “fig.1” next to the general description heading on page 3 of the product manual. The text of the question was as follows:

6. In figure 6<sup>10</sup> below, taken from page 3 of the Logik manual, reference is made to fig. 1.

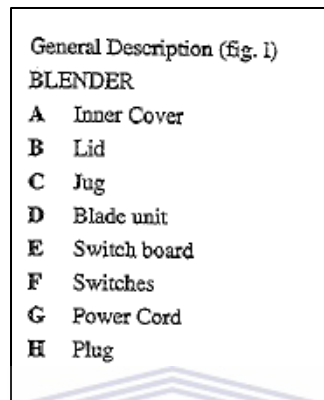

Figure 6

6.1 Is there anywhere **in the manual** you find an image marked as fig. 1?

- Yes
- No

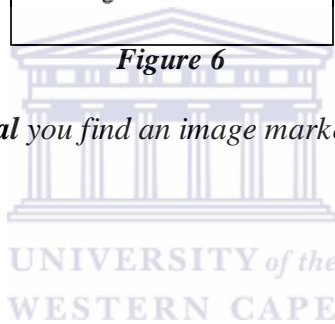

Table 12 provides a breakdown of the responses to question 6.

	YES	NO	DID NOT ANSWER THE QUESTION
<i>Is there anywhere in the manual you find an image marked as fig. 1?</i>	1 (4%)	20 (87%)	2 (9%)

Table 12: a breakdown of the yes/no responses to question 6.

From the responses to the question, 2 participants did not answer the question and 1 participant indicated that he located the marked figure (which is non-existent in the manual), with 20 participants stating “no”, they did not find an image marked as “fig.1” or “figure 1”.

As one can recall from Chapter 4, the Logik manual does not have an image labelled “fig.1” or “figure 1”. As a matter of fact, there are no images marked in the manual. The only image in the

<sup>10</sup> For the purpose of the questionnaire, Figure 6 referred to the image as noted in the Logik manual questionnaire.

manual is the exploded view of the appliance (on page 2) which includes the switch board, jug and its various parts. The fact that there is no figure which is marked in the manual, tells us that participants had to read through the manual and page back and forth to find what was claimed to be “fig.1”, but found nothing as such in the manual.

In the following question 7, similar to question 6 above, participants were once again asked whether they were able to locate “fig.16” as mentioned in the instructions below, taken from the Logik manual. The text of the question was as follows:

7. Read the following passage then answer the question that follows:

#### **Storage and sprinkling facilities**

After you have processed the ingredients, you can unscrew the mill from the appliance. If you remove the blade unit and replace it with the lid (fig.16), you can store the ingredients, for insurance in the refrigerator. You can also sprinkle the ingredient onto a dish via the reclosable sprinkling hole in the lid handy for on the table!

7.1 Is there anywhere *in the manual* you find an image marked as fig. 16?

- Yes
- No

22 (96%) respondents, answered “no”, meaning that they were not able to locate an image marked as such in the manual, with the exception of 1 (4%) participant answering “yes”. Once again we find that the Logik manual incorrectly states that there is an image marked as “fig.16”, but none is found in the manual. According to Kent (2006), recent studies suggest that average readers spend only five minutes looking unsuccessfully for information before they give up and try something else. This means that one of the most critical factors for the success of our manuals is how long it takes readers to find information.

The Logik manual often refers to various parts by its synonym. For example, the jug is also referred to as a big jug or a blender jug. Under the instructions supplied for the grinder use, parts

including *beaker*, *motor unit* and *mill* are mentioned. In question 8, the participants were asked to identify these parts in the questionnaire. The text of the question was as follows:

8. Read the following description which mentions the words “*mill*”, “*motor unit*” and “*beaker*”, and using figure 7<sup>11</sup> below as a guideline, answer the questions which follow:

**Grinder**  
-Unplug the appliance  
-Detach the mill from the motor unit.  
-Clean the beaker, the lid and the blade unit in lukewarm water

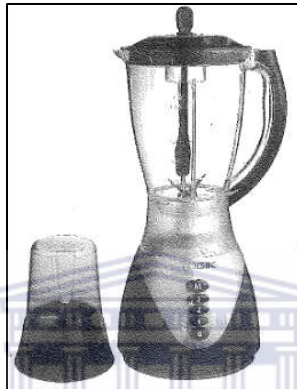

**Figure 7**

8.1 Using figure 7 above, identify the following parts by labelling them. Use a line with an arrow to show each part and write the name of the part by the tip of the arrow pointing away from the image:

- *Beaker*
- *Motor unit*
- *Mill*

8.2 Was this a difficult or confusing task?

- Yes*
- No*

8.3 Briefly explain:

.....

<sup>11</sup> For the purpose of the questionnaire, *Figure 7* referred to the image as noted in the Logik manual questionnaire.

Table 13 presents the results of the correctly and incorrectly identified parts in question 8.

	<b>CORRECTLY IDENTIFIED</b>	<b>INCORRECTLY IDENTIFIED</b>	<b>DID NOT ANSWER THE QUESTION</b>
<b>Beaker</b>	2 (9%)	12 (52%)	9 (39%)
<b>Motor unit</b>	12 (52.2%)	4 (17.4%)	7 (30.4%)
<b>Mill</b>	0	12 (52%)	11 (48%)

**Table 13: a breakdown of the responses to question 8.**

In table 13, of the parts mentioned, 14 participants correctly identified 2 of the 3 parts, and 28 participants incorrectly identified the beaker, motor unit and mill. Approximately 52% understood that the motor unit was also known as the switch board and 9% understood the beaker to be the grinder as well. Just over half of the participants (52%) who answered the question incorrectly identified the mill and only approximately 17% were not sure about the motor unit being the switch board. Of those who did not attempt identifying the parts, 9 participants did not identify the beaker, 7 participants did not identify the motor unit (also known as the switch board) and 11 participants did not identify the mill.

This can be rather problematic for people whose first language is not English and who may not fully understand the various terms used for one specific part. This confirms Schmitz's (2007) view concerning the inconsistent use of terminology in computer keyboard instructions. He stated that the inconsistent use of terms leaves the consumer confused and frustrated because of the time wasted to try and figure out the different parts and how they work.

When asked whether the task of identifying the part was difficult or confusing, of the participants who answered this question, the majority said "yes" it was difficult or confusing. Their reasons for saying so were as follows:

- *"There is no basic description of parts and parts are also given different names in [the] manual."*
- *"I couldn't see it in the manual."*
- *"There is no figure or guide describing or pointing out those parts."*

- “Beaker or mill are not marked in the manual or properly described.”
- “There’s no description however in the manual about where the different parts are.”

In question 9, participants were asked to comment on whether or not the blender parts in the exploded view, provided on page 2 of the Logik manual, were marked clearly, or its parts displayed clearly. The question read as follows:

9. Refer to figure 8<sup>12</sup> below and answer the question that follows.

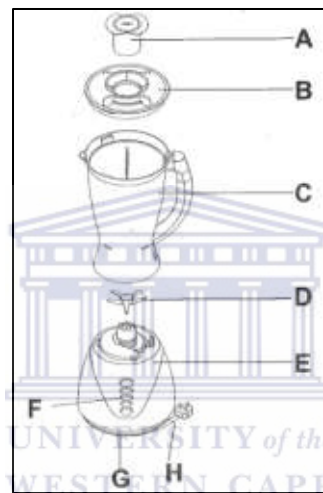

**Figure 8**

*Are the parts of the blender clearly displayed?*

- Yes
- No

Table 14 provides a breakdown to the responses in question 9.

	<b>YES</b>	<b>NO</b>	<b>DID NOT ANSWER THE QUESTION</b>
<b><i>Are the parts of the blender clearly displayed?</i></b>	16 (69%)	5 (22%)	2 (9%)

**Table 14: a breakdown of the yes/no responses to question 9.**

<sup>12</sup> For the purpose of the questionnaire, *Figure 8* referred to the image as noted in the Logik manual questionnaire.

Of the 21 (91%) participants who answered the question, 16 agreed that the image displayed the parts clearly, 5 participants answered that the parts were not clearly displayed, with the remainder of the participants (2) not answering the question. According to Ramaker (2007), when including any sort of graphic, descriptive figure titles and captions must be provided in order for the text and graphics to work together. If the caption for the images is not descriptive enough and readers need to refer to the text to make sense of them, then the images are not doing what they are supposed to be doing (Woolever, 1999: 126).

Question 10 required the participants to indicate where the part labelled D should fit in, according to their understanding of the image. The question read as follows:

*10. Refer to figure 8 in the previous question, and pay attention to the part labelled D. In your view, where does the image suggest the part labelled D should be? Tick one option.*

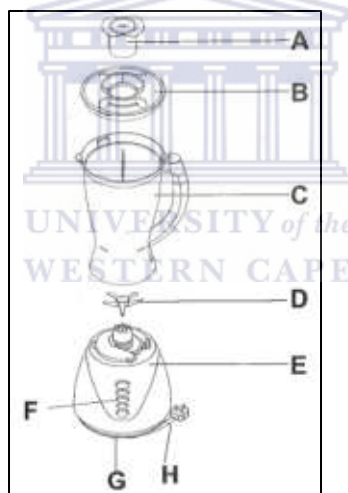

**Figure 8**

- In the part labelled E*
- In the part labelled C*

Of the 18 (78%) participants who answered the question, only 7 (30%) correctly identified that the part labelled D should fit into the part labelled C. 11 (48%) participants incorrectly claimed that the part D should be assembled into the part labelled E. When assembling the kitchen blender, the blades (part D) should in actual fact be in the jug (part C), which is then placed on the motor housing (part E). Because of the incorrect marking of the structure and its parts in the

image, users could incorrectly assemble the kitchen blender and, in the process, cause harm to themselves or damage the product.

Question 11 referred to an instruction labelled as number 7 on page 3 of the manual. Refer to figure 37.

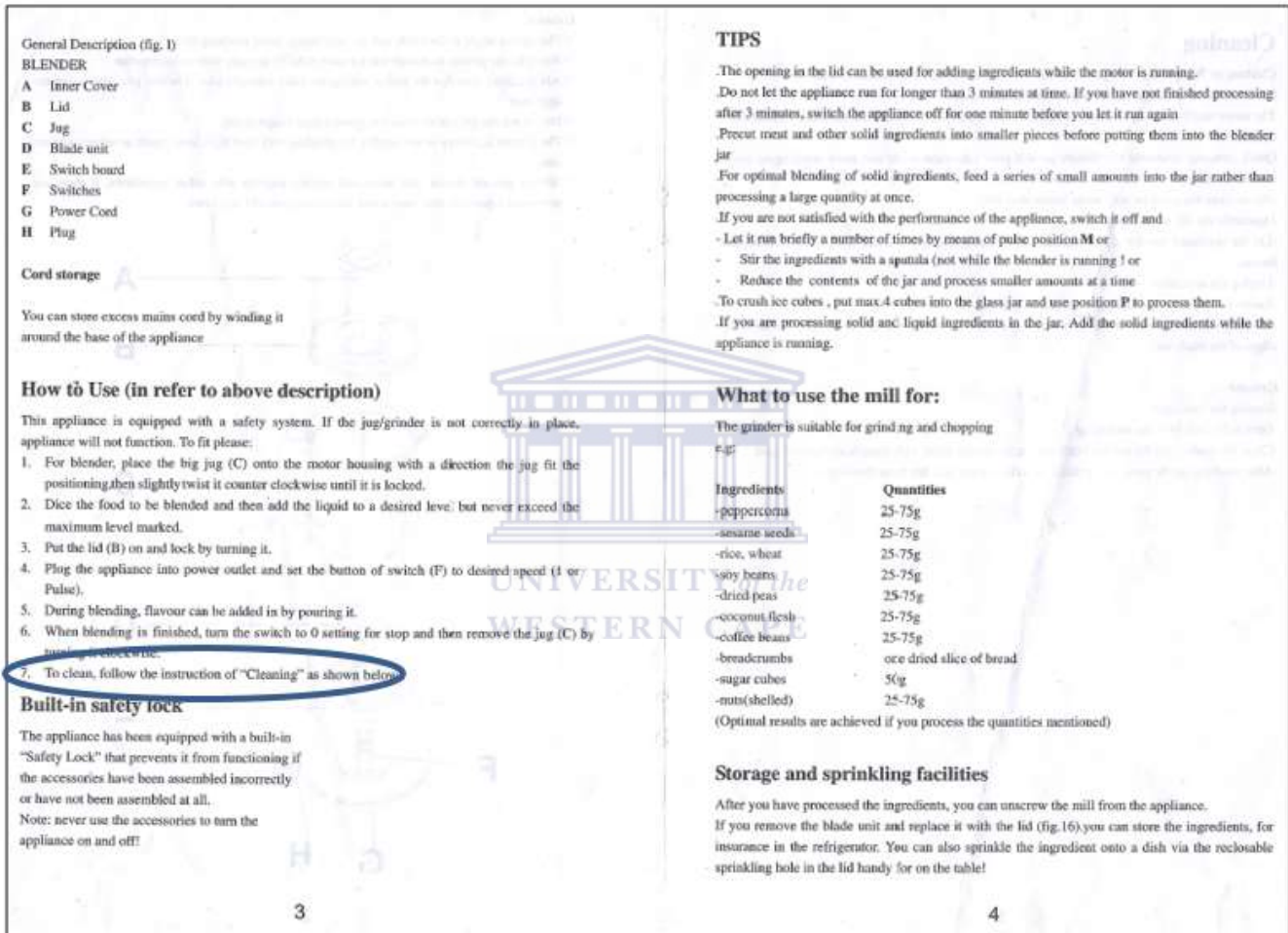

**Figure 37: An excerpt of the instruction which was used as a basis for a question addressing the issue of placement of information, as well as genre of manuals.**

This instruction (as circled in figure 37) indicated to the reader that s/he should “follow the instruction of ‘Cleaning’ as shown below”. However, when examining the excerpt, there is no cleaning instruction or information provided to the reader. This once again shows that the placement of information is either incorrect, or that the writer of the manual provided the incorrect instruction at the incorrect place within the manual.

The following question was then presented to the participant: “Where in the manual is the information on ‘Cleaning?’” Of the 20 (87%) participants who answered the question, 19 (83%) correctly stated “on page 5” with 1 participant indicating that the information is “at the back of the manual”. When asked whether this information regarding the cleaning of the product was where they had expected it to be, all 20 participants answered “no”.

Question 12 related to whether or not information supplied in the manual was easy to read and understand, and whether or not the action could be carried out after reading the instruction. An example was taken from the manual and participants were asked whether or not the information was clearly explained. The question was presented as follows:

12. Read the following passage from the manual and answer the question that follows:

I. For blender, place the big jug (C) onto the motor housing with a direction the jug fit the positioning, then slightly twist it counter clockwise until it is locked.

Figure 38: An excerpt of an instruction as used in the question 12 to address the issue of plain information and readability.

With 2 participants not answering the question, 15 (65%) participants answered that the instruction was not clear, which could point to the possibility that they would have difficulty assembling the jug on the motor housing, as this is what is required in the instruction above. The remaining 6 (26%) participants indicated that they thought the instruction was clear. Consumer confidence is hampered when users are not able to complete a task that is expected of them (Schmitz, 2007), resulting in a form of disempowerment as well as the reluctance to read a product manual (Eiriksdottir & Catrambone, 2011).

### 5.2.3 A brief summary of the Logik manual findings

In conclusion, we find that the Logik manual is a rather complex document to understand fully. One has to carefully decipher what each instruction requests from the user and if, in actual fact, it is stated in the correct order. From the comments of participants who answered the questionnaire based on the Logik manual instructions, the majority found the manual to be incomplete and



missing in information. This creates a basis for insecurity, distrust and lack of confidence – characteristics which a brand would want to avoid at all costs.

When participants were given the opportunity to provide general comments regarding the Logik manual in the questionnaires administered to them, their responses (of those who wanted to provide a general comment) were as follows:

- *“Understandable.”*
- *“It’s understandable.”*
- *“It’s okay.”*
- *“Descriptions are below expected standard (for an English speaking/reading person) and related information should be easily accessible.”*
- *“The instructions are unclear. It uses a lot of personification which can be confusing. The instructions are not in logical order. The sketch is not labelled clearly.”*
- *“It’s very confusing and the parts of the blender are not labelled properly.”*
- *“Confusing in certain areas. Wrong descriptions of parts. Multiple names for certain parts.”*

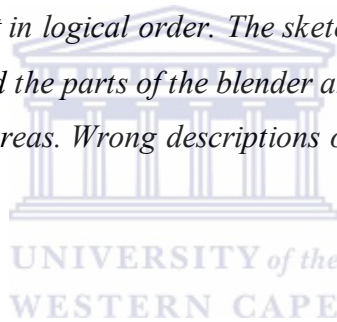

## **5.3 Ottimo Manual Questionnaire Interpretations**

### **5.3.1 Introduction**

The questions relating to the Ottimo manual were based on instructions taken from the manual. A similar structure and range of questions as that of the Logik manual questionnaire underpinned the questionnaire. The questions were asked to test whether or not consumers understood what they read, what they were meant to do and if they could identify the various product parts as referred to in the manual. Questions were also asked to get a sense of how consumers felt towards reading the manual and respondents were given the opportunity of answering closed and/or open-ended questions. The following section is an account of all the responses to the Ottimo manual questionnaire.

### **5.3.2 An Account of Responses to the Ottimo Manual Questionnaire**

Questions 1 and 2 of the questionnaire related to the various parts of the kitchen blender and questions were asked based on whether or not the participants were able to identify and label product parts from an unlabelled image of the product. This was an issue of multimodality but also of consistency in the use of terminology. The questions read as follows:

1. *In figure 1<sup>13</sup> taken from page 3 of the Ottimo manual, do the following where possible:*



***Figure 1***

---

<sup>13</sup> For the purpose of the questionnaire, the Ottimo kitchen blender was marked as *Figure 1* as a guideline to answer the question.

1.1 Identify and label the part “knob” by drawing an arrow pointing away from the image and writing “knob” at the tip of the arrow.

1.2 Identify and label the part “lid” by drawing an arrow pointing away from the image and writing “lid” at the tip of the arrow.

1.3 Was this a difficult or confusing task?

- Yes
- No

2. Still, by looking at the figure above, which of the following parts can you identify? Use an arrow to show each part and write the name of the part by the tip of the arrow pointing away from the image:

-blender

-motor assembly

-blending jar

-motor

-jar

2.1 Was this a difficult or confusing task?

- Yes
- No



Combining the results for both questions, we obtain table 15 below.

	<b>CORRECTLY IDENTIFIED</b>	<b>INCORRECTLY IDENTIFIED</b>	<b>DID NOT ANSWER</b>
<b>1. 'KNOB'</b>	23 (100%)	0	0
<b>2. 'LID'</b>	23 (100%)	0	0
<b>3. 'BLENDER'</b>	4 (17%)	9 (39%)	10 (44%)
<b>4. 'MOTOR ASSEMBLY'</b>	14 (61%)	0	9 (39%)
<b>5. 'BLENDING JAR'</b>	16 (70%)	0	7 (30%)
<b>6. 'MOTOR'</b>	12 (52%)	0	11 (48%)
<b>7. 'JAR'</b>	11 (48%)	0	12 (52%)
<b>TOTAL</b>	103	9	49

**Table 15: Answers to questions 1 and 2 relating to identifying product parts.**

As seen in table 15, questions 1 and 2 resulted in participants correctly identifying the majority of parts, recording a total of 103 correctly identified parts altogether compared to only a total of 9 incorrectly identified parts. Compared to that of the Logik manual, the above figures show that users seemed to easily identify the parts in the Ottimo manual. Many participants didn't indicate where the "motor" or "jar" was because they felt that it referred to the same part as "motor assembly" and "blending jar" respectively (notes of these were made on their questionnaires).

When asked whether the above question, relating to identifying the various product parts, was difficult or confusing, all the participants except 3 indicated that this was not a difficult or confusing task. Of the participants who indicated that the task was difficult or confusing, their reasons for stating so was: "There are 2 lids!" and "Not sure which is blending jar or jar". In summary, it seemed that many of the concerns around image-text relations and the use of terminology in the Logik manual which produced a higher number of incorrect answers in the corresponding questionnaire, were not arising for respondents of the Ottimo questionnaire. These results for the Ottimo questionnaire confirm the theoretical analytical findings in Chapter 4.

Question 3 of the questionnaire sought to identify whether participants could distinguish between what was referred to as a “unit” and what was referred to as an “appliance” in the various instructions throughout the manual. This was an issue of consistency in the use of terminology. The question read as follows:

3. Read the following passages from the manual that mention the word “unit” and using figure 2<sup>14</sup> below as a guideline, answer the questions that follow:

A:

- Never immerse the unit in water or any other liquid for cleaning purposes.

B:

- Always operate the appliance on a smooth, even and stable surface. Do not place the unit on a hot surface.

C:

- Do not leave this appliance unattended during use. Always unplug the unit when not in use or before cleaning.



**Figure 2**

3.1 In figure 2, taken from page 2 of the Ottimo manual, what does “unit” in text A above refer to? Draw a line which you label “unit in A” to point to the unit referred to in the image above.

3.2 Again in figure 2, what does “unit” in text B above refer to? Draw a line which you label “unit in B” to point to the unit referred to in the image above.

---

<sup>14</sup> For the purpose of the questionnaire, the Ottimo kitchen blender was marked as Figure 2 as a guideline to answer the question.

3.3 Still referring to figure 2, what does “unit” in text C above refer to? Draw a line which you label “unit in C” to point to the unit referred to in the image.

3.4. Was this a difficult or confusing task?

- Yes
- No

Table 16 presents the results.

	<b>CORRECTLY IDENTIFIED</b>	<b>INCORRECTLY IDENTIFIED</b>	<b>DID NOT ANSWER</b>
<b>3.1 Unit in A</b>	12 (52%)	7 (30%)	4 (17%)
<b>3.2 Unit in B</b>	14 (61%)	6 (26%)	3 (13%)
<b>3.3 Unit in C</b>	14 (61%)	6 (26%)	3 (13%)
<b>TOTAL</b>	40	19	10

**Table 16: Answers to question 3 relating to terminological inconsistency and identification of parts.**

As table 16 shows, of all 23 participants who answered the question, a total of 40 parts were correctly identified, 19 parts were incorrectly identified and a remaining 10 parts were unaccounted for. The word “unit” as used in A, B and C, referred to the motor assembly which is the section that ‘power-operates’ the blending jug.

When analysing the manual instructions that formed the basis of question 3, the word “unit” as referred to in instruction A, refers to the motor assembly, because the blending jug and its parts can all be submerged in water, the motor assembly cannot. In B, the “unit” refers to the motor assembly as well and the word “appliance” refers to the entire (assembled) kitchen blender. In C, the “unit” refers to the motor assembly, as this is the part that operates with electricity (power). Of the 23 participants who examined the question, 5 (22%) indicated that the task was difficult or confusing and 4 (17%) participants didn’t answer the question. The remaining 14 (61%) participants indicated that the task was relatively easy to accomplish and therefore answered “no” the task was not confusing or difficult.

From these variations we find that in the case of the Ottimo manual, misperceptions were not somewhat of a hassle and this is indicated by the 40 correct identifications compared to the 19 incorrect identifications. Participants who answered the Ottimo manual questions seem to have made further sense of the instruction with the help of further information in the sentence.

Question 4 took into account the use of images and text and how the two can accompany each other to achieve a greater result (Schriver, 1997). The participants were asked whether or not a given set of instructions was clearly explained and were asked to provide a reason for their answer. The question read as follows:

4. Read the following passage from the manual and answer the question that follows:

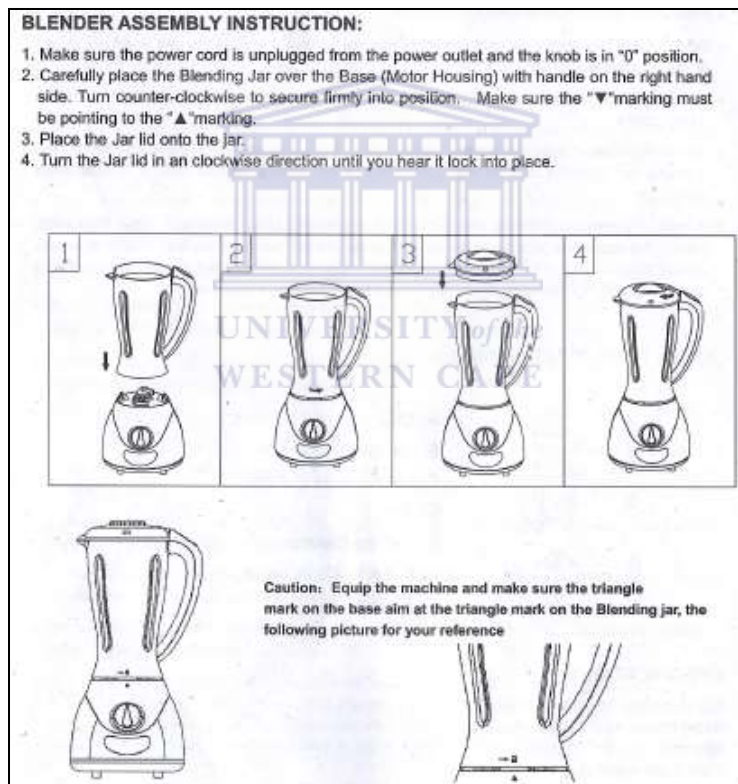

4.1 Do you think these instructions are clearly explained?

- Yes
- No

4.2 Briefly explain your answer:

.....

22 participants agreed that the instructions were clearly understandable. Some of their answers for stating this were as follows:

- *“It tells you step-by-step what to do.”*
- *“The language used to explain the instructions do not contain jargon and it’s in plain, simple, understandable language for the average person.”*
- *“Together with the instruction a picture is shown to support the instruction.”*
- *“Indications are clearly marked and explained.”*
- *“The instructions were short and to the point, also easy to understand.”*
- *“I think it is clearly explained because everything is marked properly.”*
- *“It is giving a step-by-step guide as to what needs to be done.”*

The one respondent who indicated that the instruction was not clearly explained, stated that within each instruction, there were 2 or 3 minor instructions on what had to be done and therefore the images did not accompany each of the 4 instructions clearly. For example instruction 2 read as follows:

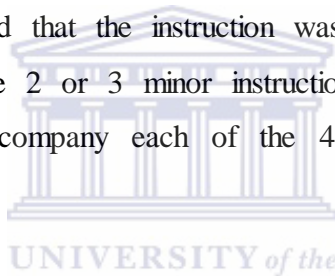

*“Carefully place the Blending Jar over the Base (Motor Housing) with handle on the right hand side. Turn counter-clockwise to secure firmly into position. Make sure the "▲" marking must be pointing to the "▼" marking.”*

The participant therefore understood each sentence to be an individual instruction to which there are no additional accompanying images displaying these various in-between actions.

In his guide to developing consumer product instructions, Smith (2003: 23) suggests that “when possible, each step should describe a single action because a long list or continuous paragraph of steps is undesirable because users can lose their place easily and have difficulty understanding how each step fits in the overall task.” In order for this participant’s understanding of the instructions to go from “difficult” to “relatively easy”, an image designed for each action will make reading easier.



Question 5 tested whether participants would correctly identify parts in the manual. It would be recalled from the Logik manual that, because the actual names of product parts labelled A-H were on a different page from the image, the effort in identifying parts was relatively considerable. In the Ottimo manual, however, as seen in figure 39, actual names and alphabetical representations appear in the same space as the image.

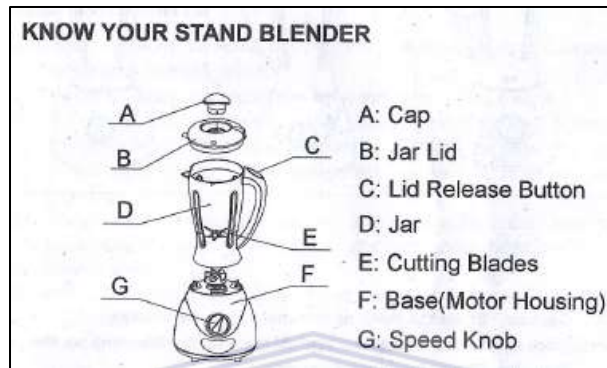

**Figure 39: An image of the exploded view of the Ottimo manual.**

In question 5, the respondents were presented with a version of figure 39 but without the product names, and the purpose was to find out if respondents could identify two parts (speed knob and cap) by referring to the manual. Question 5 read as follows:

5. Study figure 3<sup>15</sup> below (taken from page 2 of the Ottimo manual), then answer the questions that follow:

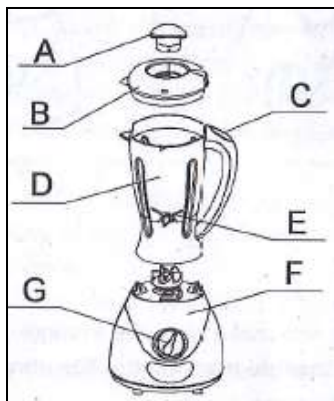

**Figure 3**

5.1 Identify the speed knob by writing SK close to the letter representing the speed knob.

<sup>15</sup> For the purpose of the questionnaire, the Ottimo kitchen blender was marked as *Figure 3* as a guideline to answer the question.

5.2 How did you find the answer in **the manual**? Explain:

.....

5.3 Identify the cap by writing CP close to the letter representing the cap.

5.4 How did you find the answer in **the manual**? Explain:

.....

All 23 participants correctly identified the parts by consulting the manual, which clearly marked the various parts of the kitchen blender with their accompanied names next to the image. The manual reflects the point made by Backinger and Kingsley (1993) that manuals in which images and text appear together read well. They stated that graphics need to be placed next to their corresponding texts to achieve easier reading and understanding (1993: 41).

Question 6 was an issue of consistency/variation in the use of terminology (blade, blender blade, blades, cutting blade). The question read as follows:

6. Read the following passages taken from the manual and using figure 4<sup>16</sup> below as a guideline, answer the questions that follow:

4. Don't misuse the appliance. Handle the blade with care: it is very sharp.

9. **Caution: Use extreme care when handling the Blender blade. Do not touch blades with your fingers. The Blades are very sharp and can cause injury if touched.**



**Figure 4**

---

<sup>16</sup> For the purpose of the questionnaire, the Ottimo kitchen blender was marked as *Figure 4* as a guideline to answer the question.

6.1 Using figure 4 above, taken from page 2 of the *Ottimo* manual, identify the following parts by labelling them. Use an arrow to show each part and write the name of the part by the tip of the arrow pointing away from the image:

- Blade

- Blender blade

- Blades

6.2 Was this a difficult or confusing task?

- Yes
- No

6.3 Briefly explain:

.....

Of the 23 participants who answered the question, 16 (70%) participants were able to identify blades, blender blade and blade as the same part as cutting blades (part E in the labelled image associated with question 5). However, 7 (30%) participants marked the following circled part (in the image in figure 40 below) as the blender blade and blade:

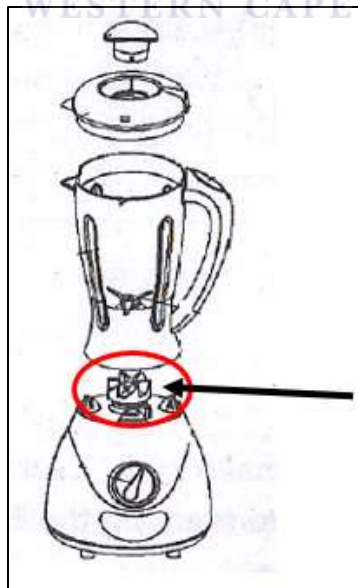

**Figure 40: An indication of the part participants confused as being the “blender blade” or “blade”.**

This is rather problematic because it means that in assembling the product, the user may not be clear as to what part is actually referred to in the instruction as the blender blade or blade. When it comes to word choice and consistency, Backinger and Kingsley (1993: 27) strictly state that manual writers need to use the same term to identify a device and its parts and to avoid using synonyms or alternate phrases. By simply looking at the actions required to assemble the blender, one cannot place the blades between the jug and the base. This would result in the blades being on the outside of the blender instead of being on the inside of the jug.

When asked whether the participants found this task difficult or confusing, of those who answered, 6 (26%) participants stated that “no” the task was not difficult or confusing because: *“the blades are situated in the blender; each part mentioned refers to one part; the picture shows you”*. The remaining 17 (74%) participants argued that the task was confusing or difficult. Some of their reasons for stating this was as follows:

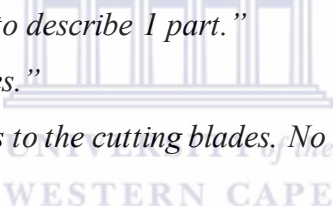
- 
- *“3 different terms used to describe 1 part.”*
  - *“Couldn’t find the blades.”*
  - *“The manual only refers to the cutting blades. No specifications regarding other blades.”*
  - *“Page 2 of the manual only gives cutting blades and not blades. There is no blender blade indicated on page 2 of the manual.”*
  - *“The blade/blades are referred to as cutting blades on page 2. It should be referred to as cutting blades throughout the manual.”*
  - *“Blade, blender blade and blades were what we had to identify, but in the manual only the cutting blades is identified.”*
  - *“It was confusing because there was only one set of blades.”*

The results to the above question also confirms the study conducted by Novick and Ward (2006), in which they found that their participants felt frustrated by not finding information because the terms and keywords used failed to match their vocabulary.

Question 7 looked at whether or not the participants could understand what was meant by the voltage information supplied in the manual and whether or not they could explain this to someone else if this was expected. The question read as follows:

*7. Read the following passages taken from the Ottimo manual and answer the questions that follow:*

- Always ensure that the voltage on the rating label corresponds to the voltage in your home.

#### **SPECIFICATIONS**

Rated voltage: AC 220-240V 50Hz  
Rated Power: 400W  
KB=1min  
Cord: 2-pin round plug

*7.1 Can you explain what the manual asks you to do about the “voltage in your home”?*

- Yes
- No

*7.2 Do you think the specifications above are clearly explained?*

- Yes
- No



Of all (23) the participants who answered the question, 14 (61%) said “yes” they understood what was meant by the above instruction. The remaining 9 (39%) participants indicated “no” they did not understand what was meant by this instruction. As would be expected, the participants who indicated that the instruction was understandable also indicated that the specifications were clearly explained. The same pattern was observed with those who indicated that the instruction was not clearly understood – stating that the specifications listed were not clearly explained.

Questions 8 and 9 required respondents to comment on the way that instructions were written, whether they were clearly understood and whether or not any errors in the instructions hindered the participants’ understanding. The following individual instructions, taken from the manual, were given as examples and participants were only required to read through them and indicate, by ticking “yes” or “no” in the questionnaire, whether these instructions were clearly explained

and whether or not any errors (noticed) would hinder their action in completing what was required.

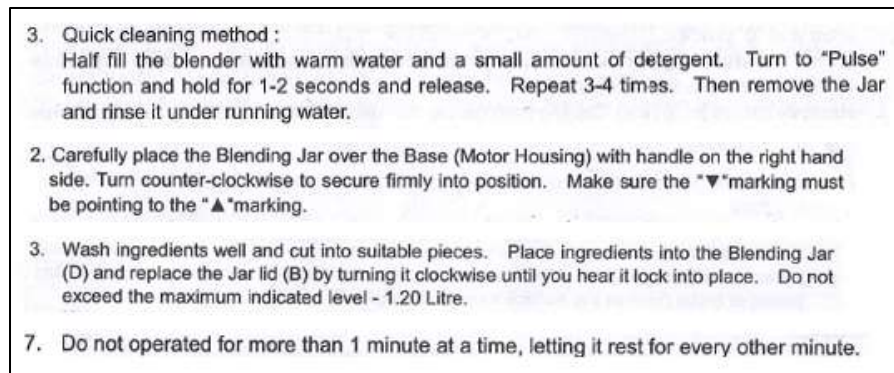

**Figure 41: An excerpt of instructions in the Ottimo manual used as basis for question 8 and 9.**

The participants' reactions were as follows: 21 (91%) participants indicated that the instructions were easily understood and that there were no errors (noticed) that would hinder their actions. 2 (9%) participants different in opinion and indicated that the instructions were not clear. The reasons provided by the two were as follows: *"words such as 'small amounts' and 'suitable pieces' can be confusing. Small amounts and suitable pieces have different sizes depending from person to person"* and *"the instructions are loaded with too much information."*

### **5.3.3 A brief summary of the Ottimo manual findings**

To conclude the Ottimo manual questionnaire, the general feeling around the manual is that it is comprehensive. It is clear in the sense that users know what to do and when to do it; and to most, it is understandable and easy to follow. Participants were given the opportunity to provide general comments regarding the Ottimo manual, and the responses (of those who wanted to provide a general comment) were as follows:

- *"The instructions in the manual is fair enough to understand. The pictures however could be clearer."*
- *"Manual is a little confusing. For example, there are 2 lids."*
- *"Clear instructions and details are provided for use."*
- *"Explanations are clear and good descriptions."*

- *“Instructions are clear. More information regarding the different blades are required.”*
- *“Only 6 pages which is great. If there were more pages, I wouldn’t even bother to look at it. There’s no index though, so that isn’t good.”*
- *“The manual was not that clear to read and understand.”*

### 5.3.4 Conclusion

The findings from the questionnaire analysis suggest that the Ottimo manual supported information retrieval and processing better than the Logik manual. If we compare, for example, questionnaire items for both manuals that required parts to be identified, we obtain the following picture:

Identification task in the Logik questionnaire	Total correct answers	Identification task in the Ottimo questionnaire	Total correct answers
Questions 1 and 2	84	Questions 1 and 2	103
Question 3	36	Question 3	40
Question 5	20	Question 5	46
Question 8	14	Question 6	16
<b>Total</b>	<b>154</b>	<b>Total</b>	<b>205</b>

**Table 17: a breakdown of correct identified parts between the Logik and Ottimo manual.**

Table 17 shows that, on comparable tasks around identifying parts of the product, the performance of the Ottimo manual respondents was better than that of Logik manual respondents. This also confirms the results of the theoretical analysis in Chapter 4.

In the next chapter, we will further seek to triangulate the findings by using task-performance data.

## 5.4 FINDINGS BASED ON AN ANALYSIS OF TASK PERFORMANCE (VIDEO CLIPS)

### 5.4.1 Introduction

Among other methods of assessing product manuals, it would be recalled that Woolever (1999: 248) had underscored the importance of “informal observations” of people’s use of manuals in task execution. These observations were seen to “yield more qualitative than quantitative results”. This section, then, presents a narrative based on video frames of how a few respondents assembled the blender assigned to them. Assembling the blender was the task given to the respondents, and in part the data is relevant to the objective on how typical or potential product owners use the manuals to carry out specific tasks on a product. It will also contribute to the objective around contributing a South African perspective to the international discussion on product users’ attitudes to manuals

With these statements and findings in mind, I now analyse the extent to which possible users of kitchen blenders were able to assemble the Ottimo and Logik kitchen blenders individually using the resources at their disposal, that is, their individual manuals. The instruction given to participants was: *“Use the manual in assembling the product.”*



**Participant 1.** In the series of clips in figure 42 below, we find participant 1, a female in her 30s, removing the various parts of the Ottimo product from its packaging.

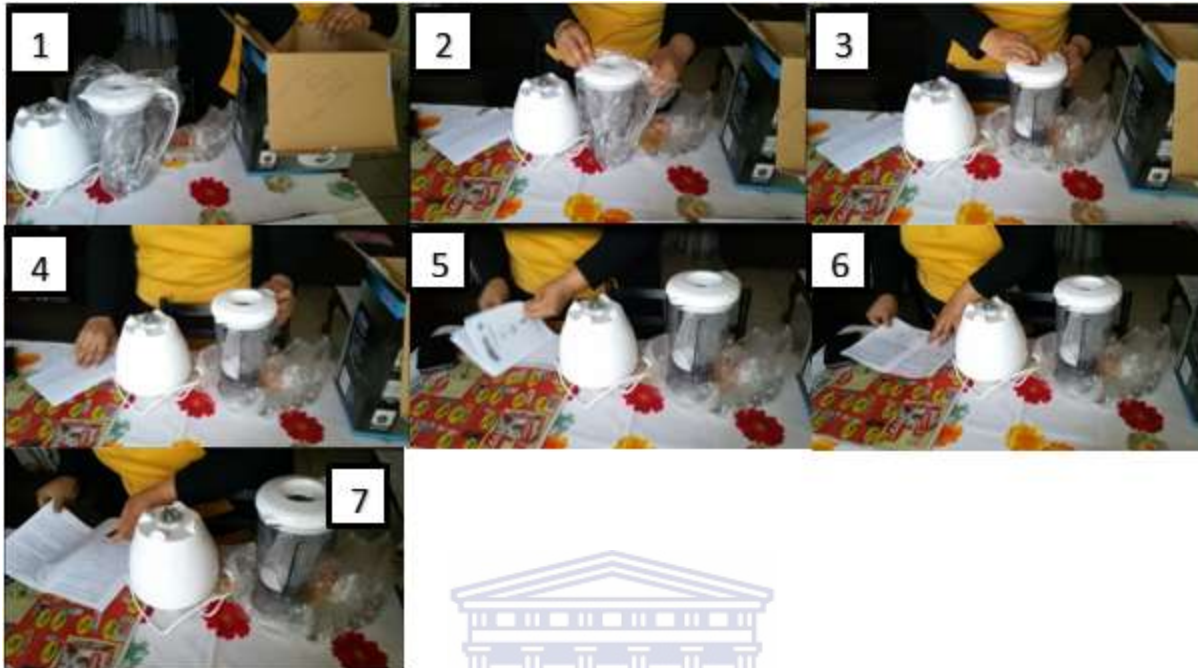

**Figure 42: Participant 1 unpacking Ottimo blender.**

The participant removes the product parts from its packaging (in frames 1-3) and at 00:36 seconds, the participant consults the manual (from frames 4-7), only skimming through, trying to familiarise herself with the most important parts and sections needed to complete the task. She remains quiet as she seeks assembling information or images that will assist her in assembling the blender. The participant swiftly pages through the manual trying to find this sort of information. She does so from 36 – 55 seconds (frames 4-7), but still does not seem to find what she is looking for. This confirms Mehlenbacher’s (2003) statement that “few users read all the support materials; rather, they search for particular headings, information items, or procedures.”

The long narrative that follows shows how information that is contained in the manual may not be retrieved easily, which raises the question as to whether the blame is to be placed on a ‘careless’ reader or (also) on the manual author who did not factor in reader ‘haste/carelessness’ in document design. In the next series of frames (figure 43), we see how the participant first tries to remove the lid from the jug before placing it on the motor housing. The participant attempts to do this because of the product parts that are in the jug and have to be removed before use.

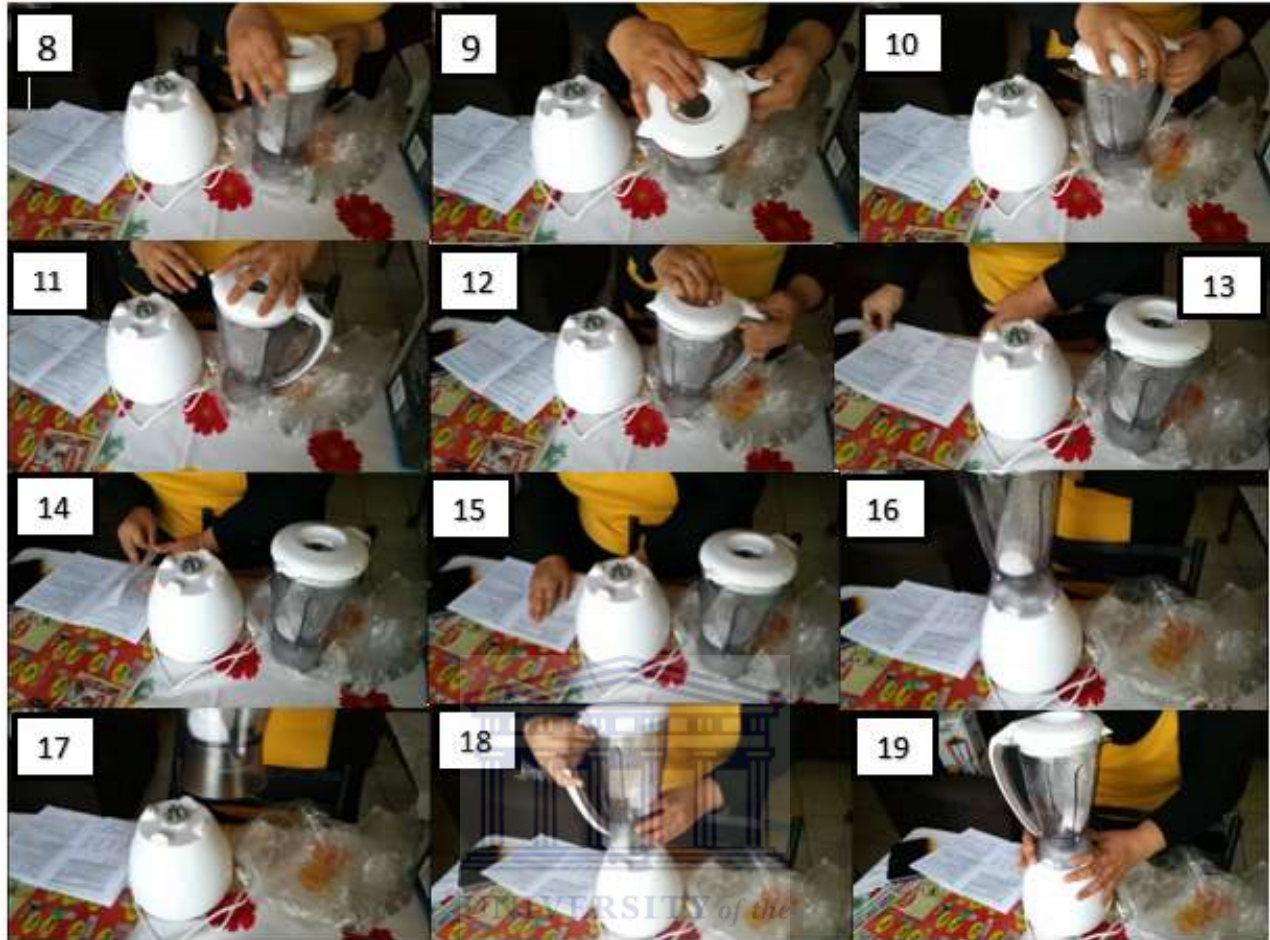

**Figure 43: Participant 1 attempting to remove lid from jug**

From 00:57 seconds to 01:31 minutes (that is, frames 8-12), the participant tries to remove the lid from the jug. Not having been successful, she consults the manual again from 01:32 – 02:00 minutes (that is, frames 13-15), skimming through the pages to find relevant information to assist her in removing the lid successfully. As seen in the frames 13-15 in figure 43, the participant turns the pages from pages 1-2, 2-3, and 3-4 as she continues searching. After trying to find the relevant information (apparently without much luck), the participant then turns to fitting the jug on the motor housing (frames 16-18). After turning the jug in all directions on the motor housing, in an attempt to securely fit it, she locks the jug in place at 02:28 minutes (frame 19), and then again consults the manual to assist in removing the lid from the jug (as seen in the following set of frames, frame 20). For a further 25 seconds participant 1 pages through the manual in the hopes of finding information that will explain how the lid should be removed. Thereafter, she is seen struggling to remove the lid from the jar again.

In the series of frames in figure 44, we see her place her fingers in the opening in the lid (frames 20-23), in an attempt to lift the lid off and also to remove the parts in the jug, but after struggling for a while, the participant consults the manual again and now reads carefully to find the section(s) which might explain how the lid should be removed (frames 26-27).



**Figure 44: Participant 1 still trying to remove the lid from the jug.**

After 4 minutes one can now hear the participant trying to make sense of the various individual parts. She is also heard saying in Afrikaans “*Daai is die lid release button*” which, translated to English, means “*That is the lid release button*”, and further explains on video that when she presses the button, it does not release the lid. Participant 1 is then seen forcefully trying to remove the lid from the jug at 04:40 minutes until 05:05 minutes (frames 28-30) where she asked someone to assist her.

The participant's assistant then tries to remove it by pressing in the release button on the handle and tries lifting the lid whilst participant 1 tries to locate the information in the manual once again. This is seen in frames 31-35. After a further 2 minutes of struggling, the pair are still trying to remove this part in order to get to the various smaller product parts which are stored in the jug.

Next we see how participant 1 acquaints herself with the blender product by mentioning the various parts according to their descriptions in the manual (seen in frames 36-38). She therefore begins to do what one would expect users to do before they assemble and use a product. This is documented in figure 45 below.



Figure 45: Change of reading strategy to support solving the problem of removing lid.

Participant 1 then goes on further to read an instruction on page 4, under the heading “*To use your stand blender*”. It reads as follows, “*Remove the Jar lid (B) with Cap (A) from the Blending Jar (D) by pressing the Lid release button (C) on the handle and turning the Jar lid counter-clockwise*”.



**Figure 46: The new reading strategy leads to a breakthrough.**

As she reads it aloud to her assistant, showing her male assistant the marked parts as in the instruction (frames 39-41), she stops midway and exclaims “*Aaaha!*” after reading that the button should be pressed in and the lid should be turned in a specific direction in order for it to be released from the jug. This also proves that using headings and clear statements of “how to use” specific parts of the blender, makes finding information easier (Mehlenbacher 2003).

The participant and her assistant successfully remove the lid from the jar at 06:59 minutes and are then seen removing the part from the jug and placing it in the lid. This is seen in frames 45-51 in figure 47. The blender was fully assembled in 7:23 minutes.



**Figure 47: Problem of removing the lid from jug finally solved.**

This example of removing the lid from the jug points to two issues. Firstly, like product users elsewhere in the world, the South African users in this study do not ‘study’ manuals first before using the corresponding product. As has been documented in the literature (Novick & Ward,

2006; Jansen & Bilijon, 2002; Freeman, 2003; Mehlenbacher, 2003), product users typically consult the manual only when they have been unable to intuitively use the product. Secondly, this example raises questions about the quality of the manual that could not have been revealed from the analyses in the previous two chapters. While participant 1 did not start off (removing the lid from the jug) by reading the manual, we see that on several occasions she did consult the manual, but did not appear to find the section relevant to this particular problem. The information simply did not ‘jump out’ at her. When she eventually ‘studied’ the manual, she found the information under what is obviously an unexpected heading, “*To use your stand blender*”. Speculatively, this heading may have initially communicated to her that the information in the section was on operating the blender, rather than on assembling it.

Let us now turn to the second participant attempting to assemble the Ottimo blender.

**Participant 2.** In the video frames in figure 48, a middle-aged male is seen attempting to assemble the Ottimo manual blender. He removes it from its packaging (as seen in frames 1-3) and attempts his task.

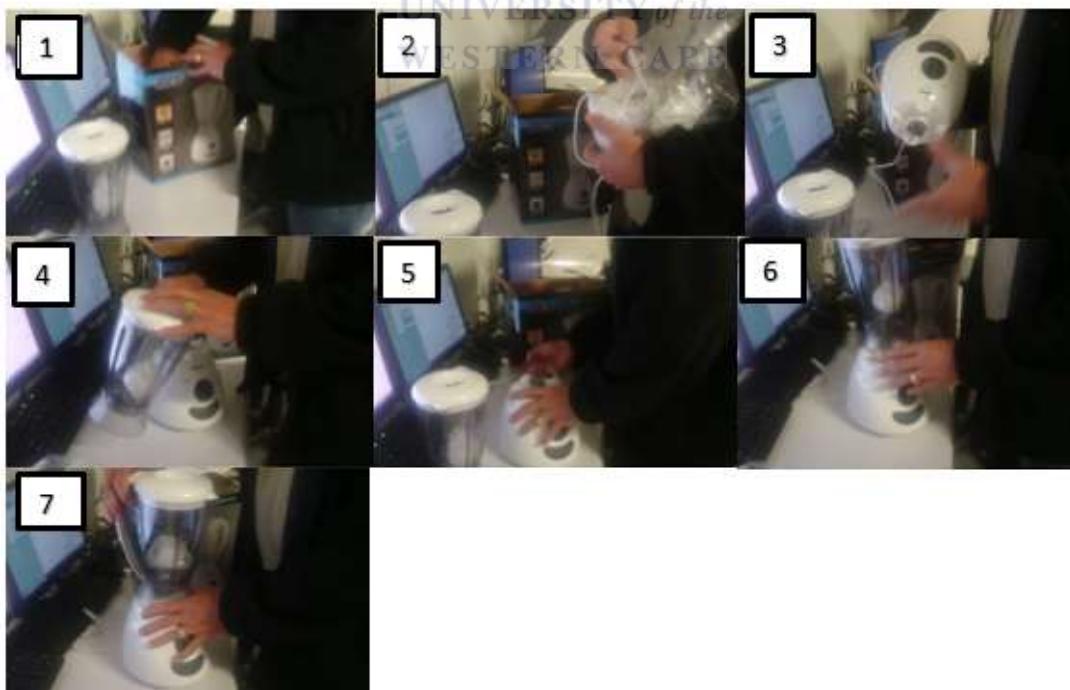

Figure 48: Participant 2 begins task of assembling blender.

In the first few frames (frames 5-7), we see the male participant first trying to place the jug onto the motor housing. Note that there is no manual in sight. This could either be because the participant is not interested in reading the manual, or as Mehlenbacher *et al* (2002: 733) states, the user is often impatient and wants to get productive, which is highly the case.

As he tries securing the jug onto the motor housing, he is seen turning the jug in a 180-degree angle, with the expectation of it locking into place (as seen in frames 6 and 7 in figure 48). At 00:38 seconds he lifts the jug to examine the bottom before attempting again (as seen in frames 8 and 9 in figure 49). After the second attempt, and at 00:53 seconds, participant 2 secures the jug onto the motor housing (frame 13). In frame 14, he is seen trying to remove the lid from the jug. This was the same difficult task participant 1 had. Figure 49 captures further attempts in this connection.

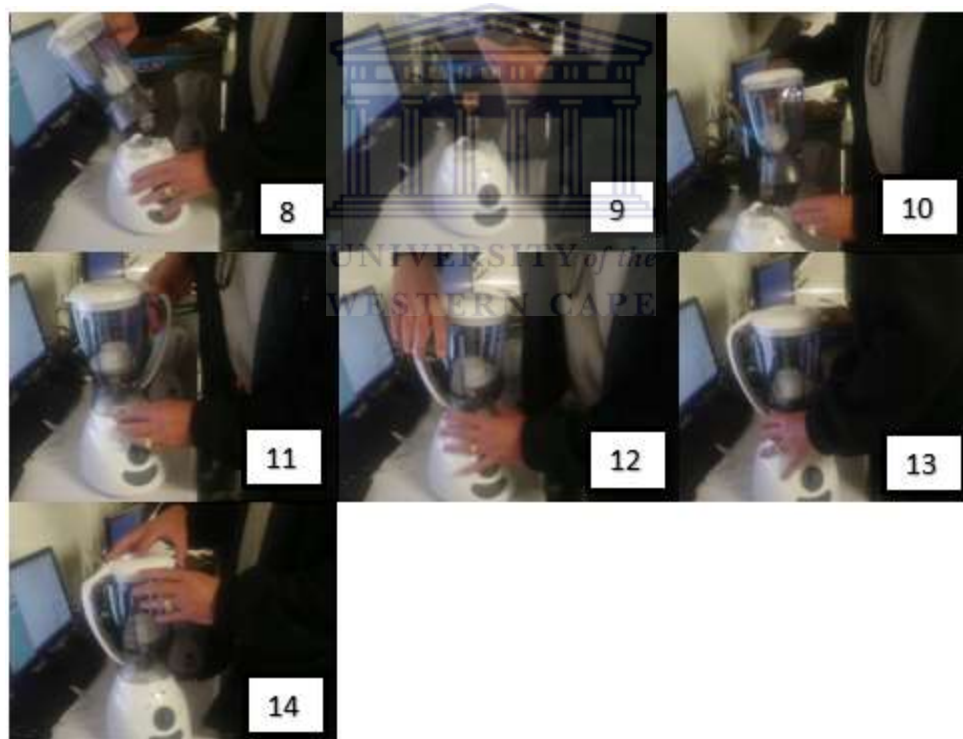

Figure 49: Participant 2 attempts to remove the lid from the jug.

When listening to the video recording of the second participant, one can hear the click noises as the participant lifts the lid and continuously presses the release button expecting the lid to easily come off. This is seen in frames 15-17 in figure 50. At 01:15 minutes participant 2 becomes annoyed at the fruitless attempts and steps back saying in a cynical tone, “*Oh, like so!*”.



**Figure 50: Participant 2 struggles to remove the lid whilst pressing the lid release button.**

At 01:37 minutes he is heard saying “*Why can’t I get this thing open?*” referring to the lid, and thereafter states “*It’s probably broken already.*”

In figure 51 below, participant 2 is seen removing the jug from the motor housing and attempting again to remove the lid from the jug. We see this attempt in frames 22-25. After trying to lift the lid in all positions, he then places the parts back in their packaging and into the box. See frames 27-29 in figure 51.



**Figure 51: Participant 2 gives up trying and repackages the blender.**



Participant 2 finishes his (unsuccessful) attempted task within 01:39 minutes. This confirms Novick and Ward's (2006) claim that when people feel a sense of irritability, even when they are not using the manual, they may just give up trying.

A particularly difficult task, whether or not the manual was consulted, was removing the lid from the jug. All of the recordings show that participants felt this was a task that could be accomplished intuitively. This turned out not to be the case, and from this observation questions about the very design of the blender may be asked, not just the manual. In the case of the manual, although it contained the relevant information, we see it was not apparent that it was contained in the section in which it was eventually found. Given the several unsuccessful attempts at finding the relevant information in the manual, one wonders whether the manual is not in breach of the CPA provision on understanding “*without undue effort, having regard to—[...] (d) the use of any illustrations, examples, headings or other aids to reading and understanding.*” Let us now turn to the Logik manual and participant 3

**Participant 3.** This female participant is in her early 20s and is attempting to assemble the Logik blender. See figure 52.



**Figure 52: Participant 3 begins the assembling task.**

As the video frames in figure 52 suggest, after removing the parts from its packaging, participant 3 reaches for the manual and calls out each part in order to familiarise herself with the product (as seen in frames 1-5). After removing the parts which were packaged inside the jug, the participant easily places the jug onto the switch board as seen in frames 6-9 in figure 53.



**Figure 53: Participant 3 successfully places the jug onto the switch board.**

She then takes the inner cover, and not certain which side it should be inserted into the lid, tries inserting it both from the exterior and interior side of the lid, after which she gives up, picks up the grinder and refers back to the manual for some further explanation. These attempts are seen throughout frames 10-16 in figure 54 below.



**Figure 54: Participant 3 is uncertain about the assembly of a specific product part and turns to the manual for further assistance.**

After inserting the lid back onto the jug at 03:09 minutes (frame 14), the participant is heard saying “*It doesn’t say where the inner cover must go...*” and “*It says nothing of the inner cover,*

*so I'm not going to touch the inner cover.*” It would be recalled from the analysis of user experiences in chapter 5 (table 7) that, in the Logik manual, the part ‘inner cover’ was the one that posed the most problem of identification to respondents. We see that apparent problem resurfacing here in this usability test.

#### **5.4.2 A summary of the performance task findings**

The relevance of the task performance to an analysis of the manuals turned out to be rather limited precisely because participants, like product users elsewhere, tend not to consult manuals.

Based on the recordings, a common thread was that participants removed all the parts within the packaging, but only removed and consulted the manual at a later stage throughout their task, when they were faced with some difficulty. Mehlenbacher (2003) reminds us that most users of products are rushed, frustrated, task-oriented and frequently are uninterested in reading documentation.

With the example of participant 1, however, we see repeated attempts at reading the manual, yet the particular information of interest is not found, even though it is available. It is interesting that this observation was made in respect of the Ottimo manual, which on the previous analyses seemed to be rather very well produced. As noted earlier, the relevant information was under a heading, *“To use your stand blender”*, which may have been perceived as misleading, or containing information on the actual operation of the blender.

As research has previously shown that less people make use of manuals, or have no interest in consulting them, Ramaker (2007) found that since manufacturers perceive that product users do not spend time reading manuals, they (manufacturers) too tend not to invest resources in producing quality manuals.

## CHAPTER 6

### CONCLUSIONS AND RECOMMENDATIONS

#### 6.0 Summary

The background to this research was provided in part by South Africa's Consumer Protection Act of 2008, which sets out in detail requirements that have to be met by manuals accompanying products and services. Section 22(2) of the CPA states the following:

*(2) “For the purposes of this Act, a notice, document or visual representation is in plain language if it is reasonable to conclude that an ordinary consumer of the class of persons for whom the notice, document or visual representation is intended, with average literacy skills and minimal experience as a consumer of the relevant goods or services, could be expected to understand the content, significance and import of the notice, document or visual representation without **undue effort**, having regard to—*

*(a) the context, **comprehensiveness and consistency** of the notice, document or visual representation;*

*(b) the **organisation, form and style** of the notice, document or visual representation;*

*(c) the **vocabulary, usage and sentence structure** of the notice, document or visual representation; and*

*(d) the use of any **illustrations, examples, headings or other aids to reading and understanding.**”*

With such a detailed set of provisions applicable to product manuals, I considered it necessary to examine some manuals in order to determine how well they conformed to these provisions. I also had a number of other objectives. Specifically, objectives were as follows:

1. To draw on theoretical concepts to evaluate the text of the manuals from the standpoint of their compliance to relevant provisions of the Consumer Protection Act.

2. To obtain users' views on how the semiotic resources employed in the manuals affect the readability and intelligibility of the manual.
3. To determine the extent to which typical or potential product owners can use the manuals to carry out specific tasks with the product.
4. To identify strategies for optimizing or improving the manuals.

Two manuals associated with household kitchen blenders were identified for analysis: the manuals for Logik and Ottimo brand of blenders. The data for answering these questions were from three sources. Firstly, I made use of data from a text analysis of both manuals, using insights from theoretical frameworks inspired by the detailed provisions of the Consumer Protection Act. Secondly, I employed respondents' answers to questionnaires that had been developed on the basis of observations made about the manuals from the theoretical analysis. Thirdly, I observed and video-recorded three respondents who had been instructed to use the manuals to assemble the blender.

With respect to the first objective, I consulted a number of theoretical constructs and literature relating to user manuals, readability measures, terminological consistency, genre, standards of textuality and multimodality. The CPA has provided the basis for these theoretical constructs and when applied, helped determine if the manuals adhered to the standards outlined in the CPA. Which in this case, both the Logik and Ottimo manuals lacked the important aspects as stipulated in the CPA and have therefore not adhered to the standards.

The second objective evoked interesting responses from participants in the form of the administered questionnaires. Both the Ottimo and Logik manuals provide practical information. However, participants liked the Ottimo manual more because it addresses the user, it contains a wealth of information which is clearly marked and retrievable, and so on. Users were quoted stating that the manual was *compact, something they prefer because if it were any longer in terms of the length of pages, they wouldn't bother reading it* – a factor which plays a big role in whether or not users consult manuals today.

The Logik manual, on the other hand, seemed to only be basic, with limited information if the user needed to consult further. With a clearer, larger image and shorter instructions, the manual still did not conform to the users' needs and expectations. They were quoted saying that *although some of the information was understandable, there were certain sections within the manual that were confusing, some instructions did not read well in English* and users didn't understand the general order of information, nor the descriptions provided.

Due to the various shortfalls discussed in Chapter 4, it was evident that information produced in the manuals was decoded in various ways and not entirely based on background information or previous experiences. Furthermore, comments encouraged by questions in the questionnaires produced interesting results relating to the way information was produced in the manuals, including the lack of information in the Logik manual and too much information produced in the Ottimo manual. This leads to the conclusion that neither manual was produced with the requirements of the CPA in mind. As a matter of fact, there were several inconsistencies, errors and a lack of structure in these manuals.

With respect to the third objective, when participants were tasked with assembling the kitchen blender by using the manual, I found that participants removed all the parts within the packaging, but only removed and consulted the manual at a later stage throughout their task, when they were faced with some difficulty. This is in no way surprising, as previous research has shown that fewer and fewer users of products consult their (Carver, 1990; Smith, 2003; Backinger & Kingsley, 1993; Mehlenbacher, 2003). It was also seen that participants experienced difficulty locating basic assembling instructions in the manual. As one may recall from the theoretical constructs and the analyses of questionnaires that the two manuals, and more so the Logik manual, may be in breach of the provisions of the CPA as a result of inconsistent use of terminology, problems of sentence structure, issues of the organisation of information, as well as matters related to illustrations and the labelling of parts.

I will now turn to the fourth objective, that is, recommendations for improving the manuals.

## 6.1 Recommendations for improving the manuals

As this is an academic piece of work, rather than a project commissioned by either manufacturer, the recommendations made here will remain at a generic level. The basis for recommendations is, again, offered by the CPA provisions. In Section 22 of the CPA quoted at the beginning of this chapter, there were a number of issues on which both or one of the manuals defaulted. I have tabulated these issues (refer to table 18), I've shown how a particular manual defaulted and what needs to be done:

*“For the purposes of this Act, a notice, document or visual representation is in plain language if it is reasonable to conclude that an ordinary consumer of the class of persons for whom the notice, document or visual representation is intended, with average literacy skills and minimal experience as a consumer of the relevant goods or services, could be expected to understand the content, significance and import of the notice, document or visual representation without **undue effort**, having regard to—*

*(a) the context, **comprehensiveness and consistency** of the notice, document or visual representation;*

*(b) the **organisation, form and style** of the notice, document or visual representation;*

*(c) the **vocabulary, usage and sentence structure** of the notice, document or visual representation; and*

*(d) the use of any **illustrations**, examples, headings or other aids to reading and understanding.”*

<b>Points as listed in the CPA</b>	<b>Logik manual</b>	<b>Ottimo manual</b>	<b>Recommendations</b>
Consistency	<p>Inconsistency in the use of terms. For example:</p> <ul style="list-style-type: none"> <li>- Switch board, motor unit and motor housing – all synonymous terms used to identify the switch board.</li> <li>- Jug, big jug, blender, blender jug – terms used to identify the jug.</li> <li>- Mill and grinder – inconsistent terms used to refer to the grinder.</li> </ul>	<p>Inconsistency in the use of terms. For example:</p> <ul style="list-style-type: none"> <li>- Electrical appliance, product, machine, stand blender, blender and unit – all terms used to identify the product blender.</li> <li>- Blade, blades and blender blades – all synonymous terms used to identify the part labelled as cutting blades.</li> </ul>	<ul style="list-style-type: none"> <li>- An agreement on terms to be used, and putting in place a controlled language authoring tool that allows only pre-identified terms to be employed or that identifies (flags) certain terms (not previously cleared for use) as not permissible.</li> </ul>
<b>Organisation of information</b>	<p>A better use of frontloading in instructions to determine the action and goal of each instruction and organisation of information is important in ensuring good flow.</p>	<p>Better use of frontloading in instructions to determine the action and goal of each instruction and distinguishing between which instructions perform better with the procedural system.</p>	<ul style="list-style-type: none"> <li>- The implementation of document design where the information enhances accessibility and readability.</li> <li>- Implementation of an authoring environment that requires inputting of instructions according to the goal and action to be taken.</li> <li>- Organising information in a hierarchy of topics to distinguish the importance and sequencing of instructions.</li> <li>- Implementing a mix of procedural, principles and examples in instructions for better comprehension and execution of tasks.</li> </ul>



<b>Points as listed in the CPA</b>	<b>Logik manual</b>	<b>Ottimo manual</b>	<b>Recommendations</b>
<b>Usage/sentence structure</b>	The Logik manual has many errors of grammar, punctuation and language use. Sentences do not make grammatical sense and this contributes to difficulty in reading and applying the instructions correctly.	The Ottimo manual has minimal errors and although the sentence structure is well produced, information is packed and several actions (instructions) are placed in one paragraph, instead of a breakdown of points.	<ul style="list-style-type: none"> <li>- Careful editing which includes producing information in basic sentences as opposed to paragraphs made up of various instructions.</li> <li>- Reconstructing sentences to make reading and understanding easier.</li> </ul>
<b>Illustrations</b>	Although the illustrations in the Logik manual were clear enough to distinguish the different product parts, the grinder image was not included as a 3-dimensional image, and the blender image was not marked. The product parts were also captured on a different page to that of the image.	The Ottimo manual had a good use of image-text relations, but even so, the 3-dimensional image of the blender was rather tiny compared to that of the Logik manual. Images were marked and product parts were displayed next to the image.	<ul style="list-style-type: none"> <li>- A greater awareness of image-text relations as well as placement of images and texts to create less confusion and to minimise time-wasting.</li> <li>- Greater synergy between text and images which will help clarify, simplify and emphasise important issues.</li> </ul>
<b>Headings</b>	Headings were rather misleading in the Logik manual, with some headings possibly having more than one meaning.	The Ottimo manual had headings across all sections in the manual, but even so, they were not worded clearly enough for participants to easily find basic assembling instructions.	<ul style="list-style-type: none"> <li>- Clearly marked headings with information only relating to that specific topic.</li> <li>- Establishing a hierarchy of topics/headings with information grouped into meaningful units.</li> <li>- Maintaining consistency throughout the headings so that users can establish a theme throughout the manual.</li> </ul>

**Table 18: A summary of issues in the manuals and basic recommendations.**

Smith (2003: 3) suggests that “to effectively design the instructions, one must understand what happens to them when they get to consumers. For instructions to have the desired effect on consumers’ behaviour they must be successful at each point in a sequence of stages. They must capture and maintain the attention of the consumer when they are needed.” This is precisely how successful manuals need to be designed – with the outcomes of instructions being kept in view.

Furthermore, and in addition to Smith’s point, Mehlenbacher (2003: 13) adds the following considerations when designing documents:

*However, as ill-structured as documentation processes can be, developers should always attempt to develop a documentation plan that anticipates five critical dimensions of all support documentation:*

- 1. The knowledge and attributes of the intended audience.*
- 2. The task types or activities the audience will be expected to accomplish.*
- 3. The information goals that the audience will bring to the problem situation.*
- 4. The physical and rhetorical differences presented by different media.*
- 5. The genre or information type being developed.*

Apart from recommendations to the manufacturers or authors of manuals, recommendations could also be made to regulatory authorities. It would appear that the CPA is not being vigorously implemented. There needs to be greater monitoring of the quality of documentation accompanying products, whether imported or locally produced. Chirwa’s (2012: 35) study on international consumer policies documents how various countries have improved in supporting consumers, their safety and their rights. For instance, Japan’s Product Liability Act provides information on product-related incidents as well as provides the public with product safety education. The United Kingdom’s Consumer Act aims at safeguarding the consumer from products that do not reach a reasonable level of safety (2012: 38) and Australia’s Consumer Law, which is similar to the CPA of South Africa, offers basic rights to consumers, which include the right to an interpreter if English is not the consumers’ first language as well as the right to receive good quality services and to be advised if there are any limitations to these products and services (Chirwa, 2012: 40).

For this awareness to be raised, it would be important for more research studies on product manuals to be conducted. It would be recalled that product documentation is of different kinds including installation or operation manuals, quick reference guides, service manuals, instruction manuals, policy or procedure manuals and user manuals, to name a few. While the focus has traditionally been and needs to continue to be on end user manuals, it is important that other kinds of product manuals be studied as well.



## APPENDICES

### Appendix 1 – Information Sheet for Task Performance

# FACULTY OF ARTS

## Linguistics Department

### University of the Western Cape

Tel: +27 (0)21 959 3090

Email: [bantia@uwc.ac.za](mailto:bantia@uwc.ac.za)

Private Bag X17, Bellville, 7535  
South Africa

Tel: +27 (021) 959-2978/2380

Fax: +27 (021) 959-1212

Website: [www.uwc.ac.za](http://www.uwc.ac.za)

#### Information Sheet: Recorded task performance and interview with typical product owners

I, Leanne JenseL, am a postgraduate student at the University of the Western Cape, South Africa and I am currently in the process of completing my Master's degree in Linguistics. To complete my degree, I will be investigating the comprehensibility and usability of user manuals associated with two products (blenders) marketed in South Africa.

As product manuals have not frequently been the subject of academic study in the South African context, there is not much knowledge concerning the level of compliance in manuals to the provisions of product liability legislation or trade regulations (e.g. the Consumer Protection Act of South Africa, 2011). As a result of this relative neglect, it is not known how understandable users of products find these manuals or whether the claims and counter-claims in the international literature actually apply to South African product users. The idea therefore is to find out whether product manufacturers are giving sufficient attention to product documentation.

The study will include but will not be limited to the aims below:

1. To determine the extent to which typical or potential product owners can use the manuals to carry out specific tasks with the product.
2. To obtain users' views on how the semiotic resources employed in the manuals affect the readability and intelligibility of the manual.
3. To identify strategies for optimizing or improving the manuals.

The study will draw on a range of theories and methods of analysis associated with technical writing to analyse the selected manuals from the standpoint of a subset of the criteria listed in Section 22(2) of the Consumer Protection Act of South Africa. The methodology for the proposed study will combine text analysis (by the researcher) with comprehension and usability tasks performed by selected participants. Data from these sources will be collated and analysed to determine the conformity of the manuals to criteria in the CPA, and the effect the manuals have on product users.

My contact details are as follows: Ms Leanne JenseL, Department of Linguistics, University of the Western Cape, South Africa. I can be contacted at: +27 (0)21 959 2978 (Tel) or [2855127@myuwc.ac.za](mailto:2855127@myuwc.ac.za) (Email).

My supervisor is Professor Basseyy Antia, Department of Linguistics, University of the Western Cape, South Africa. He can be contacted at: +27 (0)21 959 3090 (Tel) or [bantia@myuwc.ac.za](mailto:bantia@myuwc.ac.za) (Email).

This information sheet is for you to keep so that you can be aware of the purpose of the task performance exercise. With your signature on the attached document, you indicate that you understand the purpose of the research study and task performance and interview exercise.

**Yours faithfully**

**Leanne Jense1 (2855127)**



## Appendix 2 – Information Sheet for Questionnaire

# FACULTY OF ARTS

## Linguistics Department

### University of the Western Cape

Private Bag X17, Bellville, 7535

South Africa

Tel: +27 (021) 959-2978/238

Fax: +27 (021) 959-121

Website: [www.uwc.ac.za](http://www.uwc.ac.za)

Tel: +27 (0)21 959 3090

Email: [bantia@uwc.ac.za](mailto:bantia@uwc.ac.za)

#### Information Sheet: Study questionnaire with typical product owners

I, Leanne Jense, am a postgraduate student at the University of the Western Cape, South Africa and I am currently in the process of completing my Master's degree in Linguistics. To complete my degree, I will be investigating the comprehensibility and usability of user manuals associated with two products (blenders) marketed in South Africa.

As product manuals have not frequently been the subject of academic study in the South African context, there is not much knowledge concerning the level of compliance in manuals to the provisions of product liability legislation or trade regulations (e.g. the Consumer Protection Act of South Africa, 2011). As a result of this relative neglect, it is not known how understandable users of products find these manuals or whether the claims and counter-claims in the international literature actually apply to South African product users. The idea therefore is to find out whether product manufacturers are giving sufficient attention to product documentation.

The study will include but will not be limited to the aims below:

1. To draw on theoretical concepts to evaluate the text of the manuals from the standpoint of their compliance to relevant provisions of the Consumer Protection Act.
2. To obtain users' views on how the semiotic resources employed in the manuals affect the readability and intelligibility of the manual.
3. To determine the extent to which typical or potential product owners can use the manuals to carry out specific tasks with the product.
4. To identify strategies for optimizing or improving the manuals.

The study will draw on a range of theories and methods of analysis associated with technical writing to analyse the selected manuals from the standpoint of a subset of the criteria listed in Section 22(2) of the Consumer Protection Act of South Africa. The methodology for the proposed study will combine text analysis (by the researcher) with comprehension and usability tasks performed by selected participants. Data from these sources will be collated and analysed to determine the conformity of the manuals to criteria in the CPA, and the effect the manuals have on product users. Areas for optimising (improving) the manuals will also be identified.

My contact details are as follows: Ms Leanne Jense, Department of Linguistics, University of the Western Cape, South Africa. I can be contacted at: +27 (0)21 959 2978 (Tel) or [2855127@myuwc.ac.za](mailto:2855127@myuwc.ac.za) (Email).

My supervisor is Professor Basseyy Antia, Department of Linguistics, University of the Western Cape, South Africa. He can be contacted at: +27 (0)21 959 3090 (Tel) or [bantia@myuwc.ac.za](mailto:bantia@myuwc.ac.za) (Email).

This information sheet is for you to keep so that you can be aware of the purpose of the study questionnaire. With your signature on the attached document, you indicate that you understand the purpose of the research study and questionnaire exercise.

**Yours faithfully**

**Leanne Jensei (2855127)**



## Appendix 3 – Logik Manual Questionnaire



### University of the Western Cape

#### Department of Linguistics

#### Masters Research Proposal: Questionnaire

My name is Leanne Jensel and I am completing a Masters degree in Linguistics at the University of the Western Cape. As part of the requirements for the degree, I am carrying a research study titled *A Semiotic Analysis of User Manuals for Two Blender Brands*. Your help in reading a product manual and completing the following questionnaire based on the manual is appreciated. Your responses will enable me to understand what you like and do not like about the manuals.

All answers will be processed anonymously, and it will not be possible to trace any answers back to you. Please read each statement carefully and answer each question as best as you can.

Thank you!

#### BACKGROUND INFORMATION (Tick the appropriate box)

1. What is your age?

- 19 years or younger       20 – 30 years       30 – 40 years       40 – 50 years  
 50-60 years       60 years and older

2. What is your gender?

- Male       Female

3. Which product brand are you rating?

- Logik       Ottimo

4. If you have a similar blender product, how often do you use it?

- Weekly       Monthly       Few times a year

5. If your blender product came with a manual, did you read it before using the product?

- It did not come with a manual       Saw the manual but did not read it  
 Read the manual briefly       Read the manual carefully before using the product

If you ticked the option “Saw the manual but did not read it”, what was your reason for doing so?

.....



**Please read the manual before answering the questions that follow.**

LOGIK MANUAL QUESTIONS:

---

1. Read the following passages from the manual that mention the words “stopper” and “motor housing”. Using figure 1 below as a guideline, answer the questions that follow:

-Assemble the lid and the stopper.

1. For blender, place the big jug (C) onto the motor housing with a direction the jug fit the positioning, then slightly twist it counter clockwise until it is locked.



**Figure 1**

1.1 Identify and label the part “stopper” by drawing an arrow pointed away from the image and writing the name of the part at the tip of the arrow.

1.2 Identify and label the part “motor housing” by drawing an arrow pointed away from the image and writing the name of the part at the tip of the arrow.

1.3 Was this a difficult or confusing task?

- Yes
- No

2. Study figure 2 below, which is the cover page of the Logik manual, and answer the questions that follow:

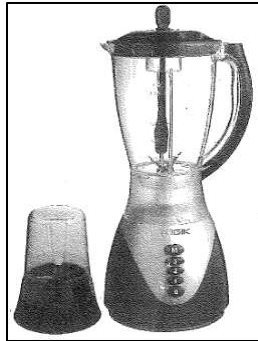

**Figure 2**

2.1 Use an arrow to show each part and write the name of the part by the tip of the arrow pointing away from the image:

-big jug

-jug

-inner cover

-motor

-switch board

2.2 Was this a difficult or confusing task?

- Yes
- No



3. Read the following passages from the manual that mentions the word “appliance” and using figure 3 below as a guideline, answer the questions that follow:

A:

Cleaning of the appliance, its parts and the accessories is easiest immediately after use.

B:

After you have processed the ingredients, you can unscrew the mill from the appliance.

C:

-Unplug the appliance

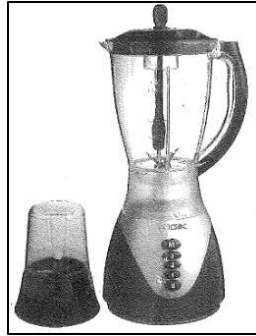

**Figure 3**

3.1 In figure 3, what does “appliance” in text A above refer to? Draw a line which you label “appliance in A” to point to the appliance referred to in the image.

3.2 Again in figure 3, what does “appliance” in text B above refer to? Draw a line which you label “appliance in B” to point to the appliance referred to in the image.

3.3 Still referring to figure 3, what does “appliance” in text C above refer to? Draw a line which you label “appliance in C” to point to the appliance referred to in the image.

3.4. Was this a difficult or confusing task?

- Yes
- No

4. Read the descriptions in figure 4 below. Now draw a line with an arrow and write 1 or 2 by the tip of the arrow pointing away from the image, showing which is the blender (1) and which is the grinder (2)?

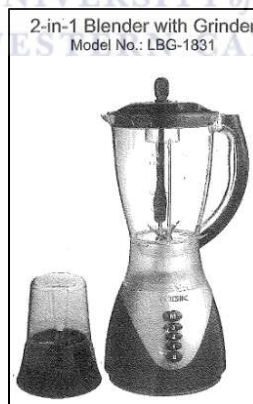
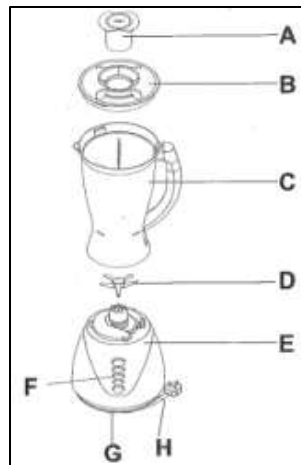

**Figure 4**

4.1. Was this a difficult or confusing task?

- Yes
- No

5. Study figure 5 below (taken from page 2 of the Logik manual), then answer the questions that follow:



**Figure 5**

5.1 Identify the switch board by writing SB close to the letter representing the switch board.

5.2 How and where did you find the answer **in the manual**? Explain:

.....

5.3 Identify the inner cover by writing IC close to the letter representing the inner cover.

5.4 How and where did you find the answer **in the manual**? Explain:

.....

6. In figure 6 below, taken from page 3 of the Logik manual, reference is made to fig. 1.

General Description (fig. 1)	
BLENDER	
A	Inner Cover
B	Lid
C	Jug
D	Blade unit
E	Switch board
F	Switches
G	Power Cord
H	Plug

**Figure 6**

6.1 Is there anywhere **in the manual** you find an image marked as fig. 1?

- Yes
- No

7. Read the following passage then answer the question that follows:

**Storage and sprinkling facilities**

After you have processed the ingredients, you can unscrew the mill from the appliance. If you remove the blade unit and replace it with the lid (fig.16), you can store the ingredients, for insurance in the refrigerator. You can also sprinkle the ingredient onto a dish via the reclosable sprinkling hole in the lid handy for on the table!

7.1 Is there anywhere **in the manual** you find an image marked as fig. 16?

- Yes
- No

8. Read the following description which mentions the words “mill”, “motor unit” and “beaker”, and using figure 7 below as a guideline, answer the questions which follow:

**Grinder**

- Unplug the appliance
- Detach the mill from the motor unit.
- Clean the beaker, the lid and the blade unit in lukewarm water

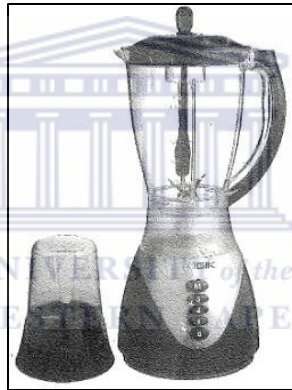

**Figure 7**

8.1 Using figure 7 above, identify the following parts by labelling them. Use a line with an arrow to show each part and write the name of the part by the tip of the arrow pointing away from the image:

- Beaker
- Motor unit
- Mill

8.2. Was this a difficult or confusing task?

- Yes
- No

8.3 Briefly explain:

.....

9. Refer to figure 8 below and answer the question that follows.

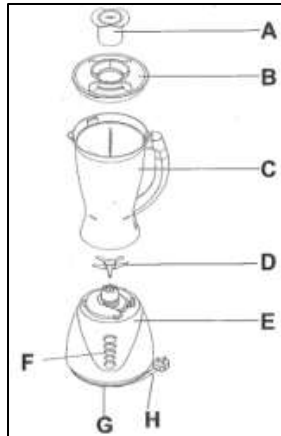

Figure 8

9.1 Are the parts of the blender clearly displayed?

- Yes
- No

10. Refer to figure 8 in the previous question, and pay attention to the part labelled D. In your view, where does the image suggest the part labelled D should be? Tick one option.

- In the part labelled E
- In the part labelled C

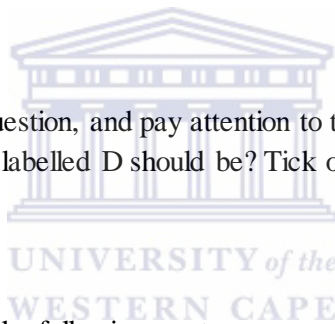

11. On page 3 of the manual, identify the following sentence:

7. To clean, follow the instruction of "Cleaning" as shown below..

11.1 Where **in the manual** is the information on "Cleaning"?

.....

11.2 If you found the above information, is it where you would have expected it to be?

- Yes
- No

12. Read the following passage from the manual and answer the question that follows:

For blender, place the big jug (C) onto the motor housing with a direction the jug fit the positioning, then slightly twist it counter clockwise until it is locked.

12.1 Do you think this instruction is clearly explained?

- Yes
- No

13. Read the passages below carefully and answer the questions that follow:

For blender, place the big jug (C) onto the motor housing with a direction the jug fit the positioning, then slightly twist it counter clockwise until it is locked.

**Storage and sprinkling facilities**

After you have processed the ingredients, you can unscrew the mill from the appliance. If you remove the blade unit and replace it with the lid (fig.16), you can store the ingredients, for instance in the refrigerator. You can also sprinkle the ingredient onto a dish via the reclosable sprinkling hole in the lid handy for on the table!

⊙ Always process cloves, star anise and aniseed together with other ingredients, if there are processed separately, they may attack the plastic parts of the grinder.

13.1 Are there things (e.g. errors, information that is not clear, etc.) you do not like in these passages?

- Yes
- No

13.2 Can your decision not to buy the blender be based on what you think of these passages?

- Yes
- No

14. Read the following tip from the manual then answer the question that follows:

For optimal blending of solid ingredients, feed a series of small amounts into the jar rather than processing a large quantity at once.

14.1 Do you think this tip is clearly explained?

- Yes
- No

**General comments about the Logik manual:**

.....

.....

**Overall opinions about the Logik product manual:**

	<b>1</b>	<b>2</b>	<b>3</b>	<b>4</b>	<b>5</b>
	<b>Strongly agree</b>	<b>Agree</b>	<b>Fairly agree</b>	<b>Disagree</b>	<b>Strongly disagree</b>
The manual's appearance and size are appropriate					
The language used in the manual is understandable and basic					
Trying to find specific information is easy					
The instructions are easy to read and understandable					
The size of the text and image are appropriate for the size manual					
The images and text blend well together					
The images are identifiable and clearly marked					
Appropriate information is given (function of the product, safety measures etc.)					

**\*\*THANK YOU\*\***



## Appendix 4 – Ottimo Manual Questionnaire



### University of the Western Cape

#### Department of Linguistics

#### Masters Research Proposal: Questionnaire

My name is Leanne Jense and I am completing a Masters degree in Linguistics at the University of the Western Cape. As part of the requirements for the degree, I am carrying a research study titled *A Semiotic Analysis of User Manuals for Two Blender Brands*. Your help in reading a product manual and completing the following questionnaire based on the manual is appreciated. Your responses will enable me to understand what you like and do not like about the manuals.

All answers will be processed anonymously, and it will not be possible to trace any answers back to you. Please read each statement carefully and answer each question as best as you can.

Thank you!

#### BACKGROUND INFORMATION (Tick the appropriate box)

1. What is your age?

- 19 years or younger       20 – 30 years       30 – 40 years       40 – 50 years  
 50-60 years       60 years and older

2. What is your gender?

- Male       Female

3. Which product brand are you rating?

- Logik       Ottimo

4. If you have a similar blender product, how often do you use it?

- Weekly       Monthly       Few times a year

5. If your blender product came with a manual, did you read it before using the product?

- It did not come with a manual       Saw the manual but did not read it  
 Read the manual briefly using       Read the manual carefully before the product

If you ticked the option “Saw the manual but did not read it”, what was your reason for doing so?

.....

**Please read the manual before answering the questions that follow.**

OTTIMO MANUAL QUESTIONS:

---

1. In figure 1 taken from page 3 of the Ottimo manual, do the following where possible:



**Figure 1**

1.1 Identify and label the part “knob” by drawing an arrow pointing away from the image and writing “knob” at the tip of the arrow.

1.2 Identify and label the part “lid” by drawing an arrow pointing away from the image and writing “lid” at the tip of the arrow.

1.3 Was this a difficult or confusing task?

- Yes
- No

2. Still, by looking at the figure above, which of the following parts can you identify? Use an arrow to show each part and write the name of the part by the tip of the arrow pointing away from the image:

-blender

-motor assembly

-blending jar

-motor

-jar

2.1 Was this a difficult or confusing task?

- Yes
- No

3. Read the following passages from the manual that mention the word “unit” and using figure 2 below as a guideline, answer the questions that follow:

A:

- Never immerse the unit in water or any other liquid for cleaning purposes.

B:

- Always operate the appliance on a smooth, even and stable surface. Do not place the unit on a hot surface.

C:

- Do not leave this appliance unattended during use. Always unplug the unit when not in use or before cleaning.

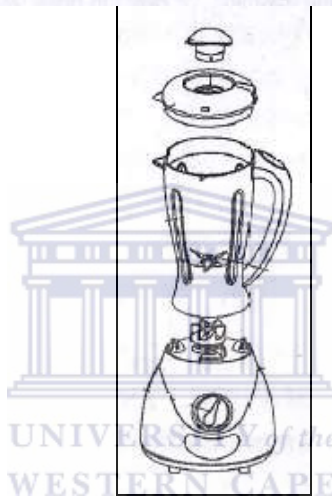

**Figure 2**

3.1 In figure 2, taken from page 2 of the Ottimo manual, what does “unit” in text A above refer to? Draw a line which you label “unit in A” to point to the unit referred to in the image above.

3.2 Again in figure 2, what does “unit” in text B above refer to? Draw a line which you label “unit in B” to point to the unit referred to in the image above.

3.3 Still referring to figure 2, what does “unit” in text C above refer to? Draw a line which you label “unit in C” to point to the unit referred to in the image.

3.4. Was this a difficult or confusing task?

- Yes
- No

4. Read the following passage from the manual and answer the question that follows:

**BLENDER ASSEMBLY INSTRUCTION:**

1. Make sure the power cord is unplugged from the power outlet and the knob is in "0" position.
2. Carefully place the Blending Jar over the Base (Motor Housing) with handle on the right hand side. Turn counter-clockwise to secure firmly into position. Make sure the "▼" marking must be pointing to the "▲" marking.
3. Place the Jar lid onto the jar.
4. Turn the Jar lid in an clockwise direction until you hear it lock into place.

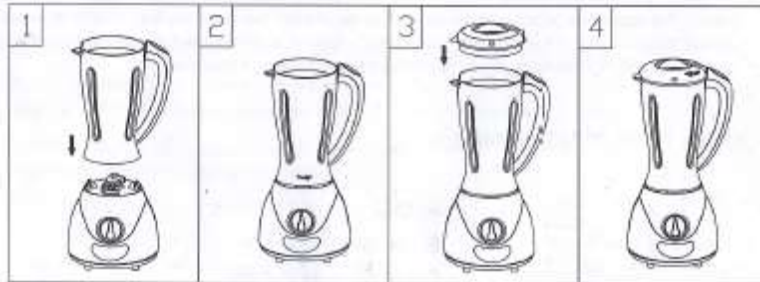

Caution: Equip the machine and make sure the triangle mark on the base sim at the triangle mark on the Blending jar, the following picture for your reference

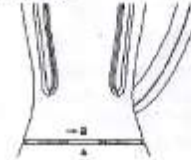

4.1 Do you think these instructions are clearly explained?

- Yes
- No

4.2 Briefly explain your answer:

.....

.....

5. Study figure 3 below (taken from page 2 of the Ottimo manual), then answer the questions that follow:

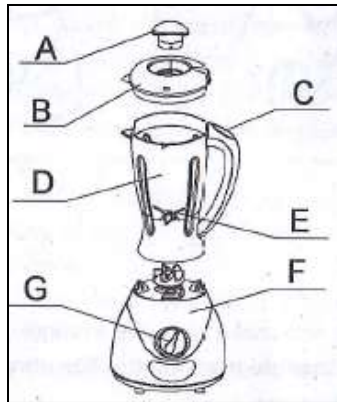

Figure 3

5.1 Identify the speed knob by writing SK close to the letter representing the speed knob.

5.2 How did you find the answer in **the manual**? Explain:

.....

.....

5.3 Identify the cap by writing CP close to the letter representing the cap.

5.4 How did you find the answer in **the manual**? Explain:

.....

.....

6. Read the following passages taken from the manual and using figure 4 below as a guideline, answer the questions that follow:

4. Don't misuse the appliance. Handle the blade with care: it is very sharp.

9. **Caution: Use extreme care when handling the Blender blade. Do not touch blades with your fingers. The Blades are very sharp and can cause injury if touched.**



Figure 4

6.1 Using figure 4 above, taken from page 2 of the Ottimo manual, identify the following parts by labelling them. Use an arrow to show each part and write the name of the part by the tip of the arrow pointing away from the image:

- Blade
- Blender blade
- Blades

6.2 Was this a difficult or confusing task?

- Yes
- No

6.3 Briefly explain:

.....

.....

7. Read the following passages taken from the Ottimo manual and answer the questions that follow:

- Always ensure that the voltage on the rating label corresponds to the voltage in your home.

**SPECIFICATIONS**

Rated voltage: AC 220-240V 50Hz  
Rated Power: 400W  
KB=1min  
Cord: 2-pin round plug

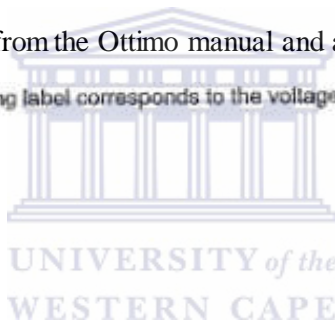

7.1 Can you explain what the manual asks you to do about the “voltage in your home”?

- Yes
- No

7.2 Do you think the specifications above are clearly explained?

- Yes
- No

8. Read the following instruction from the manual and answer the question that follows:

3. Quick cleaning method :  
Half fill the blender with warm water and a small amount of detergent. Turn to “Pulse” function and hold for 1-2 seconds and release. Repeat 3-4 times. Then remove the Jar and rinse it under running water.

8.1 Do you think the information is clearly explained?

- Yes
- No

9. Read the passages below carefully then answer the questions that follow:

2. Carefully place the Blending Jar over the Base (Motor Housing) with handle on the right hand side. Turn counter-clockwise to secure firmly into position. Make sure the "▼" marking must be pointing to the "▲" marking.

3. Wash ingredients well and cut into suitable pieces. Place ingredients into the Blending Jar (D) and replace the Jar lid (B) by turning it clockwise until you hear it lock into place. Do not exceed the maximum indicated level - 1.20 Litre.

7. Do not operated for more than 1 minute at a time, letting it rest for every other minute.

9.1 Are there things (e.g. errors, information that is not clear, etc.) you do not like in the above passages?

- Yes
- No

9.2 Can your decision not to buy the blender be based on what you think of these passages?

- Yes
- No

**General comments about the Ottimo manual:**

.....

.....

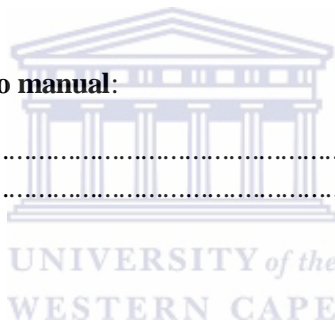

**Overall opinions about the Ottimo product manual:**

	<b>1</b> <b>Strongly agree</b>	<b>2</b> <b>Agree</b>	<b>3</b> <b>Fairly agree</b>	<b>4</b> <b>Disagree</b>	<b>5</b> <b>Strongly disagree</b>
The manual's appearance and size are appropriate					
The language used in the manual is understandable and basic					
Trying to find specific information is easy					
The instructions are easy to read and understandable					
The size of the text and image are appropriate for the size manual					
The images and text blend well together					
The images are identifiable and clearly marked					
Appropriate information is given (function of the product, safety measures etc.)					

**\*\*THANK YOU\*\***



## REFERENCES

Abushihab, I. (2010). How A Text Binds Together. *European Journal of Social Sciences*, 17(1), pp. 137-145.

Akinci, U. (2010). *3 Different Readability Indexes for your Technical Document*. Available online from: <http://www.technicalcommunicationcenter.com/2010/10/07/3-different-readability-indexes-for-your-technical-document/>. Accessed on 19 October 2012.

Antia, B.E. (2014). Language Study and the Professions. In Z. Bock & G. Mheta (Eds.), *Language, Society and Communication: An Introduction* (pp. 493-522). Pretoria: Van Schaik Publishers.

Antia, B.E. (Ed). (2007). *Indeterminacy in Terminology and LSP*. Amsterdam/Philadelphia: John Benjamins Publishing.

Antia, B.E. (2001). Terminological Investigations into Specialized Knowledge and Texts. *Terminology*, 7(1), pp. 5-29.

Antia, B.E. (2000). *Terminology and Language Planning: An Alternative Framework of Discourse and Practice*. Amsterdam/Philadelphia: John Benjamins Publishing.

Babbie, E. & Mouton, J. (2001). *The Practice of Social Research*. Cape Town: Oxford University Press.

Backinger, C.L. & Kingsley, P.A. (1993). *Write it Right. Recommendations for Developing User Instruction Manuals for Medical Devices Used in Home Health Care*. U.S. Department Of Health and Human Services.

Carlin, B.L. & Gervais, S. (2010). *Legal Protection in Retail Financial Markets*. Los Angeles. Duke University.

Carver, D.A. (1990). *Creating Effective Manuals: A Bibliographic Essay*. Library Administration & Management, pp 145-148.

*China Chamber of Commerce for Import and Export of Machinery and Electronic Products*. (2010). Available from: <http://www.cccme.org.cn/shop/cccme10366/index.aspx>. Accessed on 04 April 2012.

Chirwa, N. B. (2012). *Compliance with the Consumer Protection Act in South Africa: A case study of retail companies In Kwa-Zulu Natal*. Unpublished Masters of Commerce Thesis. Richards Bay: University of Zululand.

Creswell, J. (2007). *Qualitative Inquiry into Research Design*. 2<sup>nd</sup> Edition. California: Sage Publications.

Cowley, J.A. & Wogalter, M.S. (2011). *Reading Pages of a Consumer Product Manual Text and Warnings: Effects of Format Salience and Visual Cues on Eye Movements*. Available online from: [www.safetyhumanfactors.org/wp-content/uploads/2011/12/334Cowley-Wogalter-2011.pdf](http://www.safetyhumanfactors.org/wp-content/uploads/2011/12/334Cowley-Wogalter-2011.pdf). Accessed on 20 November 2012.

de Beaugrande, R. (1997). *New Foundations for a Science of Text and Discourse*. New Jersey: Ablex Publishing Corporation.

de Beaugrande, R. & Dressler, W. (1981). *Introduction to Text Linguistics*. London: Longman Publishers.

*Dixons Retail*. (2015). Available online from : <http://www.dixonsretail.com/dixons/en/aboutus/whoare>. Accessed on 04 April 2012.

DuBay, W.H. (2007). *Smart Language: Readers, Readability, and the Grading of Text*. Available online from: <http://www.nald.ca/library/learning/smartlang/smartlang.pdf>. Accessed on 04 April 2012.

Eiríksdóttir, E. & Catrambone, R. (2011). Procedural Instructions, Principles and Examples: How to Structure Instructions for Procedural Tasks to Enhance Performance, Learning and Transfer. *Human Factors: The Journal of the Human Factors and Ergonomics Society*, 53(6), pp 749-770.

Freeman, K. (2003). *The influence of consumer product manual warnings and on-product warnings on information retrieval and behavioural compliance*. Unpublished Master's Thesis. Department of Psychology, North Carolina State University <http://www.lib.ncsu.edu/theses/available/etd-07162003-191217/> Accessed on 04 April 2012.

Fin24.com. (2011). CPA 'plain language' poser. Available online from: <http://www.fin24.com/Economy/CPA-plain-language-poser-20111115> Accessed on 15 November 2011.

Givon, T. (1985). Iconicity, Isomorphism and Non-arbitrary Coding in Syntax. In J. Haiman (Ed), *Iconicity in Syntax* (pp. 187-220). Amsterdam/Philadelphia: John Benjamins Publishing Company.

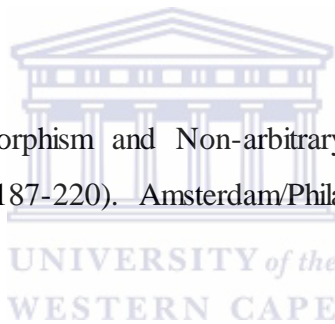

Göpferich, S. (1998). *Interkulturelles Technical Writing. Fachliches adressatengerecht vermitteln*. Tübingen: Gunter Narr.

Government Gazette (GG). (2009). *Republic of South Africa: Consumer Protection Act*. Order No. 32186, Vol. 526. Cape Town. Available from: <http://www.info.gov.za/view/DownloadFileAction?id=99961> Accessed on 27 January 2012.

Government Gazette (GC). (2012). *Economic Development Department. International Trade Administration Commission of South Africa*. No. 35007, No. R. 91. Sabinet Online. Available from: [http://www.itac.org.za/upload/gg35007\\_nn91-Import-Control-10-Feb-2012.pdf](http://www.itac.org.za/upload/gg35007_nn91-Import-Control-10-Feb-2012.pdf) and [http://www.itac.org.za/upload/gg36372\\_nn292-Import-Control-19-April-2013.pdf](http://www.itac.org.za/upload/gg36372_nn292-Import-Control-19-April-2013.pdf) Accessed on 12 March 2012.

Halliday, M.A.K. & Hasan, R. (1976/1993). *Cohesion in English*. London and New York: Longman.

Halliday, M.A.K. & Hasan, R. (1989). *Language, context and text: Aspects of language in a social-semiotic perspective*. 2nd Edition. Oxford: Oxford University Press.

Henning, E., Van Rensburg, W. & Smit, B. (2004). *Finding Your Way in Qualitative Research*. Pretoria: Van Schaik Publishers.

Rubinstein, B. (2011). *The Consumer Protection Act – A New Liability*. Available online from: <http://www.polity.org.za/print-version/the-consumer-protection-act-a-new-liability-2011-03-16>. Accessed on 08 October 2012.

Hyland, K. (2008). Genre and academic writing in the disciplines. *Language Teaching*, 41(4), pp. 543–562.

Jansen, C. & Bilijon, S. (2002). Document Design 3(3). *How do people use instruction guides? Confirming and disconfirming patterns of use*. pp 195-204. John Benjamins Publishing Co.

Johnstone, B. (2008). *Discourse Analysis*. 2<sup>nd</sup> Edition. Massachusetts: Blackwell Publishing.

Kent, D. (2006). *Writing revisable manuals. A guidebook for business and government*. Available online from: [http://www.techcommunicators.com/emanuals/wrm/chap01/01-01\\_read.htm](http://www.techcommunicators.com/emanuals/wrm/chap01/01-01_read.htm). Accessed on 20 February 2014.

Kintsch, W. & Vipond, D. (1979). *Reading comprehension and readability in educational practice and psychological theory*. In L. G. Nilsson (Ed.), *Perspectives on memory research: Essays in honor of Uppsala University's 500th Anniversary* (pp. 329-365). Hillsdale, NJ: Lawrence Erlbaum.

Kress, G. (1998). *Communication and Culture: An Introduction*. Kensington: New South Wales University Press.

Kress, G. & Van Leeuwen, T. (2001). *Multimodal Discourse. The Modes and the Media of Contemporary Communication*. London: Arnold.

Kress, G. & Van Leeuwen, T. (2006). *Reading Images: The grammar of visual design*. 2<sup>nd</sup> Edition. New York: Routledge.

Maat, H.P. & Lentz, L. (2011). Using Sorting Data to Evaluate Text Structure: An Evidence-based Proposal for Restructuring Patient Information Leaflets. *Technical Communication*, 58(3), pp. 197-216.

Maat, H.P. & Lentz, L. (2004). Functional Analysis for Document Design. *Technical Communication*, 51(3), pp. 382-398.

Mäkynen, A. (2012). *A Picture is worth a thousand words – or is it?* Unpublished master's thesis. Finland: University of Tampere, School of Language.

Manuals Online. (2015). *Samsung B1013J Washer User Manual*. Available online from: [http://laundry.manualsonline.com/manuals/mfg/samsung/b1013j\\_1.html?idRes=1619562](http://laundry.manualsonline.com/manuals/mfg/samsung/b1013j_1.html?idRes=1619562).

Accessed on 04 April 2012.

Matthews, W. (2009). *Multimodality and Negotiation of Cape Flats Identity in Selected Daily Voice Front Pages*. Unpublished Masters in Linguistics Thesis. Bellville: University of the Western Cape.

Mehlenbacher, B. (2003). Documentation: Not Yet Implemented but Coming Soon! In A. Sears & J. Jacko (Eds.), *The Human-Computer Interaction Handbook: Fundamentals, Evolving Technologies and Emerging Applications* (pp. 527-543). Mahwah, New Jersey: Lawrence Erlbaum.

Mehlenbacher, B., Wogalter, M.S., & Laughery, K.R. (2002). On the Reading of Product Owner's Manuals: Perceptions and Product Complexity. *Proceedings of the Human Factors and Ergonomics Society Annual Meeting*, 46, pp. 730-734.

Mehlenbacher, B. (2003). Not Yet Implemented but Coming Soon! In A. Sears & J. Jacko (Eds.). *The Human-Computer Interaction Handbook: Fundamentals, Evolving Technologies and Emerging Applications* (pp. 527-543). Mahwah, NJ: Lawrence Erlbaum.

Novick, D.G. & Ward, K. (2006). Why don't people read the manual? *Departmental Papers (CS)*. Paper 15. Available online from: [http://digitalcommons.utep.edu/cs\\_papers/15](http://digitalcommons.utep.edu/cs_papers/15).

Accessed on 04 April 2012.

Peter, H., Michele, H., Roshana, K., Marie, M., Heinrich, H. and Kathleen, V.D.L. (2007). *General Principles of Commercial Law*. 6th Edition. Cape Town. JUTA.

Ramaker, S. (2007). *The Genre of Technical Manuals*. Unpublished major project. Michigan: Grand Valley State University.

*Readability Formulas*. (Date Unknown). Available from: [www.readabilityformulas.com](http://www.readabilityformulas.com). Accessed on 09 January 2013.

Rogers, M. (2008). *Consistency in Terminological Choice: Holy Grail or False Prophet?* Available online from: <http://epubs.surrey.ac.uk/286645/4/Rogers%202008%20Consistency%20in%20terminological%20choice%2024June08.pdf>. Accessed on 19 October 2012.

Schäffner, C. & Wiesemann, U. (2001). *Annotated Texts for Translation: English-German: Functionalist Approaches*. Clevedon: Multilingual Matters Ltd.

Schmitz, K.D. (2007). "Indeterminacy of terms and icons in software localization." In B.E Antia (Ed), *Indeterminacy in Terminology and LSP* (pp. 49-58). Amsterdam/Philadelphia: John Benjamins Publishing Company.

Schoff, G.H. & Robinson, P.A. (1991). *Writing and Designing Manuals. 2<sup>nd</sup> Edition*. Boca Raton, Florida: Lewis Publishers Inc.

Schraver, K.A. (1997). *Dynamics in Document Design*. New York: John Wiley & Sons Inc.

Shahriar, A. & Pathan, H. (2012). Coherence and the Role of Coherent Texts. *Language in India*, 12(5), pp. 373-389.

Smith, E.A & Senter, R.J. (1967). *Automated Readability Index*. Available online from: <http://www.dtic.mil/cgi-bin/GetTRDoc?AD=AD0667273>. Accessed on 17 October 2012.

Smith, T. P. (2003). *Manufacturer's Guide to Developing Consumer Product Instructions*. Washington, DC: U. S. Consumer Product Safety Commission.

Stephens, C. (2000). *All about Readability*. Available online from: <http://plainlanguage.com/newreadability.html>. Accessed on 17 October 2012.

Standard Bank, (2011). *The Article of the Consumer Protection Act: Helping you to do good business, better*. Available from: <http://www.standardbank.co.za/site/2011/CPA/CPA-long%20version.pdf> . Accessed on 12 June 2011.

Stöckl, H. (2009). The language-image-text – Theoretical and analytical inroads into semiotic complexity. *Arbeiten aus Anglistik und Amerikanistik*, 34(2), pp. 203-226.

Struwig, F.W. & Stead, G.B. (2001). *Planning, Designing and Reporting Research*. Cape Town: Pearson Education.

South Africa (Trade and Industry Department). (2009). *Government Gazette: Consumer Protection Act of South Africa*. Available online from: <http://www.info.gov.za/view/DownloadFileAction?id=99961>. Accessed on 04 April 2012.

Stoop, P.N. (2011). Plain language and assessment of plain language. *Int. J. Private Law, Vol. 4(3)*, pp.329–341.

Sullivan, P. & Flower, L. (1986). How do users read computer manuals? Some protocol contributions to writers' knowledge. In B. T. Petersen (Ed.), *Convergences: Transactions in reading and writing* (pp. 163-178). Illinois: National Council of Teachers of English.

Terranova, G., Ferro, M., Carpeggiani, C., Recchia, V., Braga, L., Semelka, R.C. & Picano, E. (2012). Low quality and lack of clarity of current informed consent forms in cardiology. *Business and Advocacy, 5(6)*, pp. 649-655.

The Ohio Literacy Resource Centre. (2015). *Teacher to Teacher. Looking at Readability for Adult Literacy Learners*. Available online from: <http://literacy.kent.edu/Oasis/Pubs/0300-45.pdf>. Accessed on 20 April 2015.

Trading Economics. (2015). *South Africa Imports*. Available from: <http://www.tradingeconomics.com/south-africa/imports>. Accessed on 14 September 2015.

Ummelen, N. (1997). *Procedural and Declarative Information in Software Manuals. Effect on Information Use, Task Performance and Knowledge*. Amsterdam: Rodopi.

Walsh, I. (2012). *Technical Writing, Two Types*. Available online from: <http://peoplepower73.hubpages.com/hub/Technical-Writing-What-is-it#>. Accessed on 29 June 2012.

Woolever, K.R. (1999). *Writing for the technical professions*. New York: Addison Wesley Longman Inc.